



MIHÁLY KRÁMLI – AUSTRO-HUNGARIAN BATTLESHIPS AND BATTLESHIP DESIGNS 1904-1914

MIHÁLY KRÁMLI
AUSTRO-HUNGARIAN
BATTLESHIPS
AND
BATTLESHIP DESIGNS
1904-1914

Mihály Kramli

AUSTRO-HUNGARIAN BATTLESHIPS AND BATTLESHIP DESIGNS 1904-1914

MIHÁLY KRÁMLI

AUSTRO-HUNGARIAN BATTLESHIPS
AND BATTLESHIP DESIGNS
1904-1914

BELVEDERE
MERIDIONALE

Szeged, 2021

Proofreaders
Tony DiGiulian
Andrew Wilkie

Typography & Layout
György Domokos

Front Cover
Andrew Wilkie:
3D computer visualization of the S.M.S. Szent István
on her way to the Fasana Channel for gunnery practice

This book was printed with the financial support
of the Foundation for Hungarian Military Historiography

ISBN 978-615-6060-43-3 (print)
ISBN 978-615-6060-44-0 (online PDF)

© Mihály Krámlí, 2021
© Belvedere Meridionale, 2021

CONTENTS

ACKNOWLEDGEMENTS.....	7
PREFACE	9
THE IMPERIAL (AND) ROYAL NAVY	13
THE AUSTRO-HUNGARIAN – ITALIAN NAVAL ARMS RACE.....	22
THE AUSTRO-HUNGARIAN NAVAL INDUSTRY.....	29
THE ALMOST-DREADNOUGHTS OF THE DUAL MONARCHY	
THE <i>RADETZKY</i> CLASS.....	32
The Design Process	32
The Final Design.....	38
The Project of the Fourth Armored Cruiser	41
Financial and Political Background.....	42
The Construction of the <i>Radetzky</i> Class.....	44
Technical Data of the <i>Radetzky</i> Class	47
THE FIRST AND LAST DREADNOUGHTS OF THE DUAL MONARCHY	
THE <i>TEGETTHOFF</i> CLASS.....	53
The 20,000 Ton Design.....	53
The Koudelka-mission	57
Finalizing the 20,000 Ton Design	58
The Final Design.....	63
Political and Financial Background.....	66
The Construction of the <i>Tegetthoff</i> Class	71
Opinions on the <i>Tegetthoff</i> Class.....	75
THE S. M. S. <i>SZENT ISTVÁN</i>	
THE HUNGARIAN DREADNOUGHT	78
The Ganz and Co. Danubius Shipyard in Fiume	78
The <i>Schlachtschiff VII</i>	82
The Name Giving and the Launch.....	86
From the Launch to the Commissioning	88
Opinions on the <i>Szent István</i>	91
Technical data of the <i>Tegetthoff</i> class.....	93
“THE <i>MONARCH</i> CLASS MUST BE REPLACED!”	
THE “ <i>IMPROVED TEGETTHOFF</i> ” CLASS	101
The Design Process	101
The Underwater Explosion Test	108
The Final Design.....	112
Political and Financial Background.....	115
The Fate of the “ <i>Improved Tegetthoff</i> ” Class	118
Technical data of the “ <i>Improved Tegetthoff</i> ” Class.....	119

AUSTRO-HUNGARIAN BATTLESHIPS IN PEACE AND WAR	
THE SERVICE CAREER OF THE <i>RADETZKY</i> AND <i>TEGETTHOFF</i> CLASSES.....	122
La Belle Époque.....	122
The “French War”.....	124
The Eve of the “Italian War”	129
The Bombardment of Ancona	131
The Italian War: The Long Stalemate	134
The Sinking of the <i>Szent István</i>	137
The Sinking of the <i>Viribus Unitis</i>	146
End of a Sea Power.....	148
AUSTRO-HUNGARIAN HEAVY NAVAL GUNS, GUN TURRETS AND FIRE CONTROL.....	151
Austro-Hungarian Heavy Naval Guns	151
Gun Turrets.....	157
Fire Control.....	167
EPILOGUE	171
APPENDIX.....	175
Austro-Hungarian Naval Ranks in 1914 in German, Croatian, Italian and Hungarian and their Contemporary British Equivalents.....	175
Austro-Hungarian Deck Designations.....	176
Abbreviations	177
Contemporary Periodicals, Tracts and Reference Works.....	177
Endnotes	177
Bibliography	193
Source of Images	195

ACKNOWLEDGEMENTS

To the memory of my father, András Krámlí

To the memory of Dr. Peter Jung

This book, together with its Hungarian twin published in 2018 is the result of two decades of research. This project could not have been possible without the help of many people, to whom I owe my gratitude and thanks. First of all I am indebted to the late Peter Jung, Marinereferent of the Kriegssarchiv, who introduced me to the world of Marinereferent and whose assistance was vital when I began my research in Vienna on those rainy October days. I remember his remark on the yellow envelopes containing the top secret documents and that I should feel free to open them.

In 2013 I won the Géza Perjés Prize which inspired me to write the English version of my book on the Austro-Hungarian battleships. The Prize enabled me to publish this book. I am especially thankful to Éva Perjés and the curators of the *Alapítvány a magyar hadi történetírás támogatására* (Foundation for Hungarian Military Historiography) Pál Fodor, László Veszprémy, Róbert Hermann and Géza Pálffy. The financial support of the Foundation covered the expenses of the printing.

This book could not have been published without the valuable help of Tony DiGiulian from the United States and Andrew Wilkie from Canada, both of whom took on the task of proofreading the manuscript. Mr DiGiulian, who created and runs the world's leading website on naval weapons, NavWeaps.com, provided me with a range of advice and information on naval guns and ammunition. Mr. Wilkie, whose amazing website, Viribus Unitis.ca is dedicated to the battleship *Viribus Unitis* and her sisters, offered one of his fantastic 3D computer graphics of the *Szent István* for using as front cover of this book.

I am lucky to have worked with my friend and colleague, György Domokos, who took on the task of editing this book. He is the best editor I have ever worked with. I am also thankful to Gá-

bor Ferenc Kiss, Viktor Andaházi Szeghy and the whole team of Belvedere Meridionale Kiadó. I am especially proud that this book was published in my hometown, Szeged.

I would like to thank Colonel Dr. Vilmos Kovács, the commander of the Hadtörténeti Intézet és Múzeum (Institute and Museum for Military History), Budapest, Róbert Hermann, László Veszprémy, Balázs Lázár, Ferenc Bálint, Kristóf Csákváry, László Gondos, István Jándi, Kálmán Mészáros, Attila Süli, Péter Szabó, Péter András Tóth, Éva Tulipán. I am especially thankful to András Hatala, who made fantastic triple turret drawings and provided me with a range of information on explosives and projectile manufacturing. My friend and former colleague, Ferenc Pollmann shared his thoughts with me on Franz Ferdinand, the July Crisis and Dino Buzzati.

In the course of this study I have visited four archives in two countries. During the visits in these archives I have naturally benefited from the advice and assistance of a large number of individuals. I am especially grateful to the former and recent members of the Hungarian delegation in the Kriegssarchiv, Vienna: Tibor Balla, Attila Bonhardt, István Czigány, György Domokos, Gábor Kiss, Balázs Lázár, Ferenc Lenkefi, József Solymosi and Norbert Számvéber. I should like to thank Gábor Kiss in the Hadtörténelmi Levéltár, Zsuzsanna Mikó and Sándor Nyeste in the Magyar Nemzeti Levéltár. I am also indebted to my former colleagues in the Közlekedési Múzeum: László Eperjesi, Krisztina Csáki, Tamás Janovszki, Győző Jutkusz, Sándor Krizsán, László Magó and László Rózsa.

This project was only possible with international cooperation. Besides Tony DiGiulian and Andrew Wilkie, I would like to thank for their valuable help: M. Christian Ortner and Erwin

F. Sieche from Austria, Bill Jurens from Canada, Danijel Frka and Miljenko Smokvina from Croatia, Zisis Fotakis from Greece and Andrey Tammev from Russia. I am also indebted to many individuals in Hungary: György Ákos, Tamás Balogh, Ferenc Hübös, György Koltai, Péter Kovács and Dávid Turbucz. I am especially thankful to

my friend, László Kiss, who generously shared his library and photo collection with me, and with whom we had useful conversations about the fire control of battleships.

Last but not least I would like to thank the support and help provided by my family.

PREFACE

More than hundred years ago in 1918 the eighth largest navy of the world, the Austro-Hungarian Navy ceased to exist. Fifty years ago the notable naval historian Paul G. Halpern wrote these lines: “Even among historians mention of the Austro-Hungarian navy is apt to provoke smiles amid images of Ruritanian situation complete with elaborately bemedaled officers bearing grandiose titles, a bathtub fleet and in general a comic opera atmosphere.”¹ Reading this it could be easily imagined the Grand Admiral of the Fleet entering the court ball his chest fully covered with medals and ribbons towing a toy battleship on castors, while in the remote harbor a handful of sailors polish the antiquated guns of the navy’s half dozen tiny warships. Although the mention of the Austro-Hungarian Navy provokes similar images for many even today, the reality, especially in the 20th century was totally different.

Fifty years passed, and after a series of excellent books and articles written in English, German and other languages on the Austro-Hungarian Navy, the situation is nearly the same. The Navy disappeared along with the Habsburg Empire in 1918 without a successor, and the largest nations of the former Dual Monarchy (Austrians, Hungarians and Czechs) have been cut off from the sea. In these countries without real maritime traditions not surprisingly the memory of the Navy rapidly faded. While in the last two decades the history of the Austro-Hungarian Navy received growing attention, still only small groups of enthusiasts keep alive its memory in the successor states of the Monarchy. The broad public has little knowledge about the actual existence of the Navy, and the picture of a comic opera fleet is deeply rooted in the minds. The fact that the Navy in the years immediately preceding the First World War became a serious factor in the Mediterranean, and the fleet was in this period the much developed branch of the Habsburg armed forces it’s a surprise even for some historians.

In the time of my childhood in the seventies there were only a few signs in Hungary that the

Austro-Hungarian Navy actually existed. At the Museum of Military History at Budapest only the model of the battleship *Szent István* represented the Navy. Originally this model was a *Viribus Unitis* converted to *Szent István* by simply removing two from her four screws. The most popular and widespread sources of knowledge about the Navy were the fictional maritime adventure books of András Dékány written in the 1950s and 1960s. Dékány used the Navy as an interesting element of the historical background of his stories, and his picture of the Navy was incoherent and sometimes incorrect. In the Socialist regime the person of the last Flottenkommandant of the Navy, Miklós Horthy the later Regent of Hungary was also a discouraging factor for the objective research. The change began in the 1980s primarily thanks to the works of Károly Csonkaréti.

Beside the official memorabilia there were naturally some personal relics. On my father’s desk was lying a little brass anchor on a nice wooden stand with the engraving *Világháborús emlék 1914-1918* (memory from World War). Now it is in our glass-door cabinet beside my grandfather’s brass telescope and my wife’s chinaware. This anchor was bought by my great-grandmother Katica’s brother Nándor who served in Cattaro during the war. It is also a nice example of the developed Austro-Hungarian wartime souvenir industry. I saw its twin in the Serbian Orthodox Church of Szeged, a tiny silver (or silver plated brass) anchor hanging on a chain on the altar screen, the votive offering of Ferenc Pintér survivor of the *Szent István*. I saw the original relics of the former Austro-Hungarian battleships for the first time in 1991 in Venice. On either sides of the entrance of the Museo Storico Navale of Venice stands an anchor, one belonged to the battleship *Viribus Unitis* the other to the *Tegetthoff*.

The Austro-Hungarian Navy during the few years prior to the First World War transformed from a mere coastal defense force into a powerful war machine and a Mediterranean power, thanks to its new *true* battleships. These battleships, the

mixed-caliber battleships of the *Radetzky* class, the dreadnoughts of the *Tegetthoff* class and the projected dreadnoughts of the “*Improved Tegetthoff*” class often called the *Ersatz Monarch* class made the Austro-Hungarian Monarchy a sea power and an important factor in the Mediterranean. The history of the design process of these battleships is more important and interesting than at the first look it may seem, because aside the technical information it perfectly reflects the changing naval policy of Austria-Hungary.

If we accept the theory that the historian’s text is a literary artifact, this book is a novel, a novel of building a cathedral. The topic of this novel is the building of the steel cathedral of Austro-Hungarian sea power, the Empire’s battleship fleet. In that time during the great naval arms race preceding the First World War the cathedrals of sea power were the battleship fleets, which were in addition very important attributes of great power status. The Austro-Hungarian cathedral suffered a sad fate after 1918: it was demolished, its carvings were destroyed and its stones were carried away and on its former site grow now only weeds and oblivion.

This work is based upon the unpublished documents found in the Kriegsarchiv in Vienna in the first place. Documents related to the design process of the battleships are either in the files of the Präsidialkanzlei and of the II Geschäftsgruppe of the Marinesektion. The documents of political and financial questions are exclusively in the files of the former, while the documents of the battleship construction are exclusively in the files of the latter. The second most important source of documents is the Mladiáta-collection in the Magyar Műszaki és Közlekedési Múzeum Archivuma (Archives of the Hungarian Technical and Transport Museum) in Budapest. János Mladiáta served as a naval architect (Schiffbauingenieur) in the Austro-Hungarian Navy between 1903 and 1918. He had later an important role in reorganizing the Hungarian Danube Flotilla. He was an avid collector and during his long career collected thousands of plans and documents. His collection contains important documents on the battleship design and on naval guns and gun turrets. Mladiáta preserved such documents which are today missing from the files of the Kriegsarchiv. A notable example is the protocol of the underwater explosion test to evaluate the torpedo protection system of the 24,500 ton

battleships in 1914. There are important documents on the wartime career of the battleships in the Hadtörténelmi Levéltár (Archives of Military History) in Budapest. These are official copies of original files of the Kriegsarchiv made in the early 1920s on the initiative of Károly Lucich, who commanded the Donauflottille in 1914-1917. The Magyar Nemzeti Levéltár Országos Levéltára (Hungarian National Archives) contains a few documents on the Danubius shipyard and the battleship *Szent István*. Unfortunately, the majority of the documents fall victim of culling in the 1950s. In the files of the National Archives of the United States there are two American reports on the fire control of the Austro-Hungarian battleships which are the most valuable sources of the fire control system.

Battleships and their history were always popular topics, the Austro-Hungarian ones are no exceptions, especially the dreadnoughts of the *Tegetthoff* class. Thanks to this popularity many articles and other works were published over the last hundred years on them. By the very nature of the things the majority of these works are popular and semi-scholarly and there are only a few works based on extensive archival research. Of them all, stands out Christoph Ramoser’s excellent book *K. u. k. Schlachtschiffe in der Adria* on the *Tegetthoff* class. Friedrich Prasky’s book *Die Tegetthoff-Klasse* and the articles of Erwin F. Sieche provide also valuable information on the Austro-Hungarian battleships and battleship designs. Among more general works on the history of the Austro-Hungarian Navy the most important are Paul G. Halpern’s two books, *The Mediterranean Naval Situation, 1908-1914* and *Anton Haus, Österreich-Ungarns Großadmiral* and Lawrence Sondhaus’s *The Naval Policy of Austria-Hungary, 1867-1918*. Very helpful are Walter Wagner’s *Die obersten Behörden der k. u. k. Kriegsmarine, 1856-1918* and Antonio Schmidt-Brentano’s three volume *Die österreichischen Admirale, 1808-1924*. The first is a detailed study of the history of the naval administration, the latter is an abundant source of information on all the Austrian and Austro-Hungarian admirals. Of the handful unpublished Austrian dissertations the most useful are Leo Reiter’s *Die Entwicklung der k. u. k. Flotte und die Delegationen des Reichsrates* and Erich Krenslehner’s *Die k. u. k. Kriegsmarine als wirtschaftliche Faktor, 1874-1914*. Reiter deals with the Navy’s budget battles in the Aus-

trian Delegation, Krenslöhner provides an account of the close link between the economy and the naval expansion. The latter is the topic of the unpublished American dissertation written by Louis A. Gebhardt Jr. *The Development of the Austro-Hungarian Navy 1897-1914. A Study in the Operation of Dualism.*

Despite the Kingdom of Hungary being a part of the Dual Monarchy, the last wartime Flottenkommandant of the Navy was the Hungarian Miklós Horthy, the Hungarian historiography has not shown much interest for the history of the Austro-Hungarian Navy. It was true also for the 1920s and the 1930s when the political climate was favorable for such researches. The most important work which was published in this period was Olaf Wulff's semi-official history of the Donauflotte in the World War. After 1945, especially after 1948 the new regime viewed Horthy as a "supervillain" and the history of the Navy became a taboo for three decades. Károly Csonkaréti, an amateur historian began to publish semi-scholar and popular books and articles on the Austro-Hungarian Navy in the 1980s. His works played an important role in catching the attention of the Hungarian public and in encouraging others to research the history of the Empire's navy. In the early 2000s there appeared a new generation of scholars and amateur researchers. Among their works are the most important Tamás Balogh's and Oszkár Csepregi's *A Szent István csatahajó és a csatahajók története* and András Margitay-Becht's *A Leitha monitor ...és a többiek.* The first of these richly illustrated books deals with the history of the battleship *Szent István* and with the Hungarian diving expeditions to her wreck. The latter deals with the history of one of the first pair of Austro-Hungarian river monitors, the *Leitha* which today serves as a museum ship in Budapest. I have to mention also my book *A császári és királyi haditengerészet és Magyarország,* which deals with the pro-navy turn of the Hungarian political elite and the development of the Hungarian naval industry prior the World War I.

This book is a somewhat shortened and re-worked English version of my book published in 2018 on the last Austro-Hungarian battleship classes *Az Osztrák-Magyar Monarchia csatahajói 1904-1914.* I have omitted some chapters of the Hungarian book which were written specially for the Hungarian public not well-informed on naval matters. On the other hand this English version incorporates the results of my researches made since the publication of the Hungarian version. Most of these new additions are found in the chapters on the wartime career of the battleships and on their armament.

Finally, some notes on geographical names, ranks and units. Being a book on a historical topic I prefer to use the pre-1918 official geographical names with some exemptions (like Vienna, Rome, etc.). It is more convenient as these versions of geographical names are found in the contemporary official documents. It is true that many of these names were changed during the past hundred years some of them not only once, today in the age of internet and smartphones it can be found the new names within seconds. In the case of the naval ranks, especially of the Austro-Hungarians I chose to follow the method of some notable American naval historians to use the original form of these ranks (in German). At the end of the book a summary of the Austro-Hungarian naval ranks can be found in the appendix. A summary of the Austro-Hungarian deck designations can also be found in the appendix. As the Austro-Hungarian Monarchy adopted the metric system, the Empire's Navy used the metric units with some notable exemptions like nautical mile or knot. In this book I use the units that the Navy used, for example, "tons" as used by the Navy were metric tons (1,000 kg). One of the most important data of the battleships, normal displacement (Konstruktions-Wasserdrangung), in the Austro-Hungarian Navy was calculated with 50% fuel, 50% ammunition and 50% reserve feedwater which differed from the methods used by other sea powers.

THE IMPERIAL (AND) ROYAL NAVY

As a land power in the first place, the Habsburg Empire had no permanent navy before the end of the eighteenth century. The predecessor of the Navy was established in Trieste in 1786 by Emperor Joseph II. When Austria took possession of Venice, Dalmatia and Istria in 1797, on the basis of the former Venetian Navy was established the Imperial-Royal Navy (kaiserlich-königlich Kriegsmarine). Its name was changed to Imperial and Royal Navy (kaiserlich und königlich Kriegsmarine, császári és királyi haditengerészet) in 1889. The Habsburg rulers and the state bureaucracy traditionally had little interest in or understanding of the significance of sea power for the Empire. This was one of the main reasons for the slow development and the underfinanced state of the Austrian (after the Compromise between Austria and Hungary of 1867 Austro-Hungarian) Navy during the nineteenth century. In the greatest part of its history, the Navy was the “stepson” of the Habsburg armed forces, no more than a mere coastal defense force.

In the history of the Austro-Hungarian Navy there were two great periods of development. The first period began in 1850, after the shock of the Revolution of 1848. The tempo of the development accelerated under the command of Archduke Ferdinand Max (1854-1864), younger brother of Franz Joseph, the ill-fated later Emperor of Mexico (1864-1867). This period culminated in an ironclad naval arms race with the eternal rival Italy and in the victory over the Italian fleet at Lissa in 1866. After the death of Wilhelm von Tegetthoff in 1871, the greatest Austro-Hungarian naval hero, the victor of Lissa, who was the commander of the Navy from 1868, it began a long period of stagnation and frustration again.

After more than two decades of stagnation the new period of development began in the 1890s. External and internal factors as well played significant role in the development of the Austro-Hungarian Navy in this period. In the age of navalism the sea power became more and more important and even a land power, the Austro-Hungarian Monarchy had to follow the international trend. It

was an important factor too, that the formal ally of the Dual Monarchy the eternal rival Italy, after its defeat at Adua (1896) turned to the eastern Adriatic again, with the claim of unify the Italians living in the Austro-Hungarian Monarchy with the kinsman in the Kingdom of Italy. The Russo-Japanese war intensified the Austro-Hungarian fears of an Italian assault on the Adriatic coastline. The domestic factors also helped the development of the Austro-Hungarian Navy. The emerging new political parties in Austria had a pro-navy sentiment and thanks to the growing domestic industrial orders the representatives of the heavy industry became friends of the Navy. And one of the most important things: the new heir of the throne Archduke Franz Ferdinand became the patron of the Navy. The intensive development began in 1904. The budget of the navy increased nearly by 400 percent between 1904 and 1914, while the Navy's quota in the defense budget grew from 7 to 25 percent. This period culminated in a dreadnought naval arms race with Italy.

Austria took possession its first territory on the Adriatic coast, the city of Trieste in 1382. The Kingdom of Hungary after seizing the Croatian throne reached the Adriatic in 1102. In 1526, after the catastrophic Hungarian defeat by the Turks at the Battle of Mohács the Austrian Habsburgs seized the Hungarian and the Croatian thrones, and the two countries became parts of the Habsburg Empire. In the period of the long wars with the Turks, who possessed the central part of Hungary, the Habsburg rulers were less interested in maritime affairs. They began to show some interest to the sea power only in the 18th century. Two short lived initiatives to establish a navy took place under Emperor Karl VI and later under Empress Maria Theresia, but until the end of this century Venice dominated almost the entire eastern coastline of the Adriatic. The permanent navy, with two small ships was finally established in 1786 in Trieste. In 1797 Venice, the “queen of the seas” was conquered by Napoleon, who deliv-

ered the city with all its possessions to Austria in the Treaty of Campo Formio. On the basis of the former Venetian Navy was established the Imperial-Royal Navy. Until 1848 the majority of the officer corps was Venetian, and the service speech of the Navy was Italian.

The revolutions of 1848 shook the foundations of the Navy; grave problems emerged with the loyalty of the officer corps and also with the material state of the fleet. Great reforms had begun in 1850 under the leased Danish Vizeadmiral Hans Birch von Dahlerup (1849-1851). The two main aims were to Germanize the Navy, especially the officer corps and to catch up in material strength the combined fleet of the Italian states. In 1850, German had replaced Italian as the service speech, the Marineakademie was moved from Venice to Trieste and the officers who were not able to learn in German were expelled. The Flottengesetz (Navy Law) of 1850 ordered to build six sailing ships of the line along a few dozens of other smaller ships, a great step forward, because this type of ship the Navy never had had before. Despite the Flottengesetz only one ship of the line was actually built, but as a screw steamer. In 1854, the younger brother of Franz Joseph, Archduke Ferdinand Max held the post of Marinekommandant (Commander of the Navy) (1854-1864). The talented and energetic young archduke with his brother behind his back successfully accelerated until then slow development the Navy. His first great success came in 1857 when he succeeded to create a separate budget for the Navy, which was no more part of the Army's budget. This budget almost quadrupled in the next few years.

After the catastrophic war of 1859, Archduke Ferdinand Max doubled his efforts to modernize and to strengthen the Navy. Ironically his major ally in this struggle was the threatening naval superiority of the newly created Kingdom of Italy. With the advent of the ironclads an ironclad naval arms race evolved from 1861 between Austria and Italy. Under Archduke Ferdinand Max seven Austrian ironclads were built, while the Italians built or purchased twelve. In 1862 a separate Marineministerium (Ministry of Marine) was established. Soon after the departure of the archduke for his short and ill-fated career as Emperor Maximilian of Mexico, the Marineministerium was dissolved. The short-lived independence of the Navy end-

ed for all, it came under the administration of the Marinesektion of the Kriegsministerium (Ministry of War). The post of the Marinekommandant was vacant until 1868.

Fortunately for the Navy Archduke Ferdinand Max had a great successor, a rising star who was accepted as an unofficial leader of the Navy: Wilhelm von Tegetthoff. During the war with Denmark in 1864 he distinguished himself as the commander of the small Austrian squadron in the Battle of Heligoland, and was promptly promoted to Kontreadmiral by Franz Joseph. In the war with Italy in 1866 he commanded the inferior Austrian fleet against the Italian fleet in the Battle of Lissa and achieved the greatest victory in the history of the Austrian Navy. Franz Joseph promoted him to Vizeadmiral but contrary all expectations the post of Marinekommandant still remained vacant. Finally, a Habsburg familiar tragedy helped Tegetthoff to the post of Marinekommandant. Tegetthoff led the Austrian delegation which successfully negotiated in Mexico about bringing home the mortal remains of the executed Emperor Maximilian. The deeply touched Franz Joseph after this diplomatic success finally appointed Tegetthoff to Marinekommandant in 1868.

Between the war of 1866 and the appointment of Tegetthoff, something of immense importance happened: The Compromise (Ausgleich, kiegyezés) of 1867. The Habsburg Empire became Dual Monarchy two separate and equal states each possessing its own constitution, parliament and government. The two halves of the Empire, Austria and Hungary were tied together in the person of the Emperor (Emperor of Austria and Apostolic King of Hungary) and by the system of common affairs as foreign affairs, war and the finance of them. Three so called common ministries were established: Ministry of Foreign Affairs, common Ministry of War and common Ministry of Finance, all in Vienna. Both states had their own separate ministries of finance and ministries of war, the latter with minor importance. The legislative power of the Austrian Reichsrat and the Hungarian Parliament (Országgyűlés) over the common ministries was exercised by the delegations (Delegation des Reichsrates in Austria, az Országgyűlés közösügyi bizottsága in Hungary), two sixty-member bodies elected by each of the parliaments. To demonstrate their absolute equality they met alternately in Vienna and



1 *The Battle of Lissa 20 July 1866*

Budapest. They sat separately, and the budget proposals of the common ministries were laid before both at the same time by the common ministers. In fact the meetings of the delegations were the place of political show and circus rather than real decisions. Real decisions were made on the common Council of Ministers (*gemeinsamer Ministerrat*), the informal common government of the Empire.² The question of which proportion of the common expenses each half of the Monarchy would bear, the so-called Quota had to be negotiated every ten years. The Hungarian contribution (Quota) was originally 30 percent, which rose gradually and in 1907 reached 36.4 percent.

The greatest part, more than 90 percent of the common expenses was the budget of the common Army and the Navy. The armed forces of the Dual Monarchy had three levels. The most important were the common Army and the Navy. On the second level there were the militias of both states, with their own ministries: the *k. k. Landwehr* in Austria and the *m. kir. Honvédség* in Hungary. On the third level were the *Landsturm* in Austria

and the *Népfelkelés* in Hungary, which were wartime third class militias. The title of the common institutions before 1889 was *k. k. or cs. kir. (kaiserlich-königlich, császári-királyi)*. The Hungarians were keen to be seen as absolute equals in the Dual Monarchy, so after a long struggle Prime Minister Kálmán Tisza succeeded in 1889 to change the title of common institutions to imperial and royal (*k. u. k., cs. és kir., kaiserlich und königlich, császári és királyi*). The naval ensign, however, remained the old red-white-red flag with the Austrian crown as remained the German service speech. In 1915, Franz Joseph authorized the new naval ensign, which was half Austrian and half red-white-green Hungarian with both crowns. The introduction of the new flag was postponed until the end of war.

Tegetthoff, as newly appointed *Marinekommandant* made a proposal for the administration and organization of the Navy. He knew that Franz Joseph would not agree with the idea of the independent Navy, so he proposed a subordinated but autonomous Navy for the Emperor. Franz Joseph was content with his proposal and appointed him



2 Viceadmiral Wilhelm von Tegetthoff

to Chef der Marinesektion too. From Tegetthoff until 1917 all the Marinekommandants were appointed automatically as Chef der Marinesktion. In this administrative system the war minister was responsible for the navy to the delegations.³ As the budget and the importance of the Navy grew around the turn of the century, its unequal and subordinate position became more and more disadvantageous. Marinekommandant Herman von Spaun launched a plan to establish an Admiralty in 1900, but Franz Joseph rejected it. The Heir of the Throne Archduke Franz Ferdinand planned to create a separate Ministry of Navy after coming to the throne, despite the fears that, with four common ministries the Hungarians might demand to transfer some of them to Budapest. The assassination of Franz Ferdinand hindered the establishment of the new ministry, and the system laid down by Tegetthoff remained in use until the very end of the Dual Monarchy.

As the Dual Monarchy itself, the Imperial and Royal Navy was a multiethnic and polyglot force. Naturally, especially in the first decades the bulk of the crews came from areas adjacent to the Adriatic. Croats (mostly from Dalmatia⁴) formed the largest national group they were followed by Italians, Germans and in minor numbers of oth-

er nationalities. In 1887 46 percent of the crews were Croats and 33 percent were Italians.⁵ Afterwards, the Army Service Law of 1889 had begun to increase the number of the Hungarians among the recruits. While the number of the Italians decreased, immediately before the war Hungarians constituted the second largest group of the personnel behind the Croats. In 1913, 31 percent of the crews were Croats, 20 percent were Hungarians, 17 percent were Germans and 14 percent were Italians.⁶ The number of the crews on active service rose from 7,000 to 14,000 between 1887 and 1913. Among the crews was some unofficial specialization: Croats and Italians mostly worked on deck, Germans and Czechs tended to the mechanical and electrical services, while Hungarians served mainly as gunners. The petty officer corps was dominated by Germans and Czechs.

The officer corps was dominated by Germans, their representation was a steady 50-55 percent throughout the decades of the Dual Monarchy. In 1910, the 897 officer corps constituted of 51 percent Germans, 13 percent Hungarians, 10 percent Italians, 10 percent Croats, 9 percent Czechs and in minor numbers other nationalities.⁷ The majority of the officer corps were graduates of the k. u. k. Marineakademie (naval academy) at Fiume. Entry in the officer corps was also possible by a two-year course after graduation in a Gymnasium (grammar school). The Hungarian government provided easier access for Hungarian candidates to the Marineakademie, but the majority of Hungarian officers soon left the naval service for a better career in the Honvédség.⁸ The most famous exemption was Miklós Horthy, the only active Hungarian admiral after 1867. The officer corps of the Austro-Hungarian Navy considered itself a small but elite group. The Navy also seemed relatively immune from the nationalism which plagued the multinational Dual Monarchy, and it was not until the end of the World War I that serious incidents occurred.

The Navy until the first decade of the 20th century received scant support from the court. Contrary to his late younger brother, Emperor Franz Joseph regarded the Habsburg Empire as primarily a continental power and took little interest in naval or maritime affairs. Personally he disliked sea voyages because he gravely suffered from nausea. He seldom inspected his Navy, the last time in 1907. Archduke Franz Ferdinand was the direct oppo-

site of his uncle in regard to naval affairs. In 1892-1893 he had been on a world cruise on the cruiser *Kaiserin Elisabeth*, and the Navy deeply impressed him. In 1902 he had given the rank of Admiral. He admired the German Kaiser Wilhelm II who was a great naval enthusiast. Franz Ferdinand was probably the most influential and energetic patron of the Navy, although there were times when the Heir of the Throne's intervention into naval affairs caused headaches to the leaders of the naval administration.

After his appointment Tegetthoff made great efforts to modernize and strengthen the fleet. In September 1868, he presented his ten year program, which proposed a fleet of fifteen armored ships and thirty-four frigates and corvettes. In 1869, the delegations voted for two armored casemate ships and for rebuilding the ship of the line *Kaiser* into casemate ship. The cost of the whole program would have been 25.3 million Guldens (50.6 Kronen)⁹, but it was never officially accepted. The last success of Tegetthoff was securing a record high, 11 million Guldens budget for 1871. The seriously ill Marinekommandant died in April 1871 at age of 43. With the death of Tegetthoff the Navy lost its greatest hero and a charismatic leader.

After the death of Tegetthoff, Baron Friedrich von Pöck, protégé of Archduke Leopold and the great rival of Tegetthoff,¹⁰ was appointed to Marinekommandant. Pöck was ill-fitted in every sense to the post of Marinekommandant, and a long period of stagnation and frustration began for the Navy. His only success in the field of armored ships was the casemate ship *Tegetthoff* voted in 1875. Pöck's incompetence, bad relations with the Emperor and with politicians combined with the economic crisis of 1873 sealed the fate of Tegetthoff's program. In 1878, the Navy had nine armored ships in active service and one under construction instead of the proposed fifteen. Max von Sterneck, friend of Tegetthoff, the future Marinekommandant wrote in a letter in 1878: "this is no more stagnation, this is retrogression."¹¹

In 1880, when the first great turret ship of the Italian navy entered in service a little panic broke out in Vienna. A board, mostly constituting of army generals, headed by Archduke Albrecht was convoked to decide for the future development of the fleet. Pöck proposed a fleet of sixteen armored ships and ten cruisers for 1888. In Archduke Al-



3 Archduke Franz Ferdinand, the Heir of the Throne

brecht esteem, there was no need of great expenditures on armored ships, instead of them the cheap devices of a "defensive little war" (torpedoes, mines) had to be developed. The majority of the board members voted along with the archduke.¹² In these years, the Austro-Hungarian Navy was among the leaders in the development and use of the new weapon, the torpedo. The automotive torpedo was also an Austrian invention, and Whitehead in Fiume was the first torpedo factory of the world.

The Triple Alliance with Italy in 1882 was a real catastrophe for Pöck: the Austro-Hungarian Navy lost its strongest argument for developing, the Italian menace. Pöck had a nervous breakdown in 1883, and the Emperor appointed his rival, Max von Sterneck to Marinekommandant. With Sterneck, a hero of Lissa held the post of Marinekommandant again; he had been the captain of Tegetthoff's flagship in the battle. He made some minor changes in the administration of the Navy, the most important was the establishment of the Operationskanzlei in 1885, which worked as a naval general staff, and he established the Marinetechnische Komitee (naval technical board). In 1884, after nearly a decade long interval works be-



4 Admiral Hermann Freiherr von Spaun

gan on two new armored ships. These were the first turret ships, and the first ships armed with 30.5 cm guns of the Austro-Hungarian Navy.

In his first years Sterneck sympathized with the French “*Jeune École*” (Young School),¹³ so until 1892 many smaller vessels were built, along with five unarmored cruisers. In the summer of 1891, Sterneck presented his fleet program of nine battleships, six large and twelve small unarmored cruisers, twelve destroyers and seventy-two torpedo boats to the Emperor. This proposal was visibly inspired by the concept of “*Jeune École*”.¹⁴ Sterneck’s program failed, because it was not supported by the Emperor, by the Army, and even by the officer corps of the Navy.¹⁵

After the fiasco of his program, while on the surface he was repeating the slogans of the “*Jeune École*”, Sterneck was converted to the cause of armored ships. The 1890s brought important changes. The change of the naval strategy and tactics coincided with the changes in the world policy and with the transformation of the alliance system, and also with the internal political and economic changes of the Dual Monarchy. The emerging new parties in Austria had much more sympathy towards the Navy than the deliberately anti-navy old liberals, and the

leaders of the rapidly developing Austrian heavy industry realized what lucrative possibilities inhered in the development of the fleet. The first sign of the changing of Sterneck’s views was the conversion of the projected third large unarmored cruiser to armored cruiser. In 1893, the delegations voted for the yearly increase of the Navy’s budget with one million Kronen. This rendered possible the building of the three units of the *Monarch* class coastal defense ships. These ships were miniature versions of the standard battleships of the time, armed with 24 cm guns instead of 30.5 cm ones. With this class a new era began in the Austro-Hungarian Navy, from this date in almost every year a new armored ship was launched in the Dual Monarchy which was in marked contrast to the 1870s and 1880s.

In December 1897, Sterneck died unexpectedly. His deputy, Admiral Hermann von Spaun was appointed to Marinekommandt. The construction of armored ships was Spaun’s priority, and subordinated almost everything to this.¹⁶ In the spring of 1898, the new Marinekommandant presented his program of twelve battleships, twelve cruisers, twelve destroyers and seventy-two torpedo boats to the Emperor and to the politicians. A special credit of 110 million Kronen would have covered the expenses of that program.¹⁷ Unfortunately for Spaun, his program coincided with Tirpitz’s first Navy Law, and with the Spanish offering of one of their African colony (Rio Oro) to the Dual Monarchy. The contemporaries considered Tirpitz first law as the sign of the greater German colonial activity, so the consistently anti-colonialist Hungarian government looked at Spaun’s program what served Austrian colonial aims. On the common Council of Ministers the Hungarian Prime Minister Dezső Bánffy torpedoed the special credit, but the Hungarian delegation voted for the new 8200 ton battleships (*Habsburg* class) and for a modest yearly increase of the Navy’s budget.¹⁸ After his fiasco Spaun recognized that his long-term development projects cannot be realized without the support of the Hungarians, so he began to pursue new, pro-Hungarian politics. The second ship of the new battleship class was named *Árpád*.¹⁹ In August 1898, Spaun made a written promise that the Hungarian industry’s share in the Navy’s orders will be in proportion to the quota in the future.²⁰

In the summer of 1900, when his relationships with the common War Minister Edmund Krieg-

hammer deteriorated, Spaun tried to reorganize the Navy's administration. Spaun planned to establish an Admiralty instead of the Marinesektion, which would have been subordinated to the common Ministry of War too, but its chef would have wider competence, and could have negotiate directly with other ministers. The Emperor rejected Spaun's plan and all remained the same. After the failure of his reform initiative Spaun concentrated on armored ships. The delegations voted for an armored cruiser in 1900 (*Sankt Georg*) and for a new, 10,600 ton battleship class in 1901 (*Erzherzog Karl* class).

The year of 1904 was a landmark in the history of the Austro-Hungarian Navy. In this year the delegations voted for the first extraordinary credit²¹ for the Navy. This 120 million Kronen extraordinary credit made possible the long waited and needed modernization of the torpedo-flotilla which was neglected from 1898. The Austro-Hungarian fears of an Italian surprise attack on Pola, while Italy was a formal ally, similar to the Japanese attack on Port Arthur facilitated the voting of this credit. In that year was founded the Österreichisches Flottenverein (Austrian Navy League) with thirty-nine members. Ten years later the Flottenverein, which was backed by Archduke Franz Ferdinand, had 44,617 members. The Flottenverein's monthly organ, *Die Flagge* advocated for developing both the Navy and the Austrian merchant fleet.

The Austrian Finance Minister insisted that the Navy had to repay the credit from its ordinary budget. To protest against this decision, in October 1904 Spaun resigned. Fortunately for the Navy later the delegations cancelled this repayment obligation. Beside the extraordinary credit of 1904 the greatest success of Spaun was the fact, that in his years in office the proportion of the Navy's share of the armed forces' total budget rose from 7.5 percent to 11.7 percent.

In October 1904, the Emperor appointed Admiral Rudolf von Montecuccoli to Marinekommandant. Montecuccoli was the last Marinekommandant who was a veteran of the Battle of Lissa. Montecuccoli inherited a more modern fleet that Spaun seven years ago, but Italy's superiority was still overwhelming. The diplomatically talented Montecuccoli was the man, who made the Austro-Hungarian Navy – backed by the growing support of the Heir of the Throne, the Austrian parties and industrialists – from a coastal defense force to



5 Admiral Rudolf Graf von Montecuccoli degli Erri

a Mediterranean factor. In the summer of 1905, he presented his first fleet program of thirteen battleships, twelve cruisers, eighteen destroyers, eighty-two torpedo boats and six submarines.²² In 1906, Montecuccoli prepared a memorandum on the necessity of strengthening the fleet through accelerating the replacement of obsolete vessels. The main purpose of this memorandum was to pave the way for the new battleship class, the first true battleships of the Austro-Hungarian Navy. At the end of 1906, the delegations finally voted for these 14,500 ton battleships with mixed 30.5 cm and 24 cm main battery (*Radetzky* class).

In July 1906, in a speech before the Austrian delegation, Montecuccoli stated that in the future the Austro-Hungarian Navy should build 20,000 ton battleships to follow the international trends.²³ After the dreadnought-revolution it was a logical step to shift to the construction of true dreadnoughts. The most important task of Montecuccoli was in the next few years to secure the funds for the construction of the first Austro-Hungarian



6 Admiral Anton Haus

dreadnought class. The Bosnian crisis of 1908 with its threat of war was favorable for additional expenditure on armaments. Referring to the Italian threat of war Montecuccoli presented in 1908 his second fleet program of sixteen battleships, twelve cruisers, twenty-four destroyers, seventy-two torpedo boats and twelve submarines. This program included four 20,000 ton dreadnoughts.²⁴ After forty years this was the first fleet program which exceeded the aims of Tegetthoff's program of 1868.

The design process of the new battleships began in 1908. Italy laid down its first dreadnought in 1909. As early as 1908 it was evident, that the expenses of the new construction program, consisting four dreadnoughts, three turbine powered cruisers (scouts), six modern destroyers, twelve torpedo boats and six modern submarines, could be covered only with an extraordinary credit. The Heir of the Throne, Franz Ferdinand on several occasion urged the Navy in 1909 to begin the

construction of the new battleships, but the 1909 political crisis in Hungary made it impossible to meet the delegations and vote for the extraordinary credit. Thus, after an agreement with the Austrian Rothschilds on financial backgrounds, the Navy backed by Franz Ferdinand made an "unconstitutional" step in November 1909, before voting the expenses, ordered in a secret contract two dreadnoughts from the STT, formally "at the own risk" of the shipyard. The Navy promised to take over the ships when the delegations finally would vote the credit. The two dreadnoughts were laid down in 1910 in Trieste. In early 1911, the Delegations finally voted the extraordinary credit of 312 million Kronen. The Hungarian votes had their price: one third of the industrial orders went to the Hungarian industry, and one of the four dreadnoughts was ordered in the Hungarian Danubius shipyard.

The securing of the first dreadnought class was the last success of Montecuccoli. Montecuccoli's independent contracting of debts with the yards and banks led to a sharp disagreement between himself and the War minister in March 1912. Franz Ferdinand's intervention prevented the scandal, but the Heir of the Throne decided to separate the administration of the Navy and the actual commandership. In the summer of 1912, a new post was created, the Flotteninspektor (surveyor of the fleet), which naturally weakened the position of the Marinekommandant. The Flotteninspektor's task was to assume the active command of the fleet in the case of a war. Vizeadmiral Anton Haus was appointed to Flotteninspektor. In the course of 1912 Montecuccoli on a few occasions tried to present a proposal for a second dreadnought class, but it was too early, considering the financial state of the Dual Monarchy. In February 1913, Montecuccoli upon reaching the age of seventy retired and the Flotteninspektor, Anton Haus was appointed to Marinekommandant. The post of Flotteninspektor was cancelled.

Franz Ferdinand originally wanted to promote Haus only to Marinekommandant, while the post of Chef der Marinesektion he intended to Kon-treadmiral Richard Barry. The Emperor balked the Heir of the Throne's plans and promoted Haus to Chef der Marinesektion as well. In March 1913, Franz Ferdinand tried to persuade Haus to vacate one of his offices, but Haus refused it. He consented only to remain in Pola. He also succeeded

to prevent the appointment of Franz Ferdinand's protégé, Richard Barry to the post of Deputy Chef der Marinesektion. When Haus visited General Arthur Bolfras the Chief of the Military Chancellery of the Emperor, they opened a bottle of champagne celebrating the "multiple victories" over the Heir of the Throne. Bolfras added that it had to take account the wish of the Emperor yet, and not the Heir of the Throne's.²⁵ Nevertheless, Franz Ferdinand did not give up his plans and constantly bombarded Haus with his reform ideas. Haus despite his conflicts with the Heir of the Throne, as Marinekommandant enjoyed a special immunity, so these conflicts did not affect seriously his career.

The two most important tasks ahead of the new Marinekommandant were the negotiating and concluding of the naval convention of the Triple Alliance and the securing of the second dreadnought class. Parallel with the 1912 renewal of the Triple Alliance the Italians proposed to resurrect and renew the naval convention of 1900. In January 1913, Franz Joseph sanctioned the negotiations. Formal talks were started in May 1913 and a conference was held in Vienna in June 1913. The naval convention went into effect on 1 November 1913. The convention was consisted of a general agreement and of an additional agreement on the Mediterranean. The latter prescribed that the commander of the joint Italian-Austrian fleet, envisioned by the convention should be alternately an Austro-Hungarian or an Italian admiral. The objective of the fleet commander was the swiftest possible defeat of the French fleet and seizing the control of the Mediterranean waters in the case of a conflict.

One year after the Austrian and the Hungarian delegations had voted the 312 million Kronen extraordinary credit Montecuccoli submitted a more ambitious plan. In March 1912 the Marinekommandant asked a 464 million Kronen credit for building a second dreadnought class along with cruisers, destroyers and submarines. The Emperor advised him to present his program at a more favorable time. In July he asked a modest sum for one battleship and in October 170 million Kronen for two, but in both cases his requests were rejected by the Hungarian ministers at the meetings of the common Council of Ministers. When Haus

succeeded Montecuccoli, Franz Ferdinand tried to press him to pursue the construction of one battleship by the same "unconstitutional" means that the Navy had used in 1910. Despite the pressure from the Belvedere, Haus did not want to go behind the back of the politicians and in April 1913, revealed the plan of the so called "Spekulationsbau" to Hungarian Prime Minister László Lukács. The key figure was János Teleszky, Finance Minister of the Lukács and the Tisza governments. Lukács and Teleszky refused the extralegal way but Teleszky promised to bring forward the voting for the new extraordinary credit. In October 1913, at the common Council of Ministers even the Hungarian members, the new Prime Minister István Tisza and Teleszky approved the 426 million Kronen extraordinary credit for the Navy. Owing to a decision to change the Austro-Hungarian fiscal year from January-December to July-June, it was decided that the new credit would grant from 1914/1915, the first full fiscal year for the Navy. In the spring of 1914 the Delegations voted for the credit. Due to the outbreak of the war none of the 24,500 ton battleships was laid down, and the program was cancelled in February 1915.

The First World War, or as the contemporaries called it the Great War, was the last war fought by the Austro-Hungarian Navy as the Habsburg Empire itself. The Navy which was developed for fighting a war with the Italian Navy found itself in a difficult situation in August 1914. Despite its limitations and the overwhelming superiority of the enemy coalition of the allied French, British and Italian naval forces on the Mediterranean and on the Adriatic the Austro-Hungarian Navy succeeded in defending the Empire's long Adriatic coastline until the end of the war. The multiethnic Navy functioned clearly better during the war than many other institutions of the multiethnic Dual Monarchy. The Navy made the Adriatic a virtual "Austrian lake", and tied down considerable Allied naval forces. In 1918 the internal decay and disintegration of the Monarchy had a strong impact on the Navy, but somewhat less significant than on the Army. With the collapse and dissolution of the Habsburg Empire the Navy ceased to exist leaving no successors behind.

THE AUSTRO-HUNGARIAN – ITALIAN NAVAL ARMS RACE

From 1814 until its end the Navy of the Habsburg Empire always viewed the fleets of the Italian states and after 1861 the Royal Italian Navy (*Regia Marina Italiana*) as its main rivals and enemies. In the 19th century the series of conflicts at the sea between Italy and Austria began in 1821 and culminated in the Battle of Lissa in 1866. The signing of Triple Alliance in 1882 made the two rivals allies however, mutual suspicions and areas of conflict remained between both powers. From 1904 a new naval arms race centered on the construction of battleships began between Austria-Hungary and Italy, which would intensify later with the appearance of the dreadnought-type battleships. During World War I in May 1915, the two former allies became enemies and the Austro-Hungarian – Italian rivalry on the Adriatic ended with an Italian victory and with the dissolution of the Dual Monarchy.

In the first half of the 19th century the Austrian fleet was much weaker than the fleet of the Kingdom of Two Sicily (Naples) or of the Kingdom of Sardinia. In the spring of 1848, soon after the outbreak of the Revolution of Venice the combined fleets of Sardinia and Naples established a naval blockade of Trieste. Only the indecisivity of the Italian commanders and the inter-allied conflicts spared the Austrian fleet from total annihilation. The lessons of the revolutions of 1848 were learned in Vienna, and in April 1850 the *Flottengesetz* (Fleet Act) was sanctioned by the Emperor. This was the one and only Fleet Act in the history of the Habsburg Empire's navy. Under the *Flottengesetz* six ships of the line and ten frigates would have been built in the next dozen years, but as it was usual in Austria, as the memory of the revolution and of the humiliation at the sea faded, the execution of the construction program slowed down. The energetic Archduke Ferdinand Max in his first years of command tried to accelerate the building of new warships, but even he achieved moderate success. After nearly a decade on the eve of Franco-Austrian War of 1859, only three frigates ordered under the *Flottengesetz* and a ship of

the line still under construction had been realized from the building program of 1850.

The advent of the ironclads and the creating of the Kingdom of Italy with the unification of the majority of the territories of Italy helped Archduke Ferdinand Max to push through an ironclad building program in Austria. In the spring of 1861, the Kingdom of Italy was proclaimed and the Royal Italian Navy (*Regia Marina*) was established. The first Italian ironclads were ordered a little earlier, in 1860 by the Kingdom of Sardinia. Until the summer of 1866 when the war broke out between the Habsburg Empire and the Prussian-Italian alliance, the Italian Navy built or purchased twelve ironclads, while the Austrian Navy built only seven. The departure of Archduke Ferdinand Max in 1864 made things worse for the Austrian Navy, leaving it without a leader and ridden with internal intrigues. Fortunately for the Navy on the eve of the war of 1866 Kontreadmiral Wilhelm von Tegetthoff was appointed to the commander of the operative fleet. While in the war Austria suffered a catastrophic defeat at Königgrätz on 3 July from the Prussians, it defeated Italy on the land (*Custoza*) and on the sea. When the Italian fleet began to siege the Austrian forts on the Lissa Island Tegetthoff ignoring the order from Vienna to keep the fleet in port put to sea with the operative fleet. On 20 July arriving at Lissa he immediately attacked the Italians with his inferior force. Tegetthoff achieved a great victory over the Italian fleet, sinking two ironclads without losing a single ship. The victory was achieved partly as a result of Tegetthoff's bold tactic, partly as a result of the serious antagonism between the Italian admirals. Bismarck's intention to not to humiliate the Habsburg Empire and the Austrian victories over Italy saved the Empire's Adriatic coastline from further Italian territorial gains as in the Peace of Prague only Veneto was ceded to Italy. The War of 1866 closed the series of open conflicts between the Habsburg Empire and Italy in the 19th Century.

After the war the Italian Navy fell into a seven year period of decline. Having already overspent considerably its naval budgets in the years before

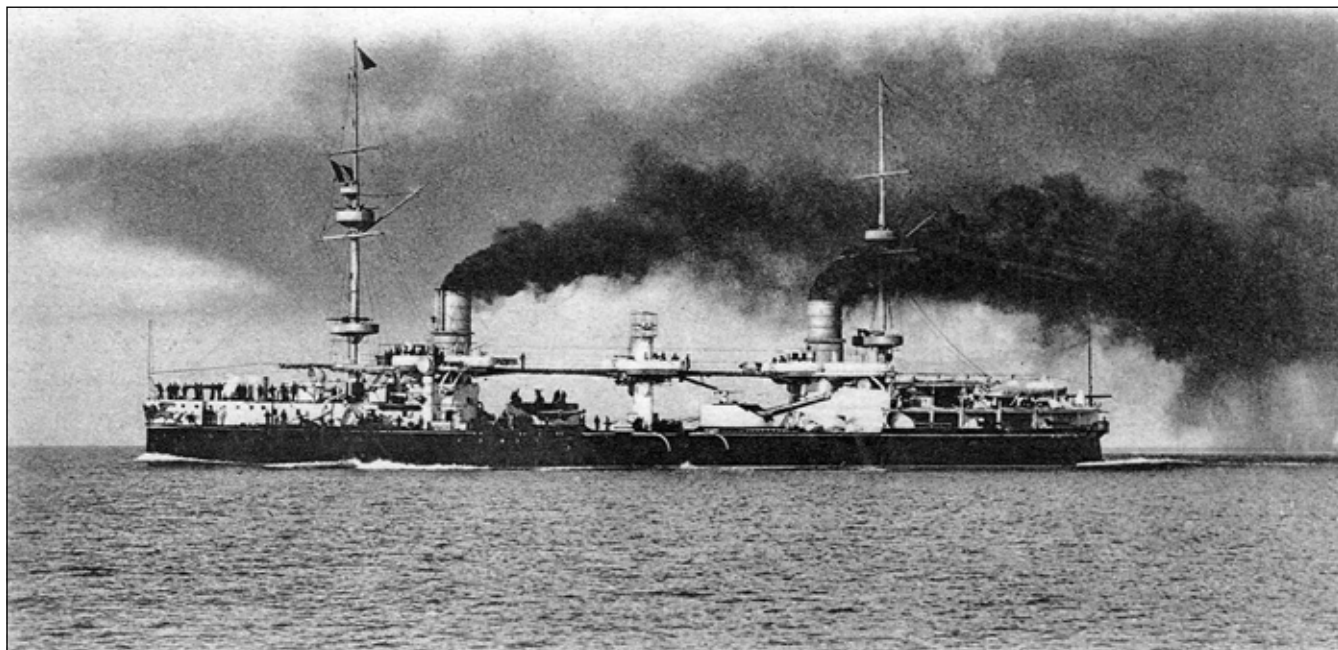

7 Italian turret ship Dandolo

1866, the Italian Navy saw its budget cut throughout the next half dozen years. On the other side of the Adriatic the internally reformed Habsburg Empire, now the Austro-Hungarian Monarchy continued the ironclad building. Money was secured in 1867 for the first post-Lissa ironclad the casemate ship *Lissa*. In February 1868, Franz Joseph appointed Vizeadmiral Tegetthoff to Marinekommandant and Chef der Marinesektion. During his short tenure Tegetthoff succeeded to secure the funds for three additional ironclads, one of them was the wooden ship of the line *Kaiser* which was converted into an ironclad casemate ship the others were the casemate ships *Erzherzog Albrecht* and *Custoza*. In September 1868, Tegetthoff presented his ambitious plan to build a fleet of 15 ironclads up until 1878. This program was officially never adopted, but later it remained an important reference point for the proponents of naval buildup. The goal of Tegetthoff's plan was finally achieved in July 1914 when the dreadnought battleship *Prinz Eugen* entered into service.

After the early death of Tegetthoff in April 1871 the Austro-Hungarian Navy fell into an era of neglect and decline. His successor, the incompetent Friedrich von Pöck, was unable to secure funds for continuing the ironclad building. After a series of failures before the delegations, Pöck finally won approval for a new ironclad, the casemate ship *Tegetthoff*, but the delegations refused to allocate

funds for a sister ship. In 1878, the Austro-Hungarian Navy in contrast with Tegetthoff's plan had only nine ironclads in active service and one under construction. While the Austro-Hungarian Navy sank into stagnation and frustration, for the Italian Navy a new era began in 1873. The driving force behind the revival of the Italian Navy was naval engineer Benedetto Brin, who was appointed to Undersecretary of State in 1873 and Naval Minister in 1876. In 1873, Italy laid down two 11,000 ton turret ships designed by Brin, the *Duilio* and the *Dandolo*. They were giant capital ships for their time and they were armed with the biggest British guns available: four 45 cm guns mounted on two turrets on each ship. In 1876, two more turret ships were laid down, the 13,900 ton *Italia* and *Lepanto*. They were armed with four 43 cm guns. In sad contrast to the Italian Navy Austria-Hungary laid down only one armored ship in the 1870s, the 7,800 ton casemate ship *Tegetthoff* armed with six 28 cm guns in 1876. Austro-Hungarian naval men knew well that their tiny and obsolete ironclads would have no chance against the new Italian sea monsters. Furthermore, they had little reason to hope that they would have comparable capital ships in the near future.

The beginning of the next decade brought even more bitterness for the Austro-Hungarian Navy. In 1880, the committee presided by Archduke Albrecht concluded that the Navy should abandon all

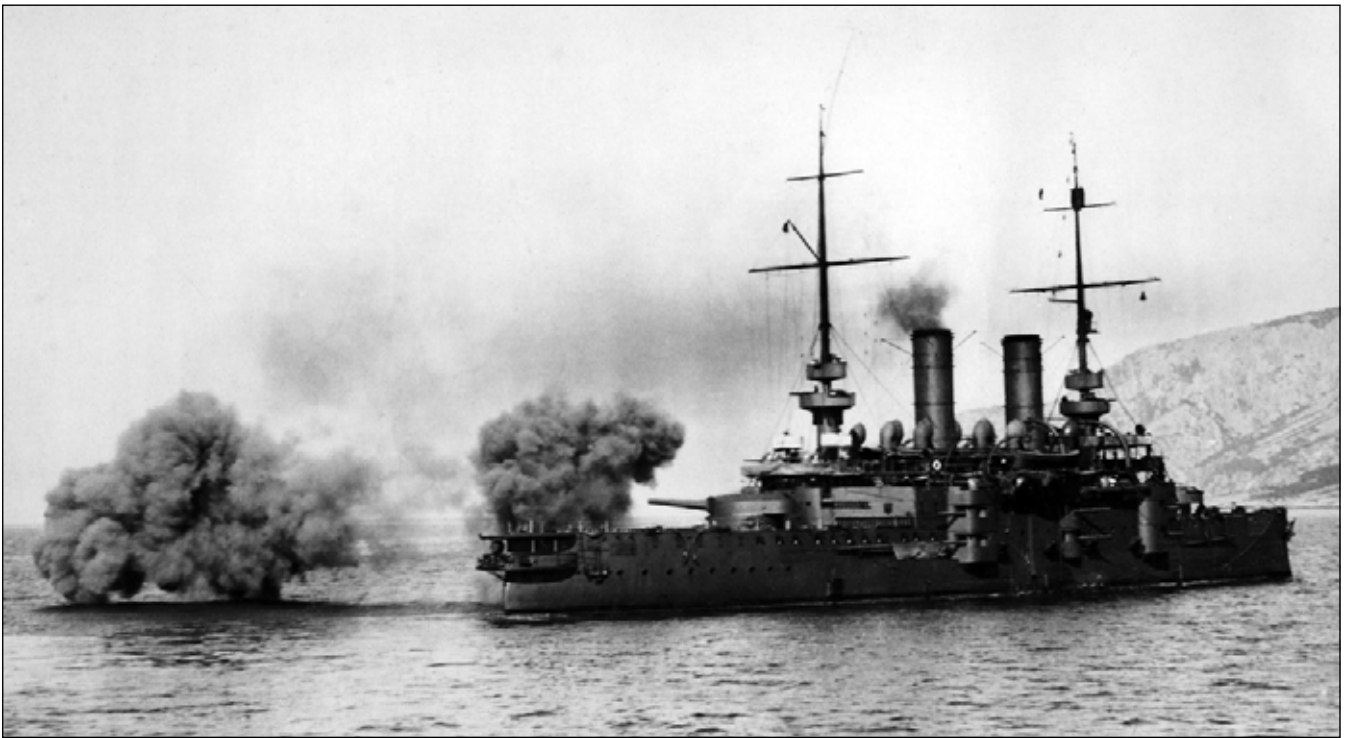

8 Austro-Hungarian Habsburg class battleship (*Panzerschiff*) Árpád

thought of catching up to Italy, and the number of armored ships should be maintained rather than increased.²⁶ In 1881, Italy laid down three more turret ships, the 10,000 ton *Ruggiero di Lauria*, *Francesco Morosini* and *Andrea Doria* armed with four 43 cm guns. At the end of 1881, Pöck succeeded to secure the funds for a new armored ship but her construction would start only years later. The Triple Alliance between Germany, Austria-Hungary and Italy signed in May 1882 was a real disaster for the Navy, because the friendship with Italy questioned the need of the fleet. On the bright side, the consequences of the Triple Alliance terminated the Pöck era. In November 1883, after a nervous breakdown, he was forced to retire.

Pöck's successor, Max von Sterneck succeeded to secure the funds for an additional armored ship. The two ships the 6,900 ton *Kronprinz Rudolph* and the 5,100 ton *Kronprinzessin Stephanie* were laid down in 1884, eight years after the last armored ship. They were the first Austro-Hungarian ships armed with 30.5 cm guns (Krupp). They are often referred as turret ships but in fact they were barbette ships, but it's true that they had revolving armored cupolas on the top of their barbettes which protected the guns. While they were technologically more advanced than the earlier casemate ships, they seemed to be toy ships compared to the

Italian capital ships. While Austria-Hungary laid down no more armored ship in the 1880s, Italy began the construction of three 13,500 ton barbette ships in 1884-1885. The *Rè Umberto*, the *Sardegna* and the *Sicilia* were armed with four 34.3 cm guns each. As in the first years of his tenure, Sterneck sympathized with the "Jeune École" which prophesied the death of the battleship, a number of torpedo boats, three 1,500 ton and two 4,000 ton unarmored cruisers were built in Austria-Hungary.

At the beginning of the 1890s, it turned out that the battleship was not dead instead was alive and well with the advent of the standard battleship. The third 4,000 ton cruiser reflected the shift away from the ideas of the "Jeune École", during the construction her plans were modified and she was launched as a 5,200 ton armored cruiser in 1893 (*Kaiserin und Königin Maria Theresia*). In 1893, three 5,600 ton coastal defense ships were laid down the *Monarch*, the *Wien* and the *Budapest*. They were tiny copies of the standard battleships of that time armed with 24 cm/40 Krupp QF guns. In the same year Italy laid down two 9,900 ton battleships, the *Ammiraglio di St Bon* and the *Emmanuele Filiberto* armed with 25.4 cm guns. In 1896, Austria-Hungary laid down the Navy's second armored cruiser, the 6,300 ton *Kaiser Karl VI*. In 1898, Italy laid down two 13,200 ton standard

battleships, the *Regina Margherita* and the *Benedetto Brin* armed with 30.5 cm guns. The next year began in Austria-Hungary with the construction of the 8,200 ton *Habsburg* class battleships. They were officially designated as Panzerschiffe (armored ships), they were in fact small and weakly armed (3×24 cm) standard battleships. The units of this class were the *Habsburg*, the *Árpád* and the *Babenberg*.

In sharp contrast to the 1870s and 1880s, the 1890s brought the revival of the Austro-Hungarian armored ship building, the pace of the construction of the capital ships and armored cruisers resembled to that which had been witnessed in the 1860s. The main factors which made this possible were the new pro-domestic industry policy of the Navy which won over for the naval armament the influential leaders of the rapidly developing Austrian and Czech heavy industry, and the pro-navy turn in the Austrian policy with the emerging of the new parties which had much more sympathy towards the Navy. While the new Austro-Hungarian capital ships were small and weakly armed compared to their Italian counterparts, the pace of their construction questioned the future maintenance of the overwhelming material superiority of the Italian Navy.

In December 1900, the three powers of the Triple Alliance concluded a naval convention against the Franco-Russian threat. Considering the strength of the three navies – Germany was at the very beginning of becoming the second largest

sea power of the world, not to mention the weakness of the tiny Austro-Hungarian fleet – the convention was a purely defensive one, and the clauses on joint operations were vague. The Triple Alliance was renewed in February 1902, but by then Italy was actively playing a double game. In that year due to changing Italian policy the naval convention became a dead letter.

Austro-Hungarian and Italian relations deteriorated after the Barrère-Prinetti agreement²⁷ of 1902. By 1902, the leaders of the Italian Navy clearly considered the Austro-Hungarian fleet, not the French Navy to be the most likely future opponent.²⁸ In the next years a naval arms race started between Italy and the Dual Monarchy which culminated in a dreadnought race. While the two powers were formally allies, they were building up their armed forces during the decade prior to the Great War, mostly against each other.

The successor of Sterneck, Hermann von Spaun after the defeat of his long term fleet program and his administrative reform, concentrated his efforts on capital ship building. In 1901, the third Austro-Hungarian armored cruiser the 7,400 ton *Sankt Georg* was laid down. In the next year began the construction of the 10,600 ton *Erzherzog Karl* class. The *Erzherzog Karl*, the *Erzherzog Friedrich* and the *Erzherzog Ferdinand Max* armed with 24 cm and 19 cm guns were the last Panzerschiffe of the navy. They were obsolete when they entered into service in 1906-1907 in the wake of the dreadnought revolution. Italy's last standard battleships

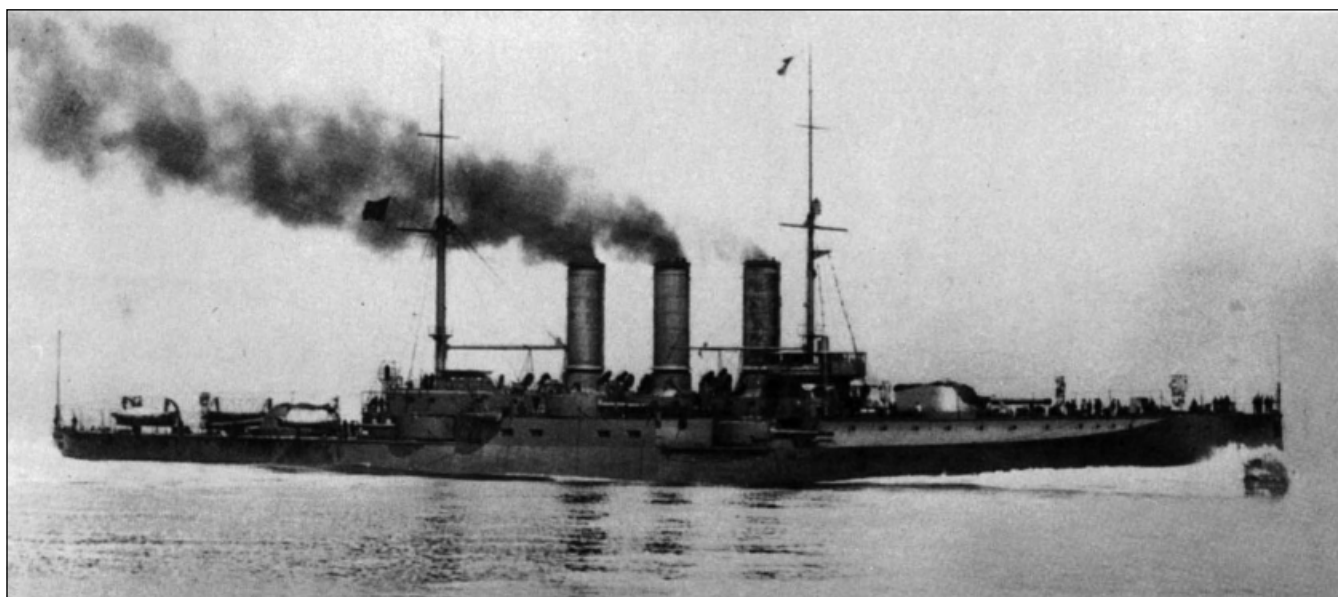

9 Italian Regina Elena class battleship



10 Viceammiraglio Paolo Thaon di Revel,
Chief of Staff of the Italian Navy

were laid down in 1903. The 13,800 ton *Regina Elena*, *Vittorio Emanuele*, *Roma* and *Napoli* were armed with 30.5 and 20.3 cm guns.

The Austro-Hungarian Navy decided for a “qualitative leap” in the capital ship building in 1904. They decided that they would build Schlachtschiffe (battleships) instead of the small and weakly armed Panzerschiffe. During the design process some of the admirals and the engineers promoted the “all big gun” concept, but the new Marinekommandant, Rudolf von Montecuccoli insisted to build mixed large caliber gun battleships. The 14,500 ton battleships the *Erzherzog Franz Ferdinand*, the *Radetzky* and the *Zrínyi* were laid down in 1907-1909. They were armed with four 30.5 cm and eight 24 cm guns. After more than three decades with these battleships, which were larger and more powerful than the largest Italian capital ship, the Austro-Hungarian Navy took the lead, if temporarily, in the Adriatic naval arms race. There was

a gap between 1903 and 1909 in the Italian battleship building because the Italian Navy was engaged in this period with the construction of four large, 10,000 ton armored cruisers (*Pisa*, *Amalfi*, *San Giorgio* and *San Marco*), so they had nothing comparable. The panic which was caused by the new Austro-Hungarian battleships in Rome finally accelerated the then slow Italian dreadnought program, and in June 1909, the first Italian dreadnought the 19,000 ton *Dante Alighieri* was laid down. She was armed with twelve 30.5 cm guns. In 1910 Italy laid down three 22,500 ton battleships armed with thirteen 30.5 cm guns, the *Conte di Cavour*, the *Giulio Cesare* and the *Leonardo da Vinci*. In 1912 began the construction of two other, slightly modified 22,500 ton battleships, the *Andrea Doria* and *Cao Duilio*. The dreadnought programs of the two powers ran parallel, the Dual Monarchy laid down two 20,000 ton battleships in 1910, the *Viribus Unitis* and the *Tegetthoff* and in 1912 their two sisters, the *Prinz Eugen* and the *Szent István*. These dreadnoughts were armed with twelve 30.5 cm guns.

While in 1911 almost no one hoped that the Triple Alliance would be renewed in 1912 thanks to the strained Austro-Italian relationship, the deteriorating Franco-Italian relations due to the Italo-Turkish War, the Balkan Wars and other circumstances pushed closer Italy to Germany and Austria-Hungary. The Triple Alliance was renewed in December 1912. During the negotiations the Italians proposed to renew the naval convention of 1900 in a revised form. The Germans were enthusiastic because they envisaged the joint Italo-Austrian fleet attacking French troop convoys en route from Algeria to France.²⁹ Before December 1912 the leadership of the Austro-Hungarian Navy also anticipated the revival of the naval cooperation of the Triple Alliance. In October 1912 Montecuccoli ordered the Operationskanzlei to prepare a memorandum on the prospects for a Mediterranean naval war between the Triple Entente and the Triple Alliance. The analysis counted 33 battleships and 29 armored cruisers on the Entente side and 29 battleships and 11 armored cruisers on the Italo-Austrian side, but despite the Franco-British majority the memorandum considered that there would be a chance of an Italo-Austrian success.³⁰ On 16 January 1913, Montecuccoli trusted Haus with the prospect of the possible Austro-Hungarian – Ital-

ian naval cooperation. Haus was skeptical about the matter.³¹

On 18 January 1913, Emperor Franz Joseph sanctioned the negotiations. Archduke Franz Ferdinand, who did not trust in the Italians for a moment, took cognizance of the matter, but chose not to get involved at all. Changes in the naval leadership of both Austria-Hungary and Italy delayed the start of the formal talks. In February Anton Haus replaced Montecucoli as Marinekommandant and in April viceammiraglio (Vice Admiral) Paolo Thaon di Revel was appointed to Chief of the Italian Navy General Staff. Thaon di Revel entrusted capitano di fregatta (Commander) Angelo Ugo Conz with conducting talks and organizing a naval conference. Conz travelled first to Berlin and he arrived on 5 May 1913 to Vienna. Haus warned him that Franz Ferdinand could ruin the plan of the naval convention. Conz met also Franz Conrad von Hötzendorf Chief of the Austro-Hungarian General Staff. On 9 May, Conrad acquired the Emperor's authorization for concluding the naval convention.³²

The conference was held at Vienna between 1 June and 23 June. Haus could not participate due to health problems, so the Austro-Hungarian chief negotiator was Linienschiffskapitän Alfred Cicoli. During the conference the negotiating parties reached an agreement on every question, and they were satisfied with the results. The convention consisted of a general agreement and of an additional agreement on the Mediterranean. The latter prescribed that the joint Italian-Austrian fleet's commander should be alternately an Austro-Hungarian or an Italian admiral. For 1914 Haus was named as commander of the joint fleet. The objective of the fleet commander was the swiftest possible defeat of the enemy and seizing the control of the Mediterranean waters. The convention went into effect on 1 November 1913.³³

In December 1913, Thaon di Revel and Haus secretly met at a hotel in Zurich in Switzerland. They checked in at the hotel as Paolo and Antonio. At this secret meeting they discussed the details of the supply of Austro-Hungarian units of the joint fleet and tried to predict the French moves in case of a conflict. They agreed that they would test their strategical ideas in a naval war game during the autumn maneuvers of 1914. Thaon di Revel and Haus also agreed to give free hand to the German bat-

tlecruiser *Goeben* operating independently against the French convoys in the first phase of the campaign. Hugo von Pohl the new Chief of the German Admiralstab agreed on this proposal when he was informed by a letter.³⁴ While both in Italy and Austria-Hungary many doubted that in a coming European war the two powers would conduct joint operations, not without good reason, Italy and the Dual Monarchy made some steps in 1914 to execute what the naval convention prescribed. The Austro-Hungarian Navy began to repaint its olive green ships in the light grey livery more suitable for operating in the open waters of the Mediterranean. In Sicily, Italians stocked coal at Augusta and oil at Messina for the Austro-Hungarian Navy.

Despite the naval convention of the Triple Alliance, Italy and Austro-Hungary continued to view each other as a potential future enemy. The naval buildup of both powers still was targeted primarily at the other. At the beginning of the 1910s, the two navies began to design their next generation dreadnoughts. In 1911-1912 the Italians planned to build 26-27,000 ton battleships armed with 34.5 cm guns. In 1913, they dared to dream big abandoning the earlier plans and switched to a more impressive design. The new concept followed the British fast battleship design of the *Queen Elizabeth* class. The 31,400 ton battleships of the *Francesco Caracciolo* class were laid down in 1914. These battleships would have been armed with eight 38.1 cm guns, but none of the four units was completed due to the war and lack of funds. The Austro-Hungarian Navy was on a tighter budget, the Navy presented 24,500 ton battleships armed with ten 35 cm guns to the politicians. Both delegations voted for the second dreadnought program in the spring of 1914, but none of the four units was laid down due to the outbreak of the war and cancellation of the program.

During the period between 1860 and 1914 Italy built 510,000 tons of armored ships including the ten armored cruisers. In the same period Austria-Hungary built 286,000 tons of armored ships including the three armored cruisers. Assuming that the per ton prices in both powers were more or less similar, we can say that Italy spent 1.75 – 1.8 times more money on armored ship construction than Austria-Hungary. If only the battleship construction of the two powers in the last decade prior to the First World War is examined,

the picture is different. Italy built six battleships or 131,500 tons of capital ships, while Austria-Hungary seven battleships or 123,500 tons of capital ships. There is no more twofold Italian material superiority over Austria-Hungary at least in modern battleships. It's true the picture would look more nuanced when including the four large Italian armored cruisers, but no admiral could be such a fool to place them in the line of battle alongside the battleships, because they were not powerful enough and protected enough to stand. Despite their size and price they were destined for secondary roles.

With the advent of navalism in the Habsburg Empire Italy began to lose gradually her overwhelming naval superiority over her Adriatic rival. In terms of economic performance the two powers were similar, so theoretically they could have maintained navies of more or less similar strength. From the 1870s until the turn of the century Italy

could easily maintain her superiority because the traditions and priorities of the Habsburg Empire were leading to a small and underfinanced Navy. Italy had a much longer coastline, stronger and older maritime traditions and colonial ambitions the latter was always posing the danger of a possible clash with the strongest Mediterranean power, France, which forced the country to spend a much greater proportion of national income on the Navy. Austria-Hungary as a land power without maritime traditions and little interest in naval matters, thanks to her anti-navy political elite spent only the minimum amount to maintain the Navy. Things began to change in the 1890s: the emergence of the pro-navy parties in Austria, the growing interest of the leaders of the heavy industry in the development of the Navy and the support of the new Heir of the Throne laid the foundations of the future naval growth in Austria-Hungary.

THE AUSTRO-HUNGARIAN NAVAL INDUSTRY

Over the long period between 1850 and 1904 the Habsburg Empire gradually developed a capable naval industry which was able to build ships and machinery and to manufacture armor plates and naval ordnance of any caliber. The last surface vessels of the Austro-Hungarian Navy built in a foreign country were the prototypes of the *Huszár* class destroyers and the *Kaiman* class torpedo boats built in 1904 in Britain.

Between 1798 and 1848, every Austrian warship was built in the Arsenal of Venice. After 1850, Trieste became the center of the Austrian naval shipbuilding. The first Trieste built warships were constructed in the Navale Adriatico San Marco shipyard. Wilhelm Strudhoff, the owner of the Stabilimento Tecnico Triestino (STT) machine factory founded the San Rocco shipyard in 1857. This yard later would become the main subcontractor of the Navy, but did not receive naval orders until 1869. The first Austrian built steam frigate was launched in 1856 and the first and only ship of the line in 1858. Their steam engines were imported from Britain.

From the 1860s, the Austrian industry could produce steam engines, but with the advent of the ironclads and the rifled guns the Navy was constrained to import again. In Austria only the Zeltweg Ironworks could produce armor plates but its capacity was far behind the needs of the Navy. The Austrian industry could produce only smaller rifled guns so the Navy relied on import in the field of large and medium caliber guns until the end of the century. In 1868, Tegetthoff modernized the fleet's armament with Armstrong guns imported from Britain but in a short time the German Krupp became the main gun supplier of the Austro-Hungarian Navy.

The STT San Rocco shipyard received its first naval order in 1869 for the casemate ship *Custoza*, the first iron hulled ship of the Navy. The *Custoza* was built with British armor and carried Krupp guns. Due to the concurrency of the STT and the economic crisis of 1873, the San Marco shipyard closed in 1875. From 1875 to the first decade of the 20th century there were two shipyards in the Mon-

archy which could build warships: the Navy's own shipyard in the Arsenal of Pola and the privately owned STT. The shipbuilding, maintenance and modernization and the provision of naval ordnance (chapters VI and VII of the Navy's budget) consisted 63-64 percent of the naval budget between 1870 and 1900, and 73 percent between 1900 and 1914.³⁵ In the 1870s and 1880s 26 percent of this sum went to foreign firms.³⁶

Until the 1890s, the Austrian industry was incapable to produce many strategic items needed for the Navy: armor plates and large and medium caliber guns were the most important of them. The 1890s brought important changes in this field too. The changing political climate in Austria and the lobby of the representatives of the rapidly growing Austrian heavy industry brought an important turn in the Navy's policy. The Navy adopted a pro-domestic industry policy which meant that the Navy ordered every possible item from domestic (Austrian) firms even when the domestic prices were higher. This policy in turn helped the rapid development of the Austrian naval industry because more capital was invested in this industry in hope of lucrative future contracts.

The first ship built with armor plates made by an Austrian firm was the Navy's first armored cruiser the *Kaiserin und Königin Maria Theresia*. The Navy ordered her armor plates in 1891 from the Witkowitz Ironworks in Moravia founded by the Rothschilds. This firm had a virtual monopoly on the armor orders until the dissolution of the Austro-Hungarian Monarchy. The Škoda Works founded by Emil Ritter von Škoda in Pilsen made a cooperation agreement with the Krupp in 1890. The Škoda adopted the breech system of the Krupp. The coastal defense ships of the *Monarch* class were the first ships which carried medium and small caliber Škoda guns. The Škoda manufactured its first heavy gun (24 cm) in Pilsen in 1901. The first Austro-Hungarian capital ship which carried an all-Škoda armament was the third unit of the *Habsburg* class the *Babenberg*. In 1902 the Škoda denounced the cooperation agreement with the Krupp.

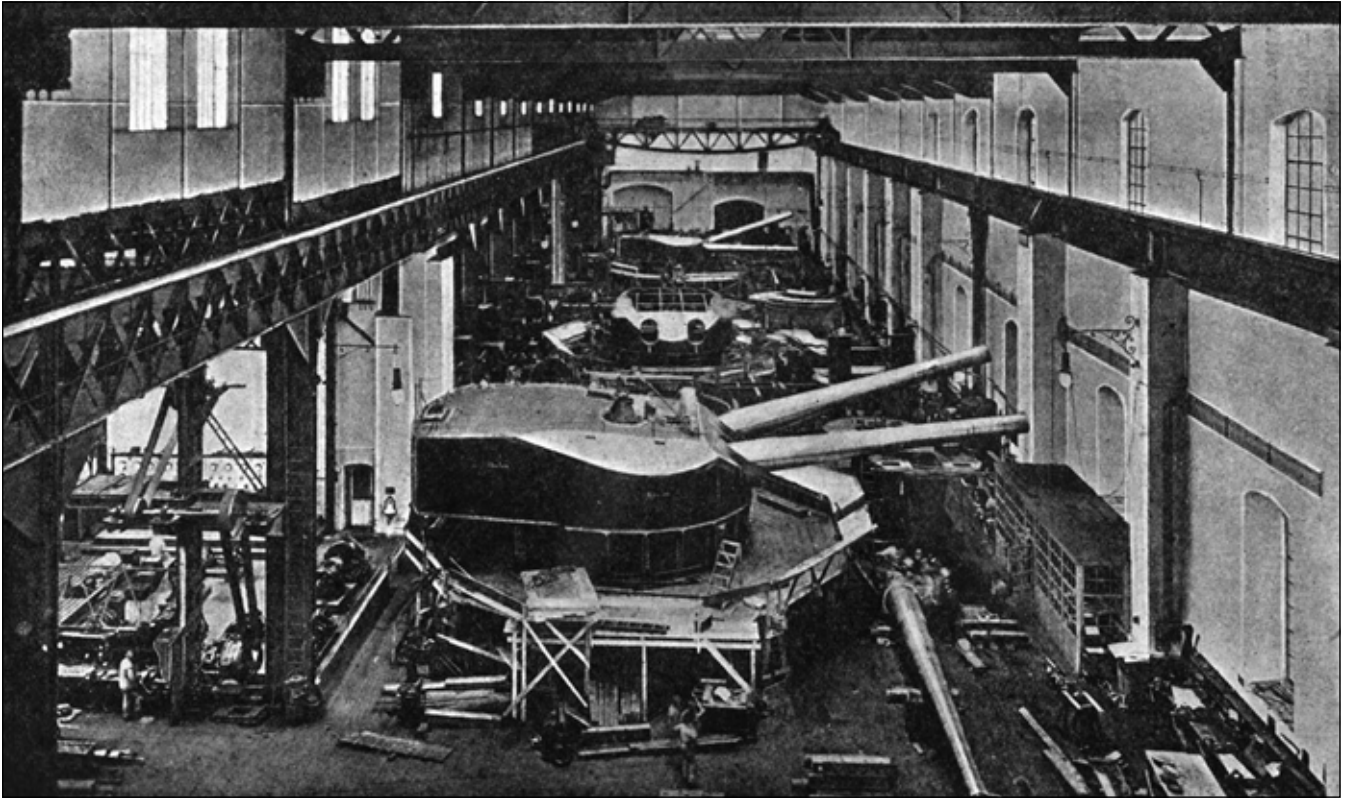

11 30.5 cm/45 twin turrets for the Radetzky class battleships during assembly at the Škoda Works, Pilsen

In 1898, the Österreichische Industrieverband (Austrian Industry League) for the first time formally asked the delegations to support the development of the Navy.³⁷ As the naval shipbuilding became a lucrative business, the Rothschilds via their bank the Creditanstalt became in 1897 the major shareholders of the STT. This capital injection enabled the STT to buy the long time closed San Marco yard.³⁸ From 1899 every warship ordered from the STT was built in the San Marco yard. A few years later the Rothschilds became the major shareholders of the Škoda Works too. Thus the Rothschilds gained controlling interest in the three “flagships” of the Austrian naval industry.

In the first decade of the 20th century new competitors emerged in the naval industry. The virtual monopoly of the STT was broken first when the Hungarian Danubius of Fiume received its first order for seagoing warships from the Navy in 1906.³⁹ The special political system of the Dual Monarchy, the need for the support of the Hungarian government for the development contributed significantly, if not solely, to the rapid growth of the value of the orders from the Hungarian shipyard after 1911. A new shipyard, the Cantiere Navale Triestino (CNT) of Monfalcone entered the scene

in 1911, causing fears both in Trieste and Fiume. From 1913, Škoda was the major shareholder of the CNT. In fact this shipyard received only minor orders compared to STT and Danubius. On the eve of the First World War, only the Witkowitz Ironwork’s monopoly seemed stable because there were no other armor manufacturers in the Dual Monarchy. In 1913, a great gun factory, the Magyar Ágyúgyár Rt. (Hungarian Gun Factory Ltd) was established in Hungary in Győr, with the intention that this factory would be able to manufacture even the heaviest naval ordnance and complete gun turrets from 1920. In fact, it was less threatening to the positions of Škoda, because the Czech gun factory held 6/13 of the shares of the new factory.⁴⁰

With the development of technology and as the battleships become larger and larger the prices were steeply rising. The price of a 10,600 ton *Erzherzog Karl* class battleship was 26 million Kronen (2450 Kronen per ton), that of a *Radetzky* class battleship was 39 million Kronen (2680 Kronen per ton), that of a *Tegetthoff* class battleship was 60 million Kronen (3000 Kronen per ton) and that of a projected *Improved Tegetthoff* class battleship was 82 million Kronen (3350 Kronen per ton). In little more than

a decade the specific (per ton) costs of battleships rose by 37 percent, while the prices of battleship classes rose from 78 million Kronen to 328 million Kronen (420 percent).

The prices of the Austro-Hungarian naval industry were higher than that of Britain or of Germany. Usually an Austro-Hungarian warship was 20 percent more expensive than a similar British or German warship. This was the price that the Navy had to pay for the political support of the fleet development by the industrialist. In the Dual Monarchy participating in the naval buildup was a very good business, while the prices were higher workers' wages were lower than in Western Europe, so higher profit rates could be achieved. The Navy was well aware of this phenomenon but they could do little about it. The emergence of the Danubius shipyard in Fiume did not help in breaking down prices because the Hungarian shipyard tried to ask for even higher prices. The Austrian steel cartel was also very effective in averting the Navy's attempts to break down the prices.

The following numbers illustrate well the acceleration of the pace of the Navy's development after the turn of the century. The Austro-Hungarian Navy spent on new construction, repair and naval artillery 297.6 million Kronen between 1874 and 1899. This sum was tripled between 1900 and 1914 reaching 891.6 million Kronen.⁴¹ The largest part of the latter sum ended up in three firms: the STT, the Škoda Works and the Witkowitz Ironworks.

It is worth examining the effects of the growth of the capacity of the Austro-Hungarian naval industry in the second decade of the 20th century on the battleship construction and on the prospects of

the naval arms race between the Dual Monarchy and Italy. The investments and the developments in the first years of the 1910s created a significant growth of the capacity on such territories of the naval industry which were crucial for the battleship construction. With the two new, large slipways (called "battleship slipways") erected at Danubius in Fiume, it became possible from 1914 to lay down four battleships simultaneously instead of two. In the preceding years only the STT possessed slipways large enough to build battleships,⁴² two in number. A third battleship could be laid down only after the launch of one of the first two battleships. With the establishment of the Hungarian gun factory theoretically the capacity of the gun turret production would have been increased at least by fifty percent at the end of the decade. Armor manufacturing was the only field where no new factory was established, but during the construction of the *Tegetthoff* class it was demonstrated that the Witkowitz Ironworks was able to increase significantly its manufacturing capacity with ease. The rapid growth of the capacity of the Austro-Hungarian naval industry and the forthcoming accession to throne of the pro-navy Franz Ferdinand foreshadowed that one day the Italian naval superiority over Austria-Hungary would be no longer maintainable. Certainly, there were roadblocks to a future battleship building boom, beside the financial limitations from the technical point of view the bottleneck was the limited pool of skilled workers. Nevertheless, the outbreak of the war ended the development of the Austro-Hungarian Navy once for all; the largest new warships laid down during the war were 800 ton destroyers

THE ALMOST-DREADNOUGHTS OF THE DUAL MONARCHY

THE RADETZKY CLASS

After a long period of neglect and stagnation the slow development of the Austro-Hungarian Navy began in the last years of the 19th century. In 1904, as a reaction to the revival of the Italian threat in the preceding years the Navy decided for a qualitative leap in the battleship construction. Some historians state that the turning point of the development of the Austro-Hungarian Navy was the decision for building the first dreadnought battleships. In my opinion, the real turning point, truly less spectacular than the dreadnoughts, came a bit earlier in 1904 when the Navy decided to build true battleships (*Schlachtschiff*) instead of so called “armored ships” (*Panzerschiff*). Designating the next class “*Schlachtschiff I-III*” in the designs was also a message for the politicians that the doctrine of pure coastal defense came to an end.

The design works of the new battleships were done in a very interesting period of naval history, they coincided with the Russo-Japanese War and the so called “dreadnought revolution” while the worldwide naval arms race significantly intensified.

The news of the Battle of Tsushima and especially of the new British “all big gun battleship” had a great impact on the design process. Inspired by the news from Britain some members of the designing board proposed to follow the trend and to build “all big gun battleships”. The more conservative admirals and especially the new Marinekommandant, Rudolf von Montecuccoli resisted such a bold break with the convention which resulted in a more conventional “mixed heavy caliber” design. Despite the fact that these battleships were already obsolete when they were laid down, their construction marked a giant leap for the Austro-Hungarian Navy.

The Design Process

The design works on the next battleship class (*Schlachtschiff I-III*) started on 15 March 1904. A board headed by the Marinekommandant, Admiral Hermann von Spaun met in Vienna. The board members were the most important persons

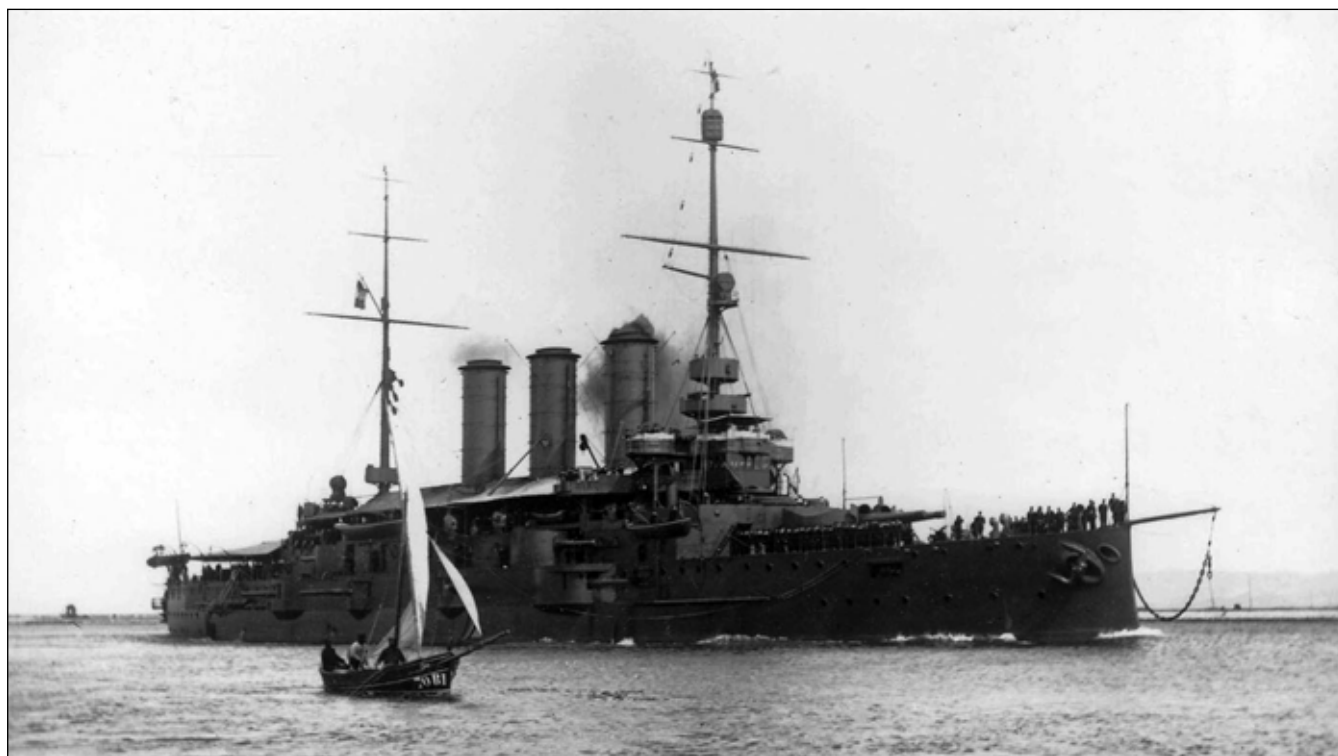

12 Erzherzog Karl, the first unit of the last Austro-Hungarian battleship class armed with 24 cm/40 guns

of the Navy: Vizeadmiral Rudolf von Montecuccoli, Franz von Minutillo, Kontreadmiral Julius von Ripper, Anton Haus and Generalschiffbauingenieur (chief naval architect) Siegfried Popper.⁴³ In his expose Spaun said that despite the extraordinary credit of 120 million Kronen there was no hope starting the construction of new battleships before 1907. This credit enabled only the acceleration of the building of the *Erzherzog Karl* class battleships. The keel of the third and last ship of the class (*Erzherzog Ferdinand Max*) had been laid a week before this meeting. In spite of this, Spaun asked Popper to elaborate preliminary designs for 13,000 ton battleships.⁴⁴

At the next meeting of the board on 18 May 1904 in Pola Spaun laid up the specifications for the new design: 28 or 30.5 cm main battery instead of the 24 cm main battery of the preceding classes and a thicker armor belt in consideration of the newest capped AP projectiles. These requirements needed a ship by approximately 2,000 tons larger than the *Erzherzog Karl* class. Spaun affirmed that the building of the new battleships would start in 1907. In this early phase of the design process, the conception of the armament was yet unsettled, there were many different proposals: 30.5 cm guns in single turrets, 28 cm guns in twin turrets, or a twin 30.5 cm turret fore and a twin 24 cm turret aft. It was suggested also that a part of the 19 cm guns should be mounted on twin turrets. The representatives of the Marinetechnische Komitee (MTK)⁴⁵ presumed that with a slight increase of the displacement it would be possible to mount two twin 30.5 cm gun turrets on the new battleships. Finally no decision on the armament was reached.⁴⁶

In the summer of 1904 Popper and the naval architects of the Marinetechnische Komitee elaborated the following six alternative designs with 230 mm belt armor. The design power output of the 20 knots variants was 18,000 SHP, while of the 19 knots variant was 16,000 SHP. The caliber length of the 30.5 cm and 28 cm guns was 40.

A board headed by Vizeadmiral Franz von Minutillo on 19 September discussed these designs and favored the variants V or VI. But at this time the caliber of the main battery (28 or 30.5 cm) was still uncertain.⁴⁷ These first designs did not show signs of qualitative leap they were in fact the enlarged versions of the *Erzherzog Karl* class battleships.

After a pause of five months (Spaun resigned in October 1904), a board headed again by Minutillo discussed the question of the caliber of the main armament on 10 February 1905 in the Hafenamiralität at Pola. Popper was absent from this board meeting. The main topic of this meeting was the armament of the battleships. At first, they discussed the question of the breech-system and they decided for keeping the wedge breech for the new guns. Kontreadmiral Josef Mauler, the commander of the Arsenal of Pola advised to keep the wedge breech and the metal cartridge casing. Kontreadmiral Guido Courade told when the first 24 cm gun had been constructed in 1901 in the Škoda Works, a board had examined the Vickers-Maxim breech-system and they had considered the wedge breech better. The question of the caliber caused some debate: some members (Linienschiffskapitän Luzian von Ziegler, the head of the MTK and Obere Artillerieingenieur Friedrich Jedlička, the head of the artillery department of the MTK)

The Data of the MTK's Battleship Designs

(t=in turrets, c=in casemates)

	<i>Displacement/speed</i>	<i>Armament (cm)</i>
I	12 650 t/20 kn	4×28t 8×19t 4×19c
II	12 200 t/19 kn	4×30.5t 8×19t
III	12 650 t/ 20 kn	3×30.5t 8×19t 4×19c
IV	12 650 t/20 kn	2×30.5t 8×19t 8×19c
V	12 950 t/20 kn	4×30.5t 8×19t 4×19c
VI	12 950 t/20 kn	4×30.5t 4×19t 8×19c



13 Konteradmiral Julius von Ripper,
due to his aggressive tactical ideas he was called
the "Austro-Hungarian Togo"

pleaded for the 28 cm guns. They stated that the cartridge case of the 30.5 cm gun was too long and heavy (1.5 m and 56 kg),⁴⁸ so it would be unwieldy in a gun turret. Kontreadmiral Ripper objected this statement and said that the handling of the case of a 30.5 cm gun would be possible even in a battleship's gun turret. Jedlička proposed 28 cm/45 guns instead of the 30.5 cm/40 guns for the new battleships. He stated that the ballistic properties of the two guns were equal. Despite Jedlička's arguments the majority of the board members voted for the 30.5 cm caliber. Among the admirals sitting in the board only Kontreadmiral Julius von Beck supported the 28 cm caliber, but on the condition that the 30.5 cm gun would have problems. They adjourned the decision on the secondary battery, but in this phase of the design works it seemed that the final concept was near.⁴⁹

Before the next meeting of the board the news of the 18,000 ton British all big gun battleship design armed with ten 30.5 cm guns reached Vienna in June 1905.⁵⁰ On 20 September 1905, the Marinesektion ordered a board meeting in the Hafens Admiralität at Pola to discuss the design of the future 13,500 ton battleships.⁵¹ The 25 September meeting of the board was headed by Kontreadmiral Julius von Ripper. Ripper in his expose expounded that the experiences of the Russo-Japanese War had showed that the heavy guns had the leading part in a fleet engagement; therefore the new battleships had to have the heaviest possible guns that the Austro-Hungarian industry could produce. As a result of the news of London and Tsushima some members suggested that the new battleships should to be built along the all big gun concept. Linienschiffskapitän Ziegler suggested that a 13,500 ton ship could not mount enough long (45 caliber length) 30.5 cm guns. He proposed to build instead 16,000 ton battleships armed with eight 30.5 cm guns. He added that due to the lack of a floating dock of enough lifting capacity the construction of such large ships would be possible only if the Navy would construct a larger dock at the same time. Kontreadmiral Josef von Mauler, the Hafens Admiral of Pola said that a new floating dock would be desirable for the Navy. But Ripper declared not to exceed the 13,500 tonnage limit. The costs of a squadron of three 16,000 ton battleships and the new floating dock needed for such large ships at that time seemed too great for the Navy. Ripper was backed by Popper, who told that the costs of a new dock would be prohibitive for the Navy. Ripper said that four 30.5 cm guns and a secondary battery of 19 cm caliber could be mounted without problems on a 13,500 ton ship.⁵² Despite the laments on the costs of a new dock, the Navy along with the *Radetzky* class ordered in 1907 a new floating dock of 22,000 ton lifting capacity for 5.5 million Kronen.

Jedlička pleaded again for his favorite 28 cm guns, proposing a 13,500 ton ship with eight 28 cm/45 guns mounted on four twin turrets, two turrets fore and aft and two as wing turrets (note that the German designs of 8×28 cm armament dated from March 1905 were of 15,000-15,700 tons displacement⁵³). He stated that this gun could penetrate 230 mm belt armor from a distance of 8,000 m with APC projectile. Jedlička also proposed to in-



14 *Generalschiffbauingenieur Siegfried Popper*

roduce 10.5 cm/45 guns with wieldy, 28 kg fixed ammunition as anti-torpedo boat battery instead of the ineffective 7 cm guns. He stated that this gun with semiautomatic breech mechanism could reach a rate of fire of fifteen rounds per minute. He considered that twenty of these guns could be mounted on the battleship he envisaged. Ripper spoke against the 28 cm caliber and argued for the 30.5 cm gun saying that the 100 kg heavier projectile of this gun had a more stable trajectory. Kontreadmiral Mauler pleaded for a 19 cm battery, echoing the arguments of the pro-secondary battery theorists. He said that by his opinion penetrating the belt armor had no real importance while a battery of 19 cm guns could inflict serious damage on the unarmored or thinly armored part of the enemy ship. At the end of the meeting the majority of the board members voted for the 30.5 cm caliber again.⁵⁴

At the next meeting on 29 September, Popper presented five alternative designs of the 13,500 ton battleship. Three of the designs (B, C and D) represented the all big gun concept and all the guns were of 45 caliber length.

The Armament of Popper's 13,500 Ton Designs (t=in turrets, c=in casemates)

A	2×2-28 cm t, 4×1-24 cm t, 8×19 cm c
B	2×2-28 cm t, 4×1-28 cm t, 12×10 cm c
C	4×2-28 cm t, 16×10 cm c
D	2×2-30.5 cm t, 2×1-30.5 cm t, 16×10 cm c
E	2×2-30.5 cm t, 4×2-19 cm t, 12×10 cm c

These were the first battleship designs in the history of the Austro-Hungarian Navy, which had an armored torpedo protection system (weighing 560 t). The belt armor was on the other hand too weak, only 210 mm thick. Popper estimated that the true displacement of these designs was around 13,650 tons. Popper also said that in the case of the design A the four 24 cm guns could be mounted on two twin turrets instead of four singles and the resulting weight saving could be used for thickening the belt armor.⁵⁵

After Popper's presentation, Jedlička asked for the floor and presented a table on the armor penetration capability of different foreign (British, French and Italian) 30.5 cm guns and of the projected Škoda 28 cm and 30.5 cm guns. He proposed to introduce the longer 45 caliber length gun if the Navy would decide for the 30.5 cm caliber. Then he returned to his favorite 28 cm guns, pleading for a battleship with 8×28 cm main battery citing the problem of the heavier cases of the 30.5 cm guns. Among the advantages of the 28 cm caliber he recited the greater rate of fire and the easier production. Ripper told him that there had not been any problem with the handling of the cases of the 30.5 coastal defense guns. He stated also that the domestic industry could manufacture the larger gun without any difficulty. Jedlička replied that he was in favor of the 30.5 cm caliber too, and he wanted only to draw attention to the possible problems. Ripper summarized that the board had decided for the 30.5 cm/45 gun, on the condition that the gun should reach a rate of fire of one round per minute and if the twin turret could be able to be hand operated in the case of emergency.⁵⁶

Turning to the number and arrangement of the heavy guns, Popper, Ziegler, Linienschiffskaptän Viktor von Baselli, the director of the Naval Artil-

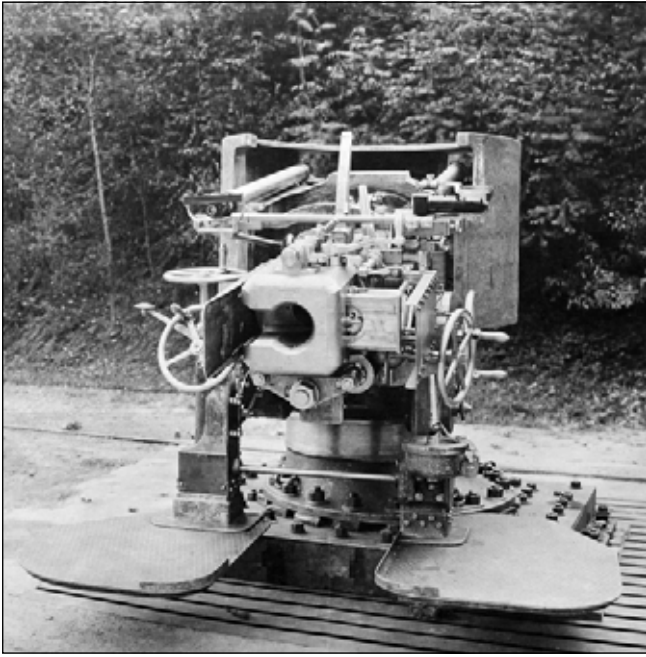

15 10 cm/50 gun for the Radetzky class

lery School and Jedlička favored the variant D armed with six 30.5 cm/45 guns. Ziegler argued for the all big gun concept and told that the experiences of the Battle of Tsushima had showed that even the 20 cm guns were ineffective against modern battleships. Some days later Montecuccoli made a handwritten comment on the copy of the record of this meeting that he could not understand why would be better one 30.5 cm gun than four 19 cm guns.⁵⁷

The conservative members (admirals) of the board favored the variant E, a battleship armed with four 30.5 cm and eight 19 cm guns, all in twin turrets. Kontreadmiral Mauler argued for the 19 cm guns again. He was seemingly in love with this caliber, and favored this gun and its great rate of fire. He stated that to disable a battleship it was only necessary to demolish her thinly armored parts by the secondary battery without penetrating the main belt armor or the gun turrets of the main battery. Ripper also spoke in favor of the 19 cm gun. Both admirals pleaded for the 19 cm guns, while Popper, Ziegler, von Baselli and Jedlička favored the battleship armed with 6×30.5 cm without secondary battery. When the discussion on the secondary battery ended, von Baselli proposed that the gun turrets should be all electric operated. Jedlička supported Baselli's proposal, saying that the electric system was lighter than the hydraulic system, easier to repair and easier to switch to hand operation. The board immediately decided for the electric op-

erated gun turrets. At this meeting no formal decisions were reached on the armament of the future battleship, but the board decided for the introduction of the 10.5 cm guns as anti-torpedo boat battery.⁵⁸ On 3 October, the board members inspected the 30.5 cm/40 Krupp gun in Fort Little Brioni and they found that the handling of the breech and the cartridge case was easy and problem free.⁵⁹

In the official file there is an unsigned proposal attached to the protocol of the above meeting. The unknown writer proposed a 14,200 ton battleship armed with eight 28 cm/50 guns, who also proposed to stretch the 10.5 cm/45 anti-torpedo boat guns to 50 caliber length and to reduce the projectile weight of these guns from 18 to 14 kg.⁶⁰ The proposals regarding to the 10.5 cm guns were later accepted, while from an unknown reason the caliber was changed to 10 cm (100 mm). The writer of this proposal was most probably Jedlička.

The final decision was made by a board headed by the Marinekommandant, Admiral Rudolf von Montecuccoli on 3-4 November 1905. Most of the admirals (Vizeadmiral Julius von Ripper, Vizeadmiral Leodegar Kneissler von Maixdorf and Kontreadmiral Anton Haus) were in favor for the secondary battery of 19 cm, while Ziegler who had been promoted to Kontreadmiral and Popper favored the all big gun battleship concept. When Montecuccoli was emphasizing the importance of the secondary battery Linienschiffskapitän Konstantin von Schwarz acclaimed: "His Excellency the Herr Marinekommandant is perfectly right!" On 3 November Popper presented a new, 14,000 ton design armed with eight 30.5 cm guns. At this moment Montecuccoli suddenly turned to Popper and asked him what would be the displacement of a ship armed with eight 24 cm guns as secondary battery instead of eight 19 cm guns. Popper replied that the displacement of that ship would be about 14,300-14,500 tons. Kontreadmiral Anton Haus argued for a ship armed with four 28 cm and eight 19 cm guns because he stated that the 13,500 ton displacement was too small for 30.5 cm guns. Then the final voting was taken place and the majority of the board members voted for a 13,500 ton battleship armed with four 30.5 cm and eight 19 cm guns. Montecuccoli declared that this was the final design of the future battleships. At the afternoon meeting on the same day they began to discuss the question of the anti-torpedo boat battery, when Ziegler brought

up the subject of the secondary battery. He questioned the equivalence of two 19 cm guns with one 30.5 cm gun. An angry Montecuccoli closed the debate and the board turned to the question of the armament of the projected armored cruiser.⁶¹

In the Kriegsarchiv of Vienna there are no documents related to the changes in the design of these battleships after November 1905 in the official files dealing with the design process of *Schlachtschiff* I-III. On the evidence of some documents preserved in the Mladiáta-collection in Budapest, we can state that the increase of the displacement from 13,500 tons to 14,500 tons occurred in two steps. Soon after the “final” decision, in December 1905 the first step was taken: the displacement was increased to 14,000 tons and the 19 cm guns were changed for 24 cm guns. Before July 1906, the displacement was increased to 14,500 tons by the increase of the beam from 24 to 24.5 meters, while the length of the ship remained the same (137.5 meters on w. l.).⁶² The anti-torpedo boat battery was slightly modified, the caliber length of the now 10 cm guns was increased to 50 and the projectile's weight was reduced from 18 to 14 kg as it had been proposed in October 1905.⁶³

With the decision of the Marinekommandant against the all big-gun concept, the Austro-Hun-

garian Navy lost the possibility to build dreadnoughts almost first in the European continent and parallel with the German Navy. The Austro-Hungarian Navy built mixed large caliber battleships instead of all-big guns battleship from 1907. The main reason of Montecuccoli's decision was not, or was not entirely conservatism. A little more than half year later in July 1906, Montecuccoli spoke before the delegation of the Reichsrat about the need of building 20,000 ton battleships. Most probably the Marinekommandant feared the politicians and did not want presenting them larger and more expensive all-big gun battleships. This decision was not unique at that time. The Japanese *Satsuma* class battleships ordered in 1904 were originally intended to be armed with twelve 30.5 cm guns. The shortage of domestic 30.5 cm guns and high costs forced the Imperial Japanese Navy to redesign the ships to carry four 30.5 cm and twelve 25.4 cm guns. The original armament intended for them would have made them dreadnoughts laid before the HMS *Dreadnought*.

As it was mentioned, the Austro-Hungarian Navy recognized the importance of the torpedo protection system in the light of the experiences of the Russo-Japanese War. The Navy made two underwater explosion tests on the hulk of an old iron-

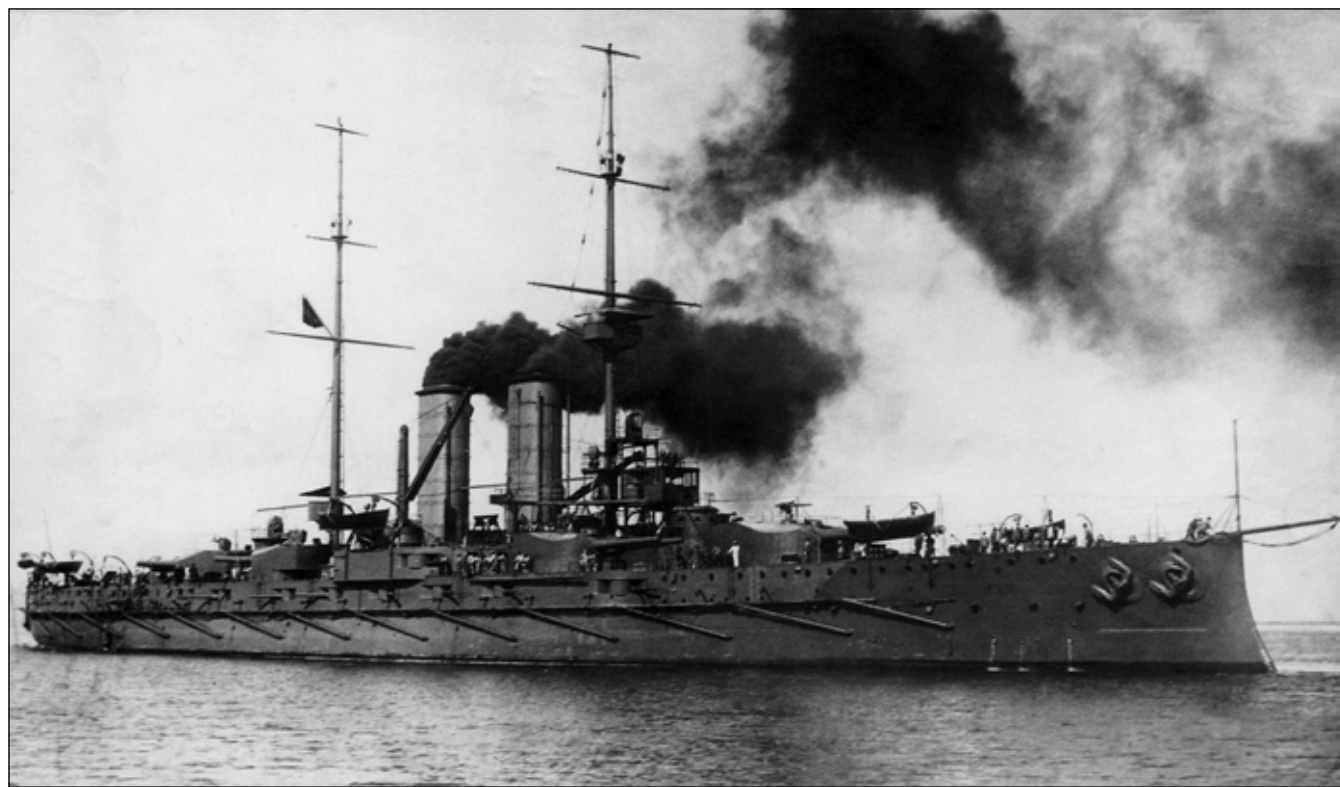

16 Zrínyi, the last unit of the Radetzky class

clad with charges of 10 kg in 1906, but these tests provided no useful results.⁶⁴ Due to this fact Popper made his own protective system based purely on theoretical calculations. The torpedo bulkhead (*gepanzerte Minenboden*, armored mine-bottom by the own words of Popper) of the 14,500 ton battleships was 54 mm thick, but the distance between them and the ship's side shell plating was only 2-1.5 m which was insufficient as German test results and war experiences later demonstrated. The attempt of the Navy to save money on the tests later caused great losses.

With the change of the caliber of the secondary battery from 19 to 24 cm these ships became mixed large caliber battleships. Despite being obsolete already on the drawing board, they were the first true battleships of the Austro-Hungarian Navy and they were rated powerful ships in the Adriatic and even in the Mediterranean. The French were building similar battleships (*Danton* class armed with 4×30.5 cm and 12×24 cm guns) and the Italians, first time in the history of the rivalry of the two navies had nothing to compare. In Italy there was a gap in the battleship construction between 1903 and 1909 and the battleships of the *Regina Elena* class were much inferior to the new Austro-Hungarian battleships. The fear of these battleships was the main reason for the acceleration of the Italian dreadnought program in 1908. The first Italian dreadnought (*Dante Alighieri*) was laid down in June 1909.

The Final Design

The first mixed large caliber battleships of the world were the British *King Edward VII* class battleships and their Japanese copies the *Katori* class battleships, armed with four 30.5 cm and four 23.4 cm guns. After them four "second generation" mixed large caliber battleship classes were built: the British *Lord Nelson*, the Japanese *Satsuma*, the French *Danton* and the Austro-Hungarian *Radetzky*, armed with four 30.5 cm and eight to twelve 23.4-25.4 cm guns. Due to the appearance of the all-big gun battleships all these classes were obsolete even when they entered into service.

Despite its obsolescence, the *Radetzky* class was a giant leap for the Austro-Hungarian Navy especially in firepower. The displacement of the *Ra-*

detzky class battleships was 3,900 tons or 37 percent greater than the displacement of the *Erzherzog Karl* class battleships. The greater part of the increase of the displacement was dedicated to the armament, the thickness of the belt armor was increased only 10 percent (from 210 mm to 230 mm) while the speed of the two classes was identical. The weight of the armament of a *Radetzky* class battleship was 2011 tons while that of an *Erzherzog Karl* class battleship was 1085 tons.⁶⁵

The Austro-Hungarian Navy introduced the quick-firing 30.5 cm guns on these battleships. It's worth noting that these were the world's first 30.5 cm guns with wedge breech and metal cartridge case in service on a battleship.⁶⁶ The 30.5 cm/45 Škoda gun had an armor penetration capability almost double that of the old 24 cm/40 gun especially on greater ranges. The Austro-Hungarian gun was more potent than the 30.5 cm/40 gun of the Italian standard battleships, its projectile (450 kg) was 70 kg heavier and its armor penetration capability was 50 mm greater on every range.⁶⁷ The new 24 cm/45 guns of the *Radetzky* class were also better and more potent than the older 40 caliber length guns. The firepower of the *Radetzky* class radically exceeded the firepower of the preceding classes. The four 30.5 cm guns were mounted on two twin turrets fore and aft and the eight 24 cm guns were mounted on four twin wing turrets, the six turrets were arranged in a hexagonal form. A complicated electromechanical safety system was applied to prevent hitting the other turret. This system later proved to be unreliable. The weight of a 30.5 cm twin turret was 439 tons, while a 24 cm twin turret weighed 238.8 tons. The 30.5 cm and 24 cm gun turrets were all electric operated.

The anti-torpedo boat battery consisted of twenty 10 cm/50 guns. Sixteen of them were in casemates on the Batteriedeck and four in the superstructure around the funnels. The same guns constituted the main armament of the cruiser *Admiral Spaun*, the cruisers of the *Helgoland* class and the destroyers of the *Tátra* class. The ships had three 45 cm submerged torpedo tubes, two broadsides and one on the stem. The ships could carry twenty naval mines in a special magazine.

The fire control system of the *Radetzky* class battleships was quite simple and similar to the pre-war system of the *Tegetthoff* class dreadnoughts. Each of the *Radetzky* class battleships had two



17 Forward port 24 cm/45 turret on *Radetzky*

main fire control stations, one in the fore and one in the aft conning tower. The ships had two “wing” control stations for the secondary battery integrated into the superstructure. All these four control stations had their own 9 feet (2743 mm) Barr & Strouds rangefinders. The battleships had two fully equipped fire control positions which were located fore and aft under the armored deck. These were intended to use only in case of serious damage of the upper positions. The *Radetzky*s also had a fire control position on the foretop. The electric (DC) communication apparatuses were made by Siemens & Halske. The battleships had originally six 90 cm searchlights, from 1915 they were fitted with eight 110 cm and two 90 cm searchlights.

The weight of the vertical armor was 3700 tons.⁶⁸ The main belt was 230 mm thick which was even then inadequate when the ships were commissioned. The upper belt (Zitadell) was 150 mm thick. The main armored bulkheads were also 150 mm thick. Forward and aft of the barbets

of the 30.5 cm turrets the belt armor was reduced in thickness to 100 mm. The casemate armor was 120 mm thick. The sloped parts of the armored deck were 48 mm thick while the amidships part was 36 mm thick. Over the magazines of the 30.5 cm turrets the Batteriedeck which was one deck above the armored deck (Mitteldeck) was thickened to 30 mm. The face and the sides of the 30.5 cm turrets were 250 mm thick, while their roofs were 60 mm thick. The face and sides of the 24 cm turrets were 200 mm thick and their roofs 50 mm thick. The barbette armor of the 30.5 cm turrets was 250 mm over the Batteriedeck and 80 mm between the Batteriedeck and the Mitteldeck. The barbette armor of the 24 cm turrets was 200 mm over the Batteriedeck. The fore conning tower had 250 mm thick sides and 60 mm thick roof, while the aft conning tower had 120 mm thick sides and 40 mm thick roof.

As it was mentioned above, the battleships of the *Radetzky* class were the first Austro-Hungari-

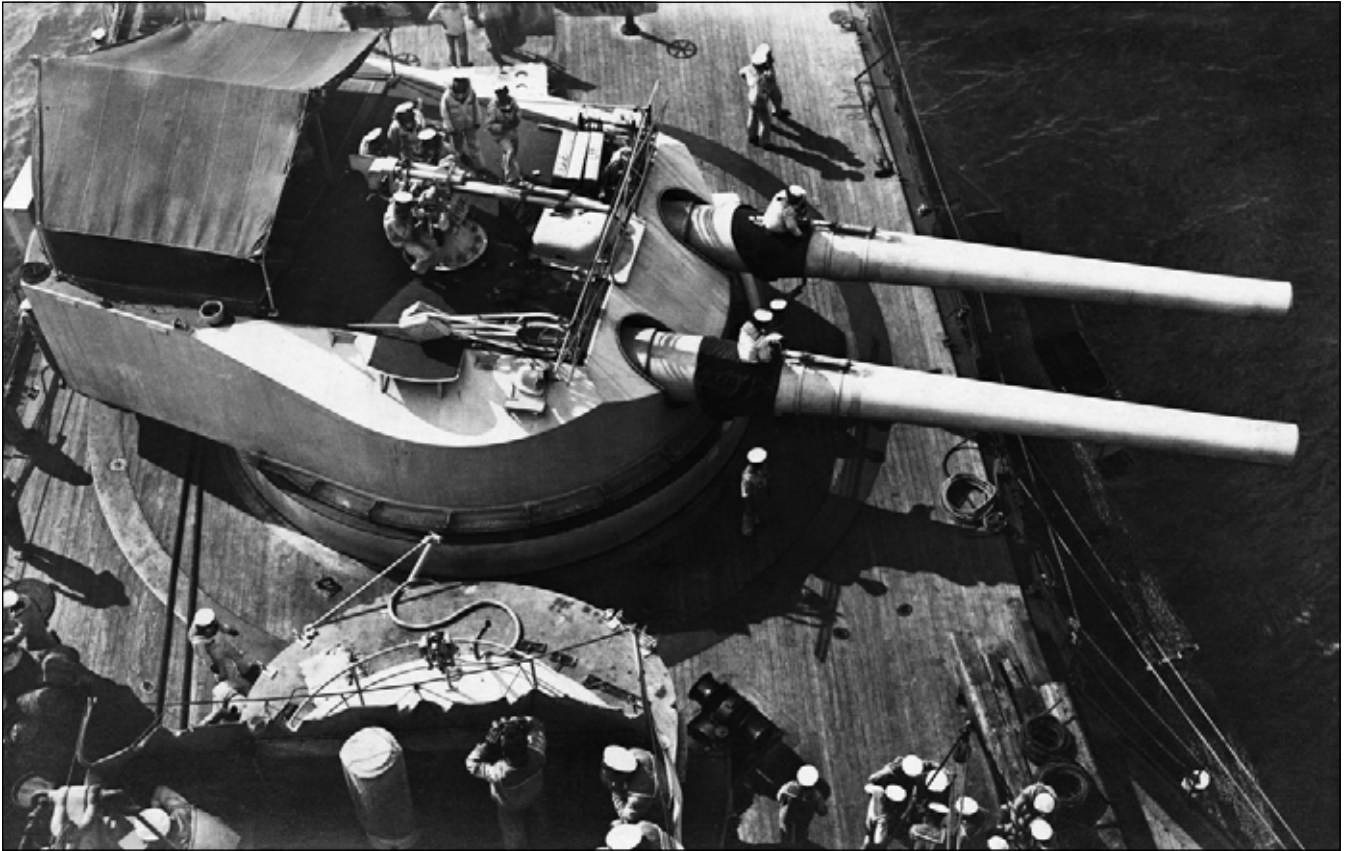

18 30.5 cm twin turret on a Radetzky class battleship. Note the 7 cm/50 AA gun on the turret roof and the metal plates on the deck around the barbette which protected the teak planking from the ejected cartridges

an battleships built with a torpedo protection system, designed by Popper on the basis of purely theoretical calculations. A 54 mm (27+27 mm) thick torpedo bulkhead ran from the forward to the aft 30.5 barbette. The distance between the side shell plating and the torpedo bulkhead was 1.5-2 m, because the trunks and magazines of the wing turrets enabled no greater distance. This torpedo bulkhead was in fact the reinforced inner plating of the double hull. Due to its limited and insufficient deepness this system offered only the illusion of protection against the underwater threats. The construction of the watertight bulkheads was weak and the watertight doors cut in them weakened them further. Due to the known weakness of the bulkheads they had to store a great quantity of timber on these ships for supporting the bulkheads in the case of flooding.

The units of the *Radetzky* class as with all of the preceding Austro-Hungarian battleships were flushdeckers. They were beamier than the *Erzherzog Karl* class battleships their beam/length ratio was 5.64 while the *Erzherzog Karl's* was 5.78. The lack of the raised forecastle deck and the relative

low freeboard made them wet ships and their sea-keeping abilities were also not the best. The relatively large number of crews compared to the ship's size and the lack of the raised forecastle made the crew compartments very cramped, which was a common problem on every Austro-Hungarian battleship. The ships had two pole masts and there was an auxiliary fire control position on the foretop.

The battleships of the *Radetzky* class were the last Austro-Hungarian battleships built with reciprocating steam engines and the first ones with auxiliary oil firing. The weight of the machinery complex was 1300 tons.⁶⁹ The machinery consisted of two four-cylinder vertical triple expansion reciprocating steam engines and twelve coal firing Yarrow water tube boilers with oil spraying. Each steam engine drove a three bladed manganese bronze screw of 5220 mm diameter. Each steam engine had its own machinery room the two rooms were separated by a longitudinal watertight bulkhead. The design power output of the machinery was 20,000 SHP and the design speed of the ships was 20 knots. The twelve boilers were arranged in two boiler rooms, six boilers in two rows in each.

Each boiler room had its own funnel. The transverse watertight bulkhead which divided the two boiler rooms was the most critical bulkhead of the ship because it had the largest surface area and watertight doors were cut in it which further weakened its structure. The ships could carry 1600 tons of coal and 150 tons of fuel oil which enabled a maximum range of 5200 nautical miles at a cruising speed of 10 knots. The ships could carry 1360 tons of briquettes⁷⁰ instead of coal. When using briquette the maximum range dropped to 4300 nautical miles.

The Project of the Fourth Armored Cruiser

From the mid-1890s starting with the *Monarch* class coast defense ships the Austro-Hungarian Navy built an armored cruiser in addition to each battleship (Panzerschiff) class, so Austria-Hungary followed the 3+1 building scheme, while Germany followed the 2+1 scheme. The first Austro-Hungarian armored cruiser was the 5,200 ton *Kaiserin und Königin Maria Theresia* which was built prior to the *Monarch* class. She would have been originally the third unit of a class of three 4,000 ton unarmored cruisers, but her design was modified and her displacement was enlarged. The second armored cruiser was the 6,300 ton *Kaiser Karl VI*. She was built together with the *Habsburg* class. The third armored cruiser was the 7,400 ton *Sankt Georg*, the “fast wing” of the *Erzherzog Karl* class. In the case of the last two ships their design were made by the same boards at the same time as the design of their respective battleship classes.⁷¹ The new armored cruiser, officially designated as *Rammkreuzer F* (ram cruiser)⁷² would have been the companion of the *Schlachtschiff I-III* class. As in the case of the two preceding armored cruisers the design works of the fourth armored cruiser were made by the same boards and at the same time as the works of the new battleship class.

Being not a colonial power and possessing a relatively small merchant fleet,⁷³ Austria-Hungary had only three armored cruisers, while Italy, which had colonial ambitions in North Africa, had ten. Austro-Hungarian armored cruisers had the same caliber main guns (24 cm) as their battleship companions and had the thickest possible armor protection. It is clearly visible that they were intended

to be used in the battle line instead of being protectors of trade or commerce raiders. Their main wartime purpose was to complete the numerically inferior battleship squadrons forming a “fast wing” of the battle line. In peacetime they executed diplomatic missions.

The original specifications for the fourth Austro-Hungarian armored cruiser were 8,000 tons displacement and 23 knots design speed. The design speed of the preceding armored cruiser, *Sankt Georg* was 21 knots. At the board meeting held on 25 September 1905 Kontreadmiral Ripper proposed a uniform armament of twelve 19 cm/45 guns. He said that in contrast to the *Sankt Georg* the new ship had to have a symmetrical armament and the weight of the armament could not exceed the weight of the *Sankt Georg's* considering the design speed of 23 knots. Popper remarked that this armament would have been too heavy considering the desired speed.⁷⁴ At the meeting of 29 September Popper presented five alternative designs:

The Armament of the Popper-designs⁷⁵ (t=in turret, c=in casemate)

A	4×2-19cm t
B	2×1-24 cm t, 6×19 cm c
C	2×1-28 cm t, 4×19 cm c
D	2×1-30,5 cm t, 4×19 c
E	2×2-19 cm t, 6×19 cm c

According to Popper's calculations the displacements of these variant were between 8,500 and 9,000 tons. The displacement of variant D with torpedo bulkheads and 10.5 cm anti-torpedo boat battery would have exceeded 10,000 tons.⁷⁶

Jedlička supported the variant B saying that 19 cm guns were useless against a ship with similar armor. Linienschiffskapitän Baselli supported the A variant with 10.5 cm anti-torpedo boat battery. Linienschiffskapitän Ziegler argued that only a wealthy navy could allow itself to build pure cruisers. A small navy on limited budget like the Austro-Hungarian had to use in the battle line their armored cruisers as the Japanese had done in 1904-1905. So he supported the variant B with 10.5 cm guns and torpedo bulkheads. Popper warned that

the displacement of this ship would exceed 9,500 tons. The admirals, Ripper and Mauler voted for the uniform 19 cm armament.⁷⁷

At the board meeting of 3 November 1905 Li-nienschiffskapitän von Schwarz proposed a 28 cm main battery. Kontreadmiral Kailer supported the variant B with two more 19 cm guns. There was no formal decision on the armament of the armored cruiser at this meeting,⁷⁸ and no other documents related to the design of the *Rammkreuzer F* are found in the Kriegsarchiv Vienna.

Very little is known about the fate of the project of the fourth Austro-Hungarian armored cruiser. On the exemplar of the fleet plan of summer 1905 found in the Kriegsarchiv the displacement of the armored cruiser was modified by hand from 8,000 to 10,000 tons.⁷⁹ The armored cruiser was cancelled during 1906. The budget proposals for 1907 presented to the delegations at the end of 1906 contained only the three 14,500 ton battleships and the *Kreuzer F*, a 3,500 ton scout cruiser, the first steam turbine powered vessel of the Austro-Hungarian Navy. A document written in 1908 contains a reference to the fate of the armored cruiser: she lost her importance thanks to the bad financial situation of the Navy.⁸⁰

There is an interesting and not widely known episode related to the projected armored cruiser. When Marinekommandant Admiral Spaun resigned in 1904 thus protesting against budgetary restrictions the respectful Emperor Franz Joseph ordered on 5 October 1904 to name the Navy's next ship after Spaun. Originally the vessel named after the resigned Marinekommandant would have been the projected armored cruiser. In March 1908, well after the cancellation of the armored cruiser Montecuccoli proposed the Emperor to name the *Kreuzer F* under construction in Pola after Spaun. The Emperor accepted Montecuccoli's proposal.⁸¹ SMS *Admiral Spaun* launched in October 1909 was the first turbine powered light cruiser of the Austro-Hungarian Navy.

Financial and Political Background

As it was mentioned, the extraordinary credit of 120 million Kronen voted for the Navy in 1904 allowed only the acceleration of the construction of the *Erzherzog Karl* class battleships. The credit

also provided a figure of 34 million Kronen for the long time needed building of new destroyers and torpedo boats (*Huszár* and *Kaiman* classes). After the resignation of Spaun in October 1904 the new Marinekommandant, Admiral Rudolf von Montecuccoli had the task of providing the funding for the new battleships.

To pave the way for the new battleships, Montecuccoli presented a memorandum with his fleet program to the Emperor in the summer of 1905. The Marinekommandant named Italy the main enemy of the Dual Monarchy. He envisioned a certain future Austro-Hungarian defeat at the sea if the replacement of the obsolete capital ships would not have been done. Montecuccoli wrote that Italy enjoyed a 2.5-fold superiority in battleships and 3.5-fold superiority in destroyers and torpedo boats over Austria-Hungary, and the Italian naval budget was twice as big as the Austro-Hungarian. He stated furthermore, that the Navy in its existing state was weaker than in the time of the Battle of Lissa and was only able to defend its ports; but he warned not doing that pointing out to the fate of the Russian fleet at Port Arthur. Montecuccoli listed other arguments for the long-term development of the Navy: growing overseas interests and the need of keeping the great power status of the Dual Monarchy.⁸²

The memorandum contained a fleet program of twelve battleships, four armored cruisers, eight smaller cruisers, eighteen destroyers, thirty-six seagoing torpedo boats, forty-eight coastal torpedo boats and six submarines. In the text of the memorandum written by typewriter the displacements of the new battleships, armored cruiser and cruiser were modified by hand, from 13,000 to 14,000 tons, from 8,000 to 10,000 tons and from 3,000 to 3,500 tons. The program prescribed that no battleship could be older than twenty years. Montecuccoli made clear that in the next four years they should build the new battleship class to replace the old casemate ship *Tegetthoff* (1878) and the turret ships *Kronprinz Rudolf* and *Kronprinzessin Stephanie* (1887). The Marinekommandant asked 30.7 million Kronen for 1907 to start the construction of the new battleships.⁸³ The total cost of the three battleships was 118 million Kronen.

Unfortunately for the Navy the delegations could not meet in 1905 due to the Hungarian political crisis. The unified opposition won the 1905

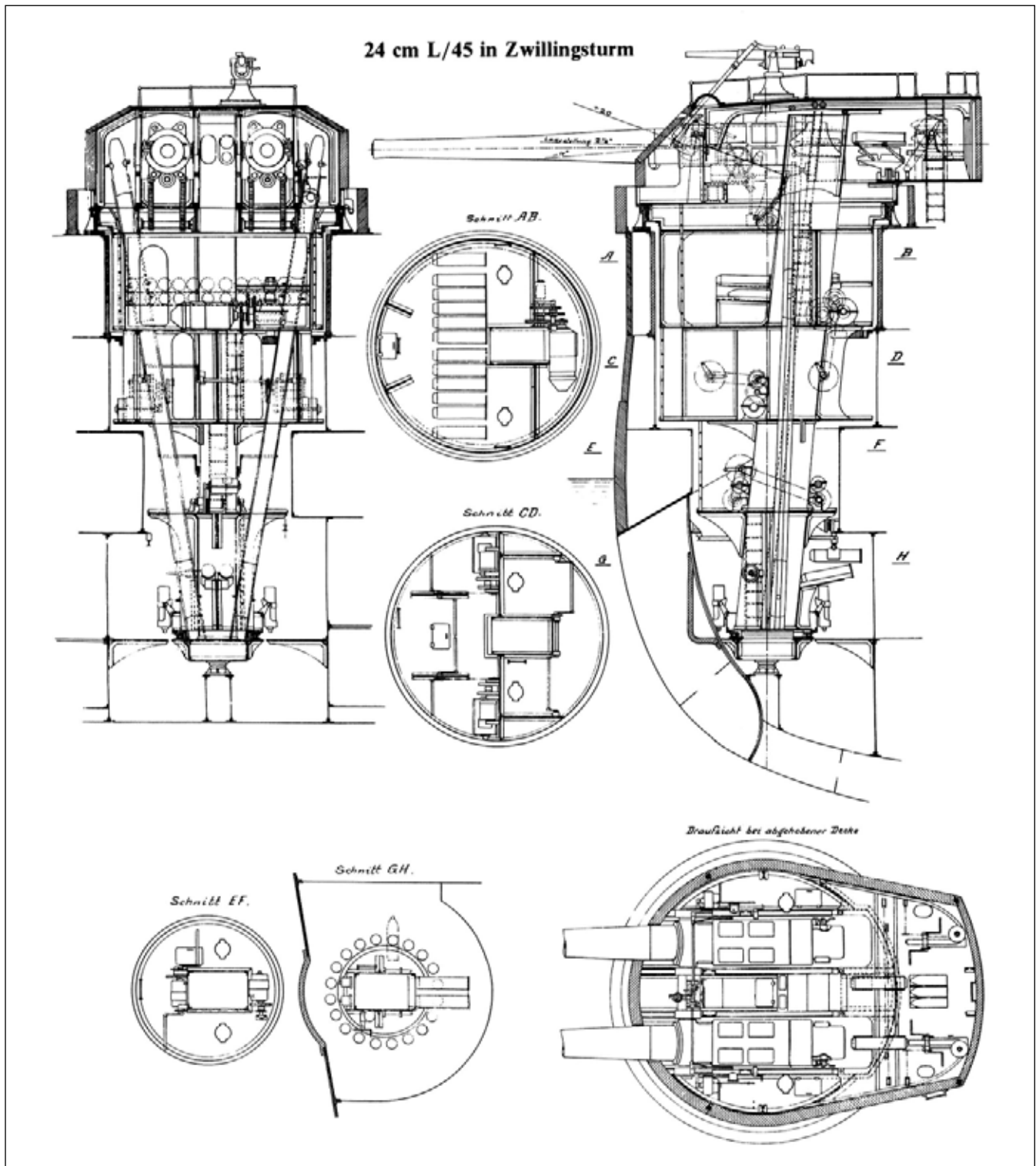

19 24 cm/45 gun turret. Note the so called Gepanzerte Minenboden, the torpedo bulkhead which is the 54 mm thick inner plating of the double side

elections in Hungary, profiting from the unpopularity of Prime Minister Count István Tisza and the negative effects of the so called handkerchief voting (zsebkendőszavazás)⁸⁴ on the governing Szabadelvű Párt (Liberal Party). Because the idea of a government formed by the Függetlenségi és 48-as Párt (Independence and 48 Party) was un-

acceptable for Franz Joseph he appointed General Géza Fejérváry to prime minister. The parliamentary majority declared that the Fejérváry government was unconstitutional and organized a national opposition against it. In April 1906 finally Franz Joseph reconciled with the coalition and appointed Sándor Wekerle to prime minister.

After the reconciliation of Franz Joseph with the Hungarian coalition in April 1906, in June and July the delegations voted for the budgets of 1905 and 1906. On 4 July 1906, the Slovene Ivan Šusteršič member of the Austrian delegation demanded that Austria-Hungary should dominate the Adriatic and should execute the fifteen battleships program of Tegetthoff.⁸⁵ At the next session of the delegations in December 1906 and January 1907 they discussed the budget proposals for 1907. Montecuccoli feared that the new Hungarian coalition government (the former opposition) led by Prime Minister Sándor Wekerle would reject the new battleships. But his fears were baseless the new Hungarian government was content with the April 1906 corroboration of the 1904 agreement on sharing the industrial orders of the Navy. On 21 December 1906, the Hungarian delegation after a short debate on the industrial orders of the Navy voted the expenses of the three battleships, the 3,500 ton cruiser and the new floating dock of 22,000 tons lifting capacity. Only one member of the Hungarian delegation, Count Miklós Zichy voted against the Navy's budget.⁸⁶

The Austrian delegation voted for the battleships on 7 January 1907. During the debate some delegation members blamed the high Austro-Hungarian steel prices. The Hungarian wish to give a Hungarian name to one of the battleships caused great hue and cry in the Austrian delegation. Delegation member Leopold Steiner criticized Montecuccoli's pro-Hungarian policy saying: "... we shall come to see that on a fine day one of the Navy's ship will be named *Kossuth!*"⁸⁷

The *Radetzky* class was the last Austro-Hungarian battleship class consisting of three units and the last which was built from the ordinary budget of the Navy. The expenses of the next battleship classes were now covered from so called extraordinary credits. To secure these extraordinary credits the Navy needed much more struggle with the politicians, especially with the Hungarian ones. So the *Radetzky*s were the last battleships which were built by the "easy" way.

The Construction of the *Radetzky* Class

Immediately after that both delegations voted for the new battleships the Navy started the prepara-

tory works for the construction. The Navy signed the contracts with the main suppliers: the Stabilimento Tecnico Triestino (STT) shipyard in Trieste (hull and machinery), the Witkowitz Ironworks in Witkowitz (armor plates) and Škoda Works in Pilsen (guns and gun turrets). The first orders for steel material was given in February 1907 and in August 1907 all the steel material needed for the *Schlachtschiff I* was gathered in Trieste. As the material transports from the subcontractors arrived the shipyard started to prepare one of the two great slipways for the keel laying.⁸⁸

On 12 September 1907, the keel of the *Schlachtschiff I* was laid down in Trieste. Two and half months later, on 26 November 1907 the keel of the *Schlachtschiff II* was laid down on the second great slipway of the shipyard. Because the STT had only two large slipways, laying down the keel of the third battleship was only possible after the launch of one of the battleships. From October 1907 to July 1908, the STT increased the number of the workers from 919 to 1945 in the San Marco yard where the battleships were under construction. The STT planned further increases but the lack of skilled workers made it impossible.⁸⁹ The STT focused on the building of the first unit of the class and succeeded to break the fourteen month record of the previous class: the much bigger *Schlachtschiff I* was launched after twelve and a half months on 30 September 1908. On 27 February 1908, Montecuccoli said before the Austrian delegation that the new battleships were the strongest in the Mediterranean.⁹⁰ This statement was not true because the French *Dantons* which were larger and more powerful were also under construction.

In Austria-Hungary, the procedure of choosing the name for a new warship usually started a few months prior to the launch. At that time, this procedure was regulated by a regulation sanctioned by the Emperor in May 1898. The Emperor had the right to approve the proposals of the Navy, but on rare occasions he made his own proposals. The first proposal written by the Präsidialkanzlei (Naval Chancellery) was presented to the Military Chancellery of Franz Joseph (MKSM) in February 1908. This memorandum included name proposals for the three battleships,⁹¹ for the *Kreuzer F* and for the six destroyers and ten torpedo boats under construction in Fiume. The writer of the memorandum also mentioned the long standing Hun-

garian wish for giving a Hungarian name to one of the battleships.⁹² The memorandum made the following proposal for the battleships: I *Radetzky*, II *Hunyadi*, III *Prinz Eugen*. This original proposal was modified by handwriting in the document to: I *Radetzky*, II *Prinz Eugen*, III *Zrínyi*.⁹³

One month later on 24 March 1908, Montecucoli presented a new proposal to the Military Chancellery of Franz Joseph. With a clever tactical move the Marinekommandant proposed to name the first unit of the class after the Heir of the Throne *Erzherzog Franz Ferdinand*. Montecucoli supported his proposal with the following arguments: Franz Ferdinand was on the top of the Navy list, he was the great supporter and patron of the Navy, so it would be a great honor to the Navy if its newest and most powerful battleship would bear the name of the Heir of the Throne. For the second and for the third units of the class he proposed the names *Radetzky* and *Zrínyi*.⁹⁴ On 31 March 1908, Franz Joseph approved the proposal.⁹⁵ Despite the first unit being named after the Heir of the Throne contrary to the earlier habit of the Navy, the class was officially named after its second unit (*Radetzky* class, Typ *Radetzky* in the original documents) for an unknown reason.

Undoubtedly, naming the first battleship of the class after the Heir of the Throne was a clever move. The bond between the Navy and the Arch-

duke became even stronger. Franz Ferdinand was very glad when Franz Joseph approved the Navy's proposal naming a battleship after him. When the Emperor approved the name proposal Montecucoli sent a telegram to the Heir of the Throne in which informed him about the approval and added: "The whole Navy is pervaded by the deep sense of gratitude that in a few months its most excellent ship will bear the name of your Royal Highness, our most Honorable Patron." On 4 April 1908, Franz Ferdinand sent a telegram from his castle of Konopište to Montecucoli in which he expressed his gratitude and wrote: "... my whole heart beats for the Navy."⁹⁶ Franz Ferdinand's joy was even greater when the Emperor allowed to hismorganatic wife Princess Sophie von Hohenberg (Chotek) to be the sponsor (Taufpatin), while officially the sponsor of a battleship could only be an archduchess of the Habsburg family. Eventually, the sponsor of the *Schlachtschiff I* was Archduchess Maria Annunziata, the daughter of Franz Ferdinand's stepmother, Archduchess Maria Theresa,⁹⁷ because Princess Sophie was in the last weeks of pregnancy.

The launch of the *Erzherzog Franz Ferdinand* caused panic in Rome because the Italians had nothing comparable. Upon the completion of the 14,500 ton battleships, the Dual Monarchy arguably would enjoy a material naval advantage over

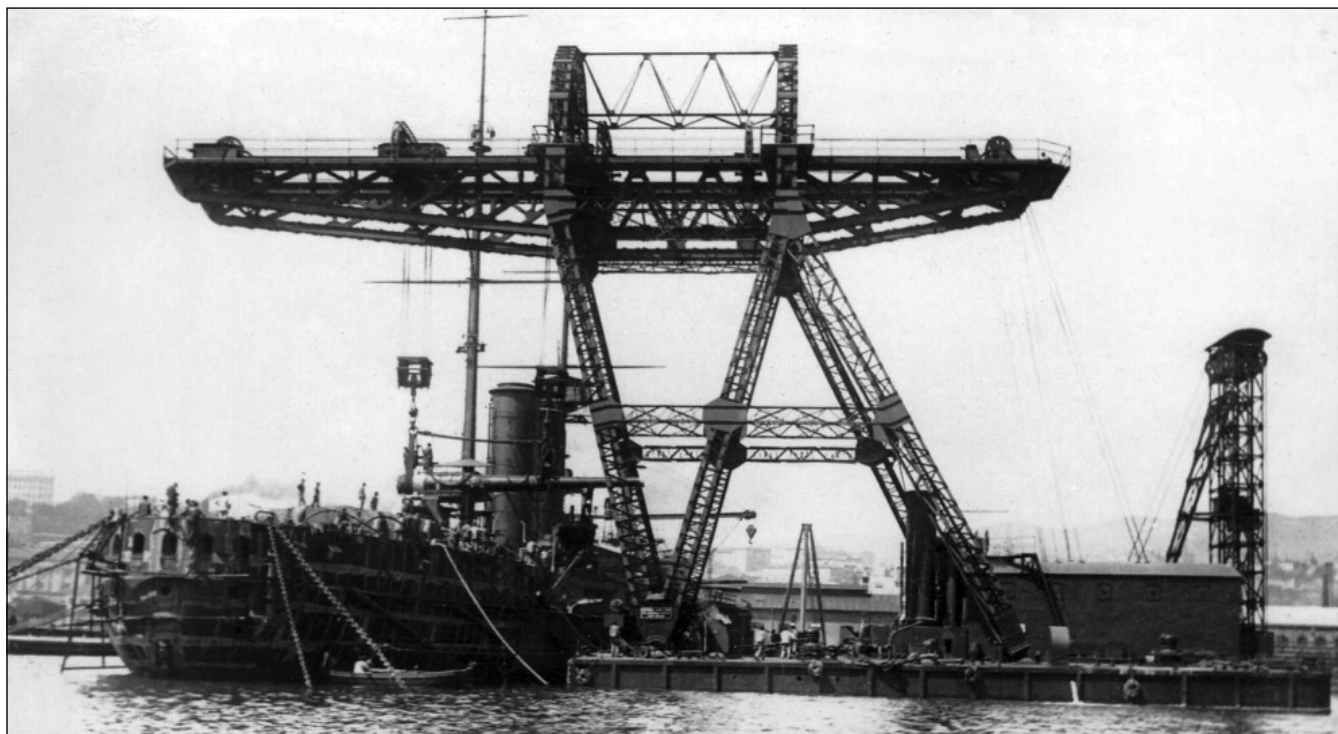

20 *Zrínyi* getting one of her 30.5 cm/45 guns installed

Italy for the first time since the 1870s. While the budget of the Italian Navy for the fiscal year 1907-1908 included a modest sum to start a dreadnought program, little was done before the Bosnian Crisis. At the end of 1908, panicky Italian admirals called for a twofold superiority over the Austro-Hungarian Navy. The Italian government for financial reasons rejected this goal.⁹⁸ The Italians had to recognize that such a ratio of material superiority which the Italian Navy had been enjoyed over the Austro-Hungarian Navy before would be unsustainable in the future. It had been easy to maintain it in the past when the budget of the Austro-Hungarian Navy had not reached 10 percent of the total budget of the Habsburg armed forces. When the Austro-Hungarian Navy's budget began to rise steeply after 1904, Italy's economic and fiscal state did not allow for a similar increase of the naval budget.

The construction of the *Schlachtschiff II* was much slower, partly due to the lack of steel material, partly because the STT focused on *Schlachtschiff I* and the greater part of the workers worked on her. In the summer of 1908 only 63 percent of the material needed for the second battleship was delivered.⁹⁹ On 29 September 1908, Kontreadmiral Chemlarž, the commander of District of Trieste reported to the Marinesektion that the works on the second battleship had stopped because the greater part of the material ordered in Hungary had not been delivered in time and the STT was planning dismissals.¹⁰⁰

On 3 October 1908, Chemlarž sent to the Marinesektion a detailed report on the material orders. On the basis of the agreement between the Hungarian government and the Navy renewed in 1906 the STT as an Austrian shipyard had to order one third of the steel material from Hungarian ironworks as a compensation¹⁰¹ for the Hungarian industry. In the case of the *Schlachtschiff I*, 14 percent of the orders went to the Hungarian ironworks while in the case of the *Schlachtschiff II*, this proportion reached 35 percent. Hungarian ironworks delivered the ordered material with enormous, seven to ten months delays.¹⁰² The second battleship, the *Radetzky* was launched on 3 July 1909; nineteen months after her keel had been laid down. The keel of the third battleship was laid down on 20 January 1909. In her case, 30 percent of the steel material was ordered from Hungarian ironworks.¹⁰³ The last battleship of the class, the *Zrínyi* was launched on 12 April 1910.

The new flagship of the fleet the *Erzherzog Franz Ferdinand* was commissioned on 15 July 1910. Her construction was somewhat slowed by an accident: returning to Trieste from the mandatory docking after the launch in a strong gale slipped her moorings and ran aground. Eighty damaged plates of her underwater hull had to be replaced. On her trials her machinery produced 20,600 SHP and she attained a maximum speed of 20.58 knots. The *Radetzky* was commissioned on 15 January 1911. On her trials her machinery produced 19,437 SHP and she attained a maximum speed of 20.16 knots. The *Zrínyi* was commissioned on 15 September 1911. On her trials her machinery produced 20,000 SHP and she attained a maximum speed of 20.97 knots. With this speed she was the fastest Austro-Hungarian battleship of all times. An interesting fact: despite their obsolete reciprocating steam engines the battleships of the *Radetzky* class were somewhat faster than their successors fitted with steam turbines.

The three units of the *Radetzky* class were not entirely identical. The most apparent visible difference between them was the differing position of their two large boat cranes. For example *Erzherzog Franz Ferdinand's* starboard crane was pointing to the bow while her port crane was pointing to the stern. Each of the three battleships was fitted in 1915 with six 7 cm/50 AA guns (BAG – Ballonabwehr Geschütz) which were mounted on the 30.5 cm and 24 cm turret roofs. During the war, like on the dreadnoughts the three part metal lids of the 30.5 cm and 24 cm gun turret's gunports were substituted with blast bags. In 1917 the torpedo nets and their booms were removed from the *Radetzky's*. This was done because German experiences of the Battle of Jutland/Skagerrak showed that a hit on the net could detach it which posed a threat to the screws. On the evidence of wartime photographs, these ships were not fitted with bomb nets over their funnel caps, these were provided only for the *Tegetthoffs*.

Prior to the outbreak of the war the Austro-Hungarian battleships were painted in the so called "Montecuccoligrün" (Montecuccoli green, olive green) livery. As the primary role intended for the Navy at that time was coastal defense, this livery served to fade into the background of the mountainous Dalmatian coasts. As the naval convention of the Triple Alliance went into ef-

fect in 1913, which envisaged joint operations in the Western Mediterranean, the Navy began in 1914 to repaint their battleships in the so called “Hausblau” (Haus blue, light grey) livery. The light grey color of the new livery was better suited for

the open waters of the Mediterranean. After the outbreak of the war, gun turret and conning tower roofs were painted in dark grey. Until the end of the war the “Hausblau” remained the standard livery of the battleships and smaller units.

Technical Data of the *Radetzky* Class

Length on waterline: 137.45 m
Overall length: 138.78 m
Beam: 24.6 m
Draught: 8.06 m

Displacements

Normal or trial: 14,508 metric tons
Full load: 15,854.5 metric tons

Machinery

12 coal fired Yarrow water tube boilers with oil spraying, 4296 m² heat transfer surface area
Boilers in two boiler rooms, two funnels
2 four cylinders triple expansion vertical reciprocating steam engines on two shafts
Steam engines in two machinery rooms divided by a longitudinal watertight bulkhead
Two screws of 5220 mm diameter
Design power: 20,000 SHP
Erzherzog Franz Ferdinand 20,600 SHP 20.58 knots
Radetzky 19,437 SHP 20.16 knots
Zrínyi 20,000 SHP 20.97 knots
Fuel: coal 1,600 tons or briquette 1,360 tons, oil 150 tons
Range: 5,200 nm at 10 knots with coal or 4,300 nm at 10 knots with briquette, 1,500 nm at 20 knots with coal or 1,250 nm at 20 knots with briquette

Armor

(KC: Krupp cemented, K: Krupp non-cemented, SM: Siemens-Martin)
Belt: 230 mm KC, lower part tapered to 180 mm KC
Upper belt: 150 mm KC
Casemate: 120 mm KC
Bow/stern: 100/100 mm KC
Fore and aft armored bulkheads: 150 mm KC
Fore conning tower/roof: 250 mm KC/60 mm K
Aft conning tower/roof: 120 mm KC/40 mm K

30.5 cm barbets: 250 mm KC
24 cm barbets: 200 mm KC
Armor deck/torpedo bulkhead: 48-36/54 mm SM
30.5 cm gun turrets face/side/inclined part/roof: 250/250/150 mm KC/60 mm K
24 cm gun turrets face/side/inclined part/roof: 200/200/120 mm KC/50 mm K

Armament

4×30.5 cm/45 Škoda guns with sliding wedge breech (Krupp-system)
Weight of the gun turrets 439 metric tons
Weight of barrel with breech: 54.63 metric tons
Elevation: -4°/+20°
Elevation/train rate: 3° per sec/3° per sec
Allowance for each gun: 75
Projectile's weight: 450 kg
Muzzle velocity: 800 mps
Rate of fire: 1-2 rounds per minute
Range: N/A (Estimated range 18,500 m at +20°)

8×24 cm/45 Škoda guns with sliding wedge breech (Krupp-system)
Weight of the gun turrets: 238.8 metric tons
Weight of barrel without breech: 26.9 metric tons
Elevation: -4°/+20°
Elevation/train rate: 3° per sec/3° per sec
Allowance for each gun: 100
Projectile's weight: 215 kg
Muzzle velocity: 800 mps
Rate of fire: 2 rounds per minute
Range: N/A (Estimated range 16,500 m at +20°)

20×10 cm/50 Škoda guns with sliding wedge breech in casemates
Weight of barrel: 2020 kg
Elevation: -4°/+15°
Weight of the ammunition: 26.2 kg
Allowance for each gun: 300
Projectile's weight: 14.5 kg
Muzzle velocity: 880 mps

Rate of fire: 15 rounds per minute

Range: 11,000 m

6×7 cm/50 (6.6 cm) Škoda AA guns with sliding wedge breech on central pivots on turret roofs

Weight of a gun with mounting: 2030 kg

Elevation: -5°/+90°

Weight of the ammunition: 8.5 kg

Allowance for each gun: 200

Projectile's weight: 4.5 kg

Muzzle velocity: 830 mps

Rate of fire: 20 rounds per minute

3×45 cm Whitehead submerged torpedo tubes
(1 bow, 1-1 broadsides)

Allowance: 3 torpedoes per tube

Torpedo's weight: 631 kg

Overall length: 5.2 m

Explosive charge: 110 kg

Fire control

2×2743 mm (9 feet) Barr&Strouds rangefinders
on the top of the fore and aft conning towers

2×2743 mm (9 feet) Barr&Strouds rangefinders
on the top of the battery commando post in
the superstructure

6×90 cm searchlights as built

8×110 cm and 2×90 searchlights from 1915

Boats (2×13 ton boats crane)

Erzherzog Franz Ferdinand starboard crane is
pointing to the bow, port crane is pointing to
the stern

Radetzky starboard crane is pointing to the stern,
port crane is pointing to the bow

Zrínyi both cranes are pointing to the bow

1×13 tons steam barge

1×9 tons motor barge

2× barges

3× cutters

1× rescue cutter

3× gigs

6× jolly boats

Complement

30 officers, 846 men

Call signals

Erzherzog Franz Ferdinand: BJ and 60,021

Radetzky: BR and 60,022

Zrínyi: BY and 60,023

Commanders

(Lschk: Linienschiffskapitän)

Erzherzog Franz Ferdinand

Lschk Georg Ritter von Kirchmayr 16 June 1910

Lschk Josef Ritter von Schwarz 13 October 1910

Lschk Oskar Gassenmayr 30 April 1911

Lschk Richard Ritter von Barry 18 October 1911

Lschk Oskar Hansa 20 August 1912

Lschk Hugo Zaccaria 23 April 1913

Lschk Kamillo von Schwarzl 5 March 1914

Lschk Ferdinand Ritter von Purschka 19 June
1917 – 15 February 1918

Lschk Heinrich Freiherr Pergler von Perglas 10
March 1918 – 14 April 1918

N/A

Radetzky

Lschk Paul Fiedler 11 January 1911

Lschk Maximus Freiherr von Hauser 20 October
1911

Lschk Franz Ritter von Keil 8 January 1912

Lschk Franz Löffler 3 May 1912

Lschk Gottfried Freiherr Meyern von Hohenberg
3 September 1912

Lschk Kamillo Teuschl 20 August 1913

Lschk Vitus von Vončina 8 March 1914

Lschk Marius Ratković 2 August 1917 –
13 March 1918

N/A

Zrínyi

Lschk Lino Lius 1 September 1911

Lschk Alfred Freiherr von Koudelka 4 September
1912

Lschk Maximilian Daublebsky von Eichhain
14 August 1913

Lschk Alois Schusterschitz 16 September 1917 –
17 March 1918

N/A

Schlachtkreuzer von 1450 Tonnen Displacement.

„S. 203 S. Typ Kreuzer“

Abbildung 1120

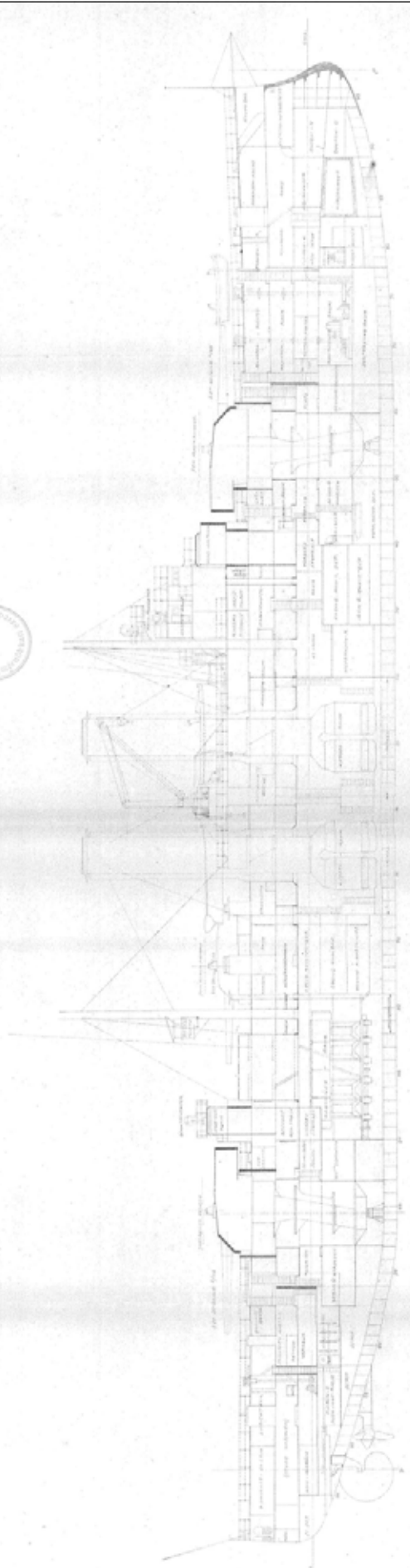

Zusammenfassung
Abbildung 1120

Schlachtkreuzer von 1450 Tonnen Displacement.

„S. 203 S. Typ Kreuzer“

Abbildung 1120

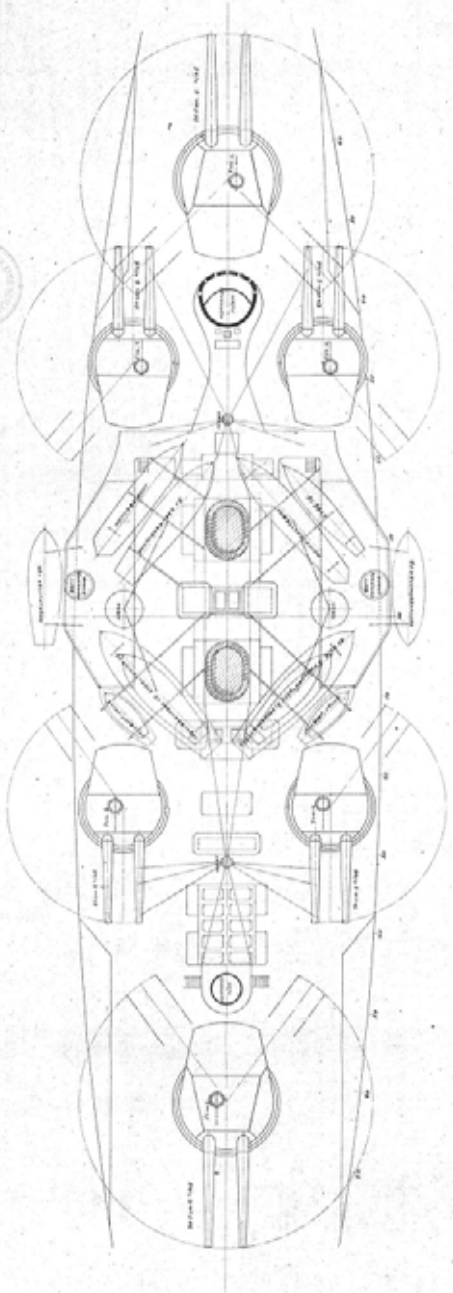

Hinterer Torpedoschiffsschütz

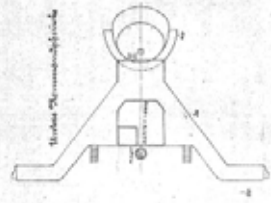

Vorderer Torpedoschiffsschütz

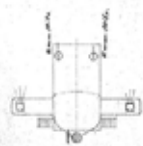

Schiffsbau

Abbildung 1120

Schachtschiff von 14500 Tonnen Displacement.
 „S.M.S. Typ Haderly“

Dr. Ing. Schiffsbauingenieur
 Adolf von Meyer 1878

Schiffsbau



Modelljahr 1878

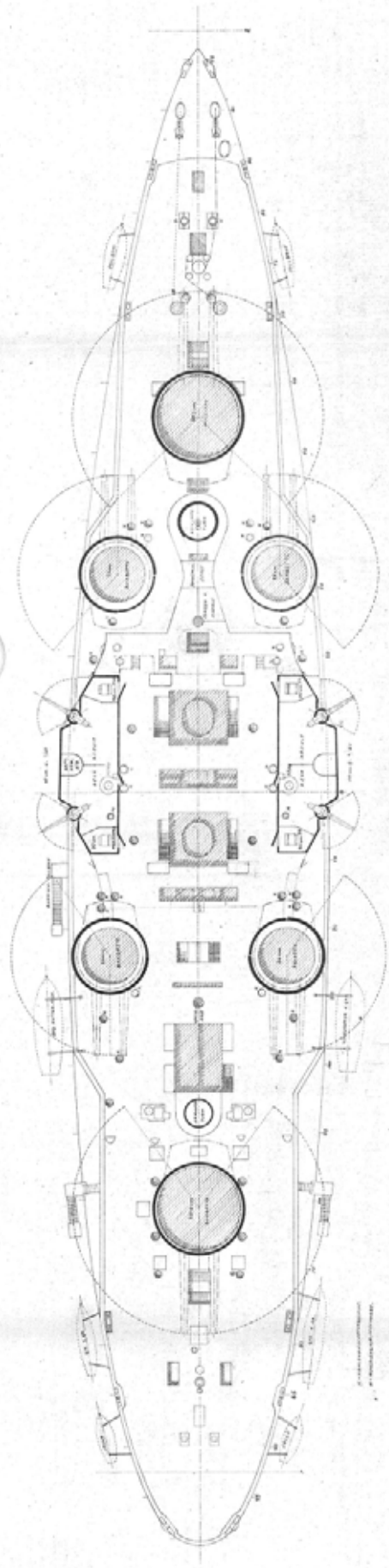

Schachtschiff von 14500 Tonnen Displacement.
 „S.M.S. Typ Haderly“

Dr. Ing. Schiffsbauingenieur
 Adolf von Meyer 1878

Schiffsbau



Modelljahr 1878

Dr. Ing. Schiffsbauingenieur
 Adolf von Meyer 1878

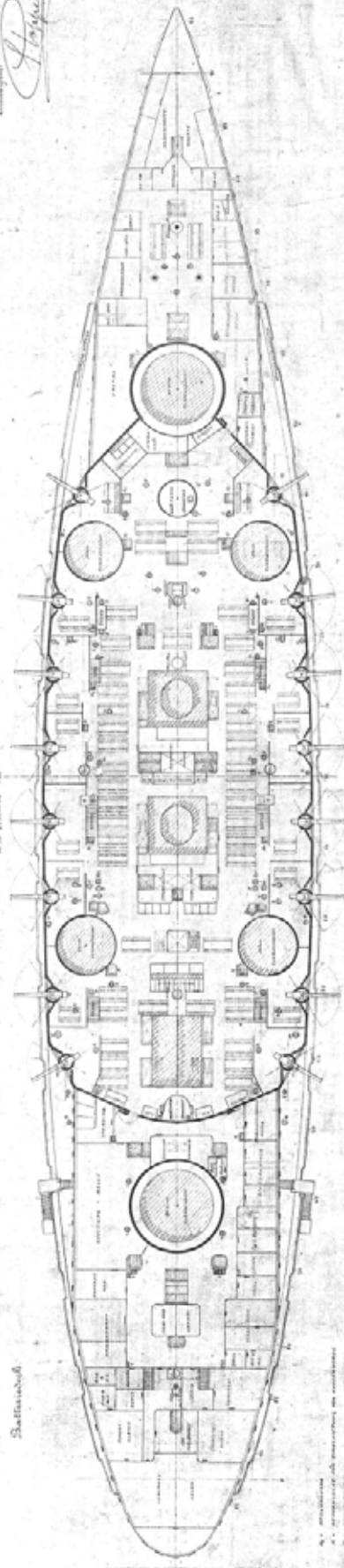

- 1. Hauptgeschütz
- 2. Nebengeschütz
- 3. Torpedorohr
- 4. Wasserrohr
- 5. Wasserpumpe
- 6. Wasserschiff
- 7. Wasserschiff
- 8. Wasserschiff
- 9. Wasserschiff
- 10. Wasserschiff
- 11. Wasserschiff
- 12. Wasserschiff
- 13. Wasserschiff
- 14. Wasserschiff
- 15. Wasserschiff
- 16. Wasserschiff
- 17. Wasserschiff
- 18. Wasserschiff
- 19. Wasserschiff
- 20. Wasserschiff
- 21. Wasserschiff
- 22. Wasserschiff
- 23. Wasserschiff
- 24. Wasserschiff
- 25. Wasserschiff
- 26. Wasserschiff
- 27. Wasserschiff
- 28. Wasserschiff
- 29. Wasserschiff
- 30. Wasserschiff
- 31. Wasserschiff
- 32. Wasserschiff
- 33. Wasserschiff
- 34. Wasserschiff
- 35. Wasserschiff
- 36. Wasserschiff
- 37. Wasserschiff
- 38. Wasserschiff
- 39. Wasserschiff
- 40. Wasserschiff
- 41. Wasserschiff
- 42. Wasserschiff
- 43. Wasserschiff
- 44. Wasserschiff
- 45. Wasserschiff
- 46. Wasserschiff
- 47. Wasserschiff
- 48. Wasserschiff
- 49. Wasserschiff
- 50. Wasserschiff

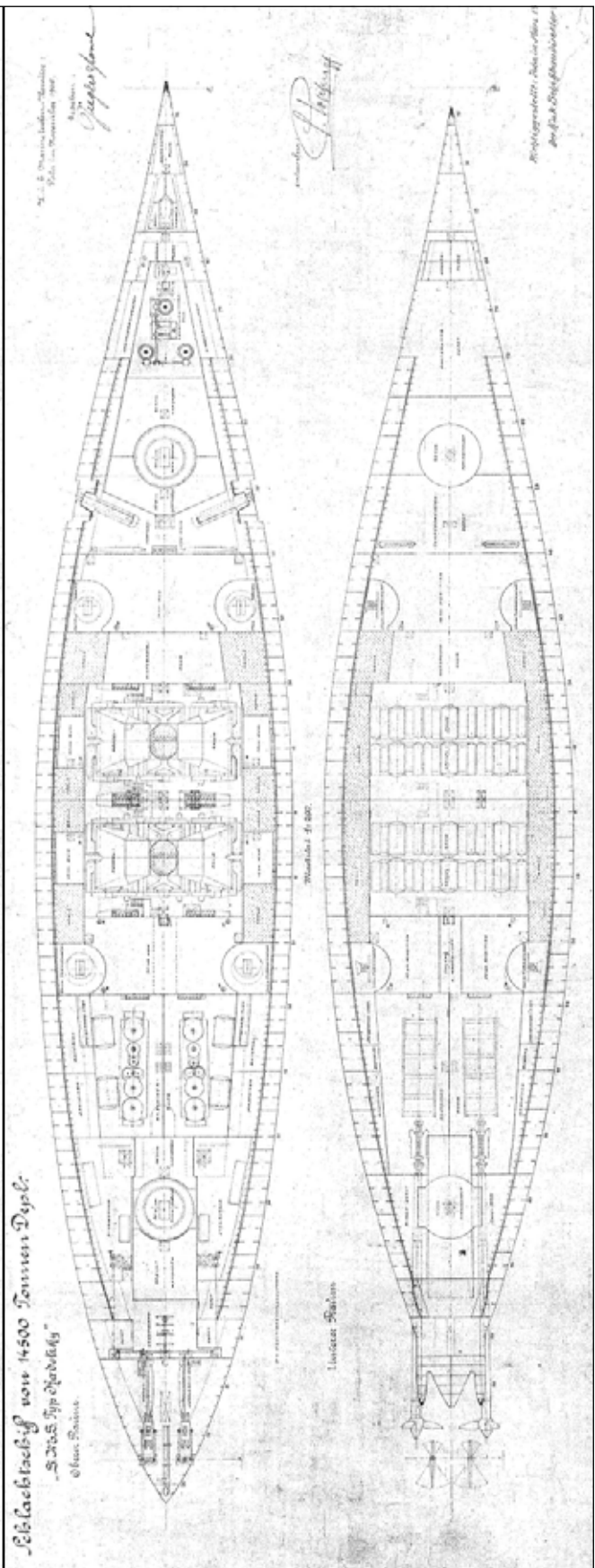
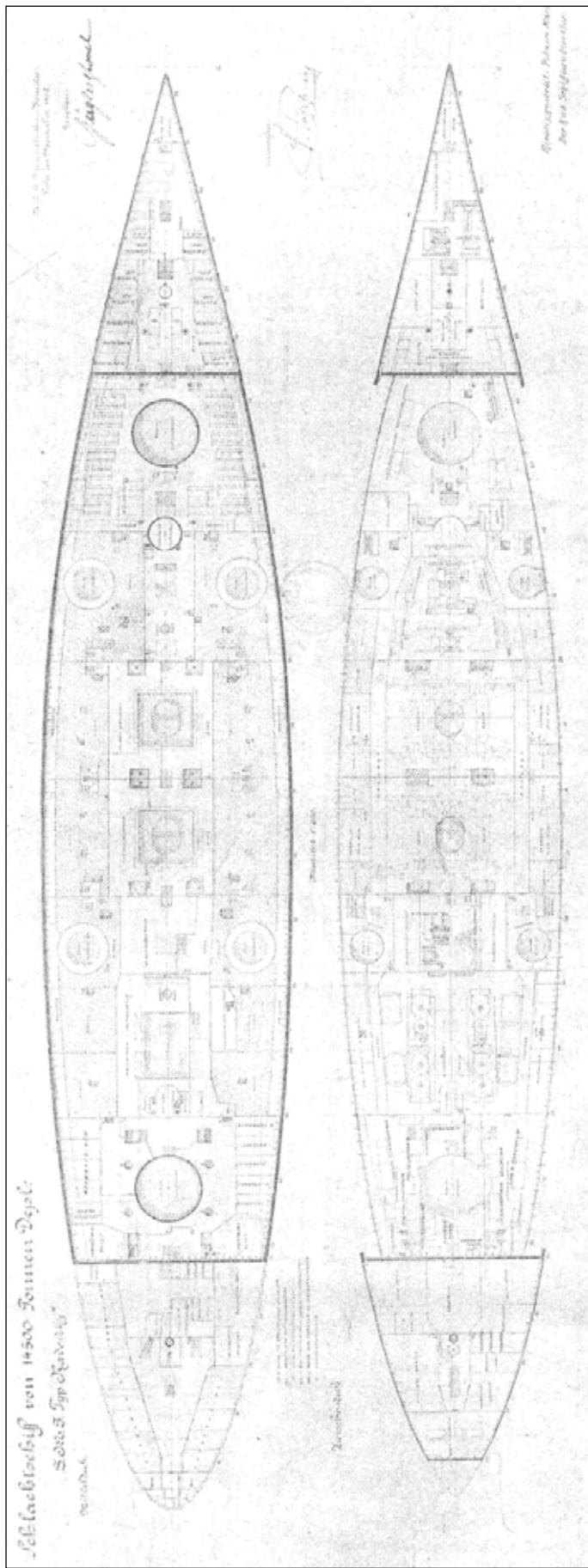

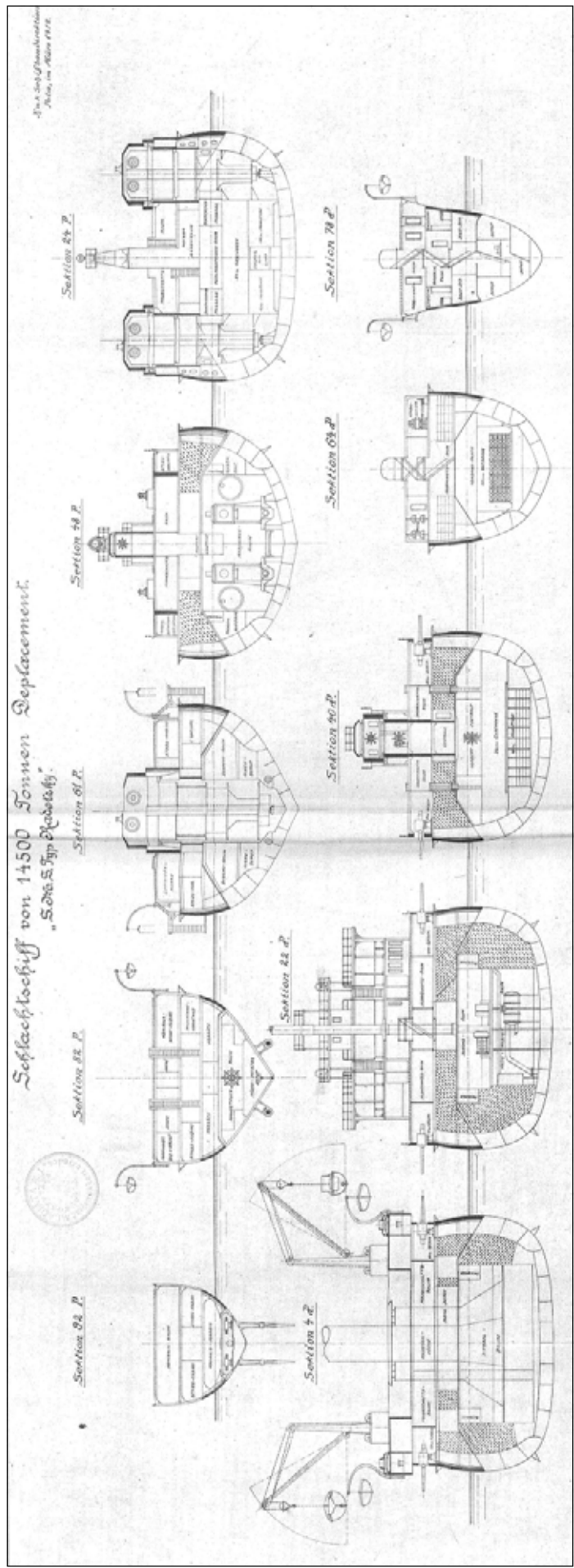

THE FIRST AND LAST DREADNOUGHTS OF THE DUAL MONARCHY THE TEGETTHOFF CLASS

In 1906, after the Austrian and Hungarian delegations voted for the costs of the mixed large caliber battleships of the *Radetzky* class, although in their design phase Montecuccoli had refused the idea of building all big gun battleships, the Navy recognized the urgent need of future dreadnought construction. In the summer of 1906, politics and propaganda started to prepare the way for the true dreadnoughts. In July 1906, Montecuccoli declared before the Austrian delegation that in the future the Monarchy should build 20,000 ton battleships. In February 1908, Montecuccoli presented his voluminous memorandum to the Emperor and to the Austrian and Hungarian governments in which he urged the building of four 18-19,000 ton battleships citing the danger posed by the Italian dreadnought program¹⁰⁴

The mixed large caliber design of the 14,500 ton battleships was not exactly what had been envisaged in 1904 for a qualitative leap in battleship design and construction, at least in the new dreadnought-era. The Dual Monarchy had decided to build true dreadnoughts for two reasons: first, because the eternal rival, Italy planned to build dreadnoughts and second, because the Habsburg Empire had to maintain its great power status. After 1906, one of the most important attributes of the great power status was the possession of dreadnoughts, all the more so because many lesser powers were planning to build or to purchase dreadnought battleships.

The Navy continued the habit that had been started with the preceding class of designating the new designs as *Schlachtschiff* (battleship). The new battleships, designed from the very start as dreadnoughts, were designated as *Schlachtschiff IV-VII*. Besides being the first all big gun battleships of the Austro-Hungarian Navy, they also hold the distinction being first in many other respects. The *Tegetthoff* class was the first Austro-Hungarian class of battleships which had four units instead of three. The *Tegetthoffs* were the first battleships of

the Dual Monarchy powered with steam turbines, the first of which construction's costs were covered by an extraordinary credit instead of the ordinary budget, and the first Austro-Hungarian class of battleships of which units were not exclusively built in an Austrian shipyard: the last unit, the *Szent István*, was built at the Hungarian Ganz and Co, Danubius Shipyard in Fiume. The first unit of the class, the *Viribus Unitis*, holds the honor of being the world's first battleship commissioned with triple turrets. She also holds the dubious honor being the most expensive battleship in the world at the time of her commission, with the cost being about £2.5 m. With the four dreadnoughts of the *Tegetthoff* class, the Austro-Hungarian Monarchy became a full member of the club of the great powers and on the eve of the First World War the Navy became a Mediterranean factor instead of a mere Adriatic coastal defense force.

The 20,000 Ton Design

The design on the next battleship class (*Schlachtschiff IV-VII*) was started on 7 May 1908 at Pola. A board headed by the Marinekommandant, Admiral Rudolf von Montecuccoli discussed the possible armament of the new ships. Some conservative members advocated a ship armed with eight 30.5 cm guns with heavy secondary battery (19 cm), while the others wanted a ship with ten to twelve 30.5 cm guns. Kontreadmiral Lazar Shukić advocated for a battleship armed with twelve heavy guns and with only a light secondary battery. Linienschiffskapitän Emil Fath pleaded for a battleship armed with ten heavy guns and twelve 15 cm guns. Kontreadmiral Anton Haus favored a ship similar to the French *Danton* with six wing turrets, but with four 30.5 cm guns mounted on the central wing turrets and with eight 19 cm guns mounted on the end wing turrets. Kontreadmiral Ziegler proposed a battleship armed with eight

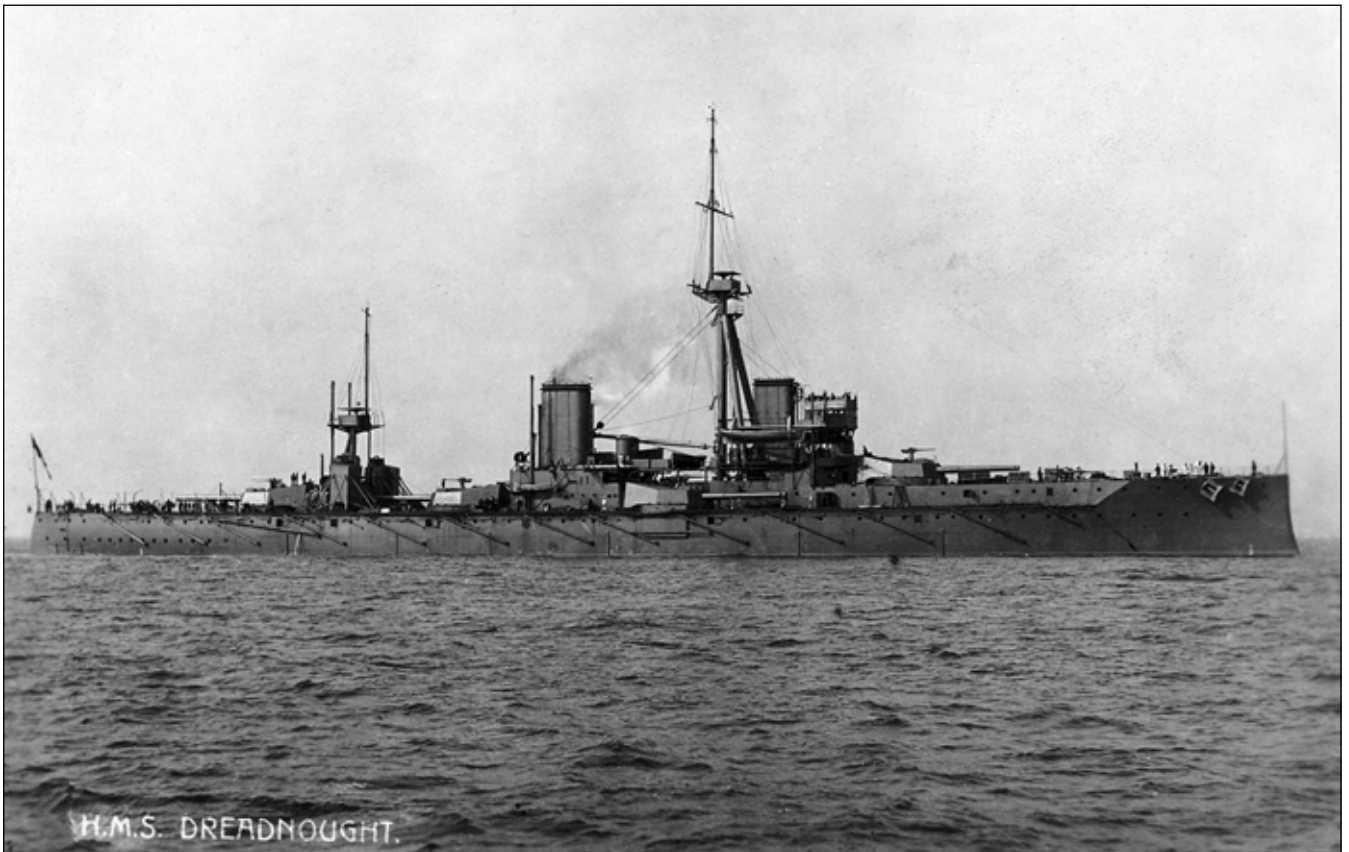

22 HMS Dreadnought, the first "all big gun" battleship

heavy guns mounted on gun turrets all on the centerline and with twelve to sixteen 19 cm guns in wing turrets. Kontreadmiral Jedina pleaded for a battleship with eight heavy guns and sixteen 15 cm guns. Vizeadmiral Julius von Ripper envisaged a battleship armed with eight 30.5 cm guns and with a 19 cm secondary battery in casemates. He called the board's attention to the importance of the watertight compartments because he considered the so called *gepanzerte Minenboden* (torpedo bulkhead as described by Siegfried Popper) to be insufficient as protection against underwater explosions.¹⁰⁵ At the time of the board meeting the 19 cm guns as the secondary battery for battleships were now considered to be anachronistic. They were ineffective against both battleships and fast torpedo boats. Against destroyers and torpedo boats 15 cm guns were considered to be much more effective due to their easier handling and greater rate of fire.

At the end of the meeting Montecuccoli in his closing speech announced that the displacement of the future battleships should not exceed 18,500–19,000 tons so their armament should be limited to eight 30.5 cm and eight 19 cm guns. Oberinge-

nieur Keil supported the use of steam turbines with the proviso that the Austro-Hungarian industry could produce them. He advised not to use mixed firing boilers citing the bad experiences of the Royal Navy. He proposed that instead pure coal firing and pure oil firing boilers should be used.¹⁰⁶ In the same file there is a handwritten piece of paper listing the main specifications for the future battleship which also indicates that the increase of displacement to 20,000 tons occurred shortly after the board meeting.¹⁰⁷

On 24 June 1908, the Navy invited entries for a battleship design competition for the naval architects of the MTK with the following particulars: displacement 20,000 tons maximum, 30.5 cm main battery, 19 cm secondary battery, belt 230 mm thick. On 6 July the MTK reported to the Marinesektion that they had made participation mandatory on every Schiffbauingenieur I Klasse (naval architect of first class rank) to be in the design competition. In many fields (for example, machinery) they had given a free hand to the naval architects. They added that the Maschineingenieure (machinery engineers) of the MTK were inexpe-

rienced in turbine design, and thus could be expected to produce only reciprocating steam engine designs.¹⁰⁸

In October, when the MTK realized that the mandatory participation order badly affected the normal work of the designers, this order was withdrawn. On 5 November the same year the Navy called upon the STT and the Hungarian Danubius (Fiume) shipyards to join the design competition. This was an unprecedented step in the history of the Austro-Hungarian battleship design; previously all designs had been produced by the MTK.¹⁰⁹ The main reason behind this decision was most likely the Navy's intention to familiarize the former Generalschiffbauingenieur, Siegfried Popper in the design of the new battleships. The STT, where the retired Popper was now working as chief advisor, accepted the request on 17 November and asked for sending the design specifications,¹¹⁰ while the Danubius refused it on 24 November. The new Hungarian shipyard cited the undeveloped state of the yard and the lack of great slipways and railway connection.¹¹¹ On 1 January 1909, upon the request of the MTK and the STT, the Navy permitted the designers to use 15 cm or 12 cm guns instead of 19 cm guns as the secondary battery.¹¹²

The MTK presented its design on 2 February 1909. The MTK's presentation was signed by Kontreadmiral Luzian von Ziegler. In reviewing the documents, Montecucoli made some handwrit-

ten comments on it. In one of his comments, the Marinekommandant considered the ship's crew too large. Unfortunately, the fourteen original supplements that were attached to the presentation are missing from the file and so the details of the design are unknown. The MTK design was armed with ten 30.5 cm guns mounted on five twin turrets and fourteen 15 cm guns mounted in casemates, both 30.5 cm and 15 cm guns were of 50 caliber lengths. There were two alternatives given for the belt armor: a narrow 250 mm variant and a taller 230 mm variant. Both variants were the same length. The torpedo bulkhead was 114 m long and 54 mm thick and its spacing from the side shell plating was "the greatest possible". The 25,000 SHP design power machinery consisted of two reciprocating steam engines powered by fifteen boilers.¹¹³

The STT presented seven designs all made by Popper on 5 March 1909. The original designs now are missing from the official files but the summary made by the Navy contains their main technical detail. The STT designs were all powered with steam turbines. STT had purchased a license from Parsons shortly before submitting their designs. The designs with ten guns used 30.5 cm/50 weapons while those with twelve guns used 30.5 cm/45 caliber weapons. (STT V).¹¹⁴ The torpedo protection of these designs was similar to the preceding *Radetzky* class.

The MTK and STT designs¹¹⁵

	Displacement ton	Dimensions m	Armor mm Belt/turret	Power SHP	Main Battery	Secondary Battery	Anti-torpedo boat Battery
MTK	19,700	159×26	230/250	25,000	10×30.5	14×15	11×7
STT I	20,000	151×26	230/250	25,000	8×30.5	10×19	20×10
STT II	20,000	151×26	230/250	25,000	8×30.5	8×19	20×10
STT III	20,000	151×26	230/250	25,000	10×30.5	10×15	14×10
STT IV	20,000	151×26	230/250	25,000	10×30.5	14×12	14×10
STT V	20,000	151×26	230/250	25,000	12×30.5	24×10	-
STT VI	20,000	151×26	230/250	25,000	10×30.5	14×15	11×7
STT VII	20,000	151×26	230/250	25,000	10×30.5	18×12	11×7

On 14 April 1909, the 4th department (ship-building) of the II Geschäftsgruppe of the Marinesektion examined the eight designs. They stated that the design of the MTK actually would have exceeded the 20,000 tons displacement limit by 1,000 tons. On the other hand, they considered that the greater spacing between the gun turrets of the MTK design would provide better arcs of fire. They criticized the secondary battery of the STT IV design (12 cm and 10 cm). The 4th department considered the 230 mm belt armor barely enough for the battleships. They supported the use of steam turbines instead of reciprocating steam engines, referring to the much greater development potential of the former.¹¹⁶ The stand of the 4th department on the steam turbines foreshadowed the defeat of the MTK in the battle for the design of the new battleships against Popper and the STT. The MTK had no experience in the field of steam turbines.¹¹⁷ They tried to gain data about them,¹¹⁸ but the STT which was already in a partnership with the British firm of Parsons, had a great advantage in this field.

The Marinesektion arranged the designs in three groups: the designs with 19 cm secondary battery in the first, the design with twelve heavy guns (STT V) in the second and the rest in the

third. On 15 April, the Navy asked the STT by telephone to redesign the STT V design with different secondary battery. On the next day the shipyard answered in a telegram. Popper was against the design V instead he favored the designs VI or VII. Popper pointed out “if Škoda factory had problems” with the development of the 50 caliber length variant of the 30.5 cm gun, then using the shorter, 45 caliber length version of this gun would make it possible to increase the thickness of the belt armor to 250 mm.¹¹⁹ On the basis of the STT’s answer, on 20 April the Navy asked the STT to work on the design of a battleship with twelve 30.5 cm guns in six twin turrets not exceeding the 20,000 tons displacement limit.¹²⁰ On 27 April, the STT sent to the Navy two design variants: Va and Vb, the first with a secondary battery of eight 15 cm guns and the second with twenty 10 cm guns. The arrangement of the gun turrets of both variants was similar to the Brazilian battleship *Minas Geraes*. The thickness of the belt armor was 230 mm and both of the designs had two tripod masts.¹²¹ In this phase of the design process, Montecuccoli sent his secretary, Fregattenkapitän Alfred von Koudelka to Berlin on a secret mission.



23 The Brazilian battleship *Minas Geraes* which inspired the STT/Popper design No V armed with twelve 30.5 cm/45 guns

The Koudelka-mission

During the design process of the future *Tegetthoff* class, an interesting and unprecedented episode occurred: the Austro-Hungarian Navy asked the permission of its great ally, the German *Kaiserliche Kriegsmarine*, to obtain information about the newest trends in German battleship design. On 17 April 1909, little after the first draft designs of the future dreadnoughts had been completed Montecuccoli sent a letter via the Austro-Hungarian Military Attaché in Berlin, Karl von Bienenreth to Admiral Alfred von Tirpitz, the head of the German Reichsmarineamt, asking his permission for an Austro-Hungarian naval officer to gather information in strict confidence on the new German battleships then under construction.¹²² The Marinekommandant referred to the intention of the k. u. k. Kriegsmarine to build 20,000 ton battleships, and he explained his request with the need for the possible quickest decision on the armament of these battleships.

The permission from Berlin arrived on 25 April 1909. Kaiser Wilhelm II personally gave the permission to the Reichsmarineamt to share confidential information on the newest German battleships with the Austro-Hungarian ally. Montecuccoli chose his secretary, Fregattenkapitän Alfred von Koudelka for the mission. Koudelka left for Berlin on 28 April and arrived back to Vienna on 1 May.

Koudelka was received by Konteradmiral Gustav von Bachmann who introduced him to Tirpitz. Tirpitz made a conversation of two hours with Koudelka, who after leaving the Admiral's office visited the departments of the Reichsmarineamt escorted by Kapitänleutnant Wernher von Rheinbaben, adjutant of Tirpitz.

The British were also interested in the Austro-Hungarian battleship projects, so a British spy followed Koudelka during his visit in Berlin. According to Koudelka, on the morning of 29 April, Tirpitz showed Koudelka the British spy out on the street from the window of his office and asked Koudelka not to wear his uniform.¹²³ On this same day, Tirpitz told Koudelka that the leading principle of the German battleship design was the supremacy of the survivability.¹²⁴ For this reason German battleships had the maximum possible belt armor and a carefully tested underwater protective system. Tirpitz also advocated for retaining the

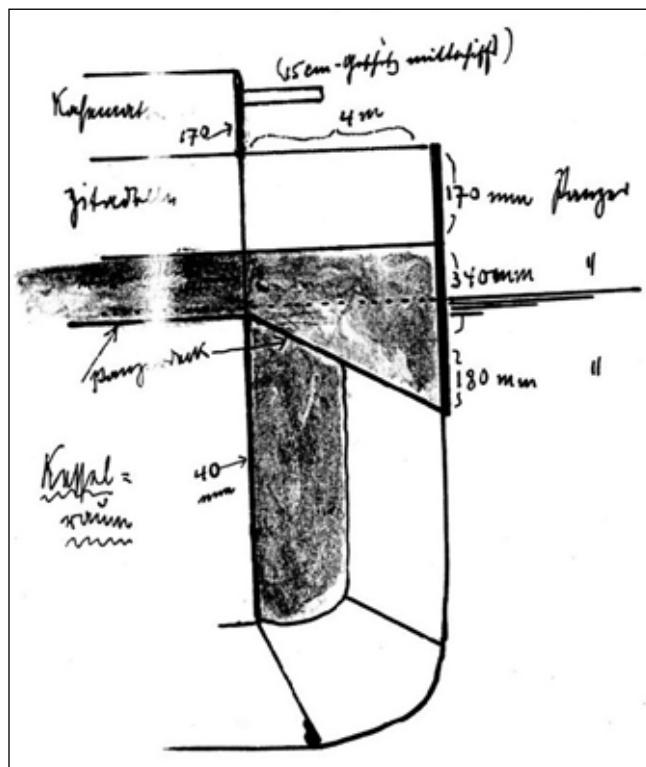

24 Koudelka's sketch of the torpedo protection system of the German Kaiser class

15 cm secondary battery under casemate armor in contrast to British practice which, under the guidance of Admiral Fisher, used smaller calibers.¹²⁵

Koudelka had the opportunity of examining the plans of the German dreadnoughts and even given permission to make some sketches to copy details. On the next day he continued the examination of the battleship plans and Geheimrat Veit showed him the four meters-long cutaway model of the dreadnought *Nassau*.¹²⁶ Before departing to Vienna, Koudelka briefly met Tirpitz again and gratefully thanked him for the precious information that he had been given.¹²⁷

In his secret report Koudelka gave an account of the results of the German gunnery and underwater explosion tests. From 1906, the Germans, who had recognized the importance of survivability as one of the lessons from the Russo-Japanese War, conducted careful and expensive tests. The gunnery tests were carried out on old armored ships and on full scale sections representing the dreadnought *Nassau*, the latter being conducted on the Krupp's artillery test ground of Meppen. They observed that hits on the sections caused flames "as high as a building" as projectiles passed through coal bunkers, pulverizing and igniting coal. In Tirpitz's view

this phenomenon had been responsible for the uncontrollable fires on the Russian ships at the Battle of Tsushima when burning coal dust had ignited the flammable paints used by the Russians. These results inspired the Germans to make a study of the flammability of different kind of paints. Gunnery tests on the Meppen test ground also showed that 28 cm APC projectiles fired from 4,000 meters easily penetrated the 300 mm belt armor, the deck armor and the torpedo bulkhead of the *Nassau* section. As a result, the Germans decided to increase the thickness of the belt armor to 350 mm on their third dreadnought class (*Kaiser* class).¹²⁸

The Germans carried out expensive underwater explosion tests from 1906 on test beds which represented full scale battleship and battlecruiser sections. These tests were carried out with the newest 50 cm torpedo warheads which were filled with a 125 kg explosive charge. These tests demonstrated that the armored torpedo bulkheads (30–40 mm thick) near to the side shell plating did not work well; the splinters from the breaking armored bulkhead caused by the explosion pierced the next, thin bulkhead. The Germans concluded that 4–4.5 m was the proper distance between the side shell plating and the armored bulkhead. They also found that the coal stored between the inner plating of the double hull and the torpedo bulkhead successfully absorbed a part of the energy of the explosion. The other important factor of the underwater protection was the minute subdivision of the German dreadnoughts. The Germans subdivided their dreadnoughts with as many watertight compartments as possible and eliminated doors in the watertight bulkheads.¹²⁹

Koudelka showed to Tirpitz one of the Popper's design (No. VI), which had ten 30.5 cm guns in five twin turrets, all on the centerline. This was similar to the British *Orion*. Tirpitz criticized the design's torpedo protection (torpedo bulkhead was only 2 m from the side shell plating) and pointed to the German test results again. In his opinion such an armament was too heavy for a 20,000 ton battleship. Tirpitz advised to sacrifice a gun turret and increasing the thickness of the belt armor to 300 mm and decreasing the casemate armor to 150 mm. Tirpitz proposed for this design a turret arrangement similar to that of the British battlecruiser *Invincible*. Before Koudelka left Tirpitz's office the Admiral called his attention again to the

importance of the torpedo protection and the watertight bulkheads.¹³⁰

Koudelka handed his top secret report in a sealed envelope on 3 May to Montecuccoli personally.¹³¹ However, for unknown reasons it appears that little was done with this information during the final stage of the design of the 20,000 ton battleships to improve the torpedo protection system. Austria-Hungary's first dreadnoughts were built using Popper's torpedo protection system of which Koudelka's report clearly showed that it was flawed in light of German test results. This led to the tragic loss of two of the four battleships.

Finalizing the 20,000 Ton Design

Two days after Koudelka handed his secret report to Montecuccoli, the STT sent to the Marinesektion a radically new design, designated as No VIII, which had been made at the personal request of Montecuccoli. The new design was armed with twelve 30.5 cm/45 guns in four triple turrets and with ten 15 cm guns in casemates. The thickness of the design's belt armor was 230 mm and she had two tripod masts.¹³² This was the first design which resembled the battleships as they were actually built.

In the course of the design process of the new battleship, more and more details of the Italian battleship design became known which influenced the Austro-Hungarian plans to a great extent. In December 1908, it had come to the light that the Italian dreadnought was to be armed with twelve 30.5 cm guns, arranged in four triple turrets. The original idea of triple turrets came from Russia: the Russian Navy drew up their specification in December 1907 for battleships which would carry twelve heavy guns in four triple turrets, all on the centerline. The Russians believed that broadside fire was much more important than end on fire, so they prescribed in their specification the "linear" arrangement of the turrets distributed over the length of the ship. The Italian naval constructor, Vittorio Cuniberti was among the fifty-one competitors for the contract, and imported the idea and the arrangement of the turrets. The first Italian dreadnought, the *Dante Alighieri*, was designed by Edoardo Masdea along the Russian principles, but the Italian ship had a raised forecastle deck.

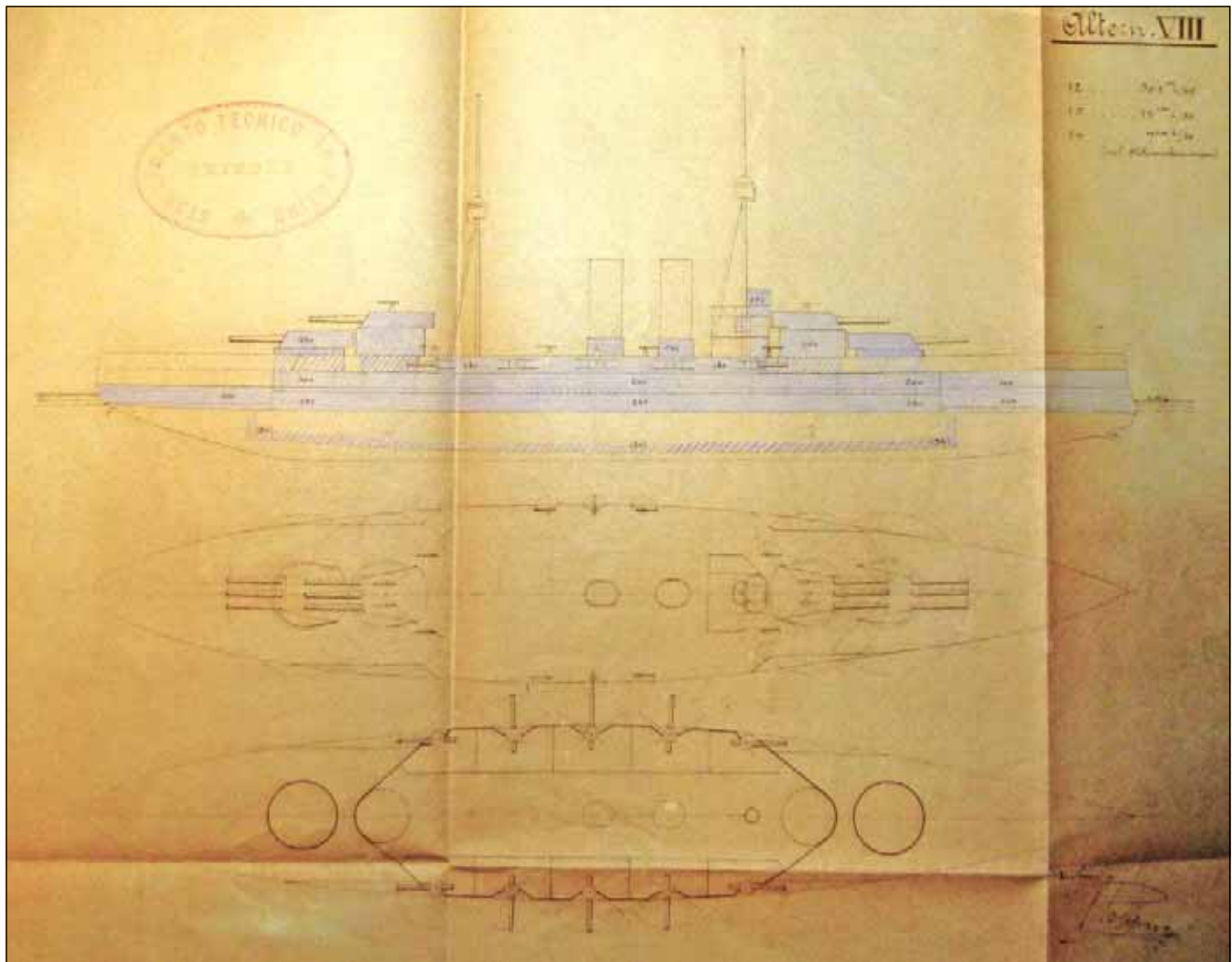

25 The STT/Popper design No VIII armed with twelve 30.5 cm guns in four triple turrets

The turret arrangement of the Austro-Hungarian No VIII differed from the Italian *Dante Alighieri*'s: the Austro-Hungarian ship had two turrets on the bow and two turrets on the stern, the second superimposed over the first and the third over the fourth turret. This arrangement provided heavier bow and stern fire and better allocation for the machinery spaces and the secondary battery, but on the other hand this arrangement put greater stress on the ends of the hull and the ship became top-heavy.

From the existing files of the design process of the first Austro-Hungarian dreadnoughts it is impossible to find out exactly when the Navy began to consider the use of triple turrets. The first mention of triple turrets is from 14 April 1909 in a note written by hand on a separate small, unsigned piece of paper: "triple turret 635 tons".¹³³ When Koudelka visited the Reichsmarineamt in Berlin in April, Admiral Tirpitz already knew that the Austro-Hungarian Navy was considering the idea of using tri-

ple turrets.¹³⁴ The Germans also were interested in triple turrets and the Austro-Hungarian Navy gave permission to the German Navy to examine the turrets of the *Viribus Unitis* during a gunnery practice in July 1913.¹³⁵ It is clear that many officers, naval architects and engineers in the Navy were not enthusiastic about the triple turrets;¹³⁶ it seems that it was rather a personal choice of Montecuccoli who wanted to copy the armament of the Italian battleship. To examine the possible problems of a triple turret (ammunition supply of the central gun, ventilation) the Škoda built a large-size model of a triple turret¹³⁷ which is today on display at the Heersgeschichtliche Museum in Vienna.

On 9 June 1909, the Navy drew up new specifications for the dreadnoughts: displacement of 20,500 tons, belt armor of 280 mm, casemate armor of 160 mm, twelve 30.5 cm/45 main battery, twelve 15 cm/50 secondary battery, four underwater torpedo tubes, Parsons steam turbines and coal



26 The 30.5 cm/45 triple turret model made by Škoda.
 Note the projectile with AP cap but without ballistic cap on the loading car.
 Note also the connecting trays between the main and the auxiliary ammunition hoists

fired Yarrow boilers with oil-spraying, two masts, one for the fire control position and one for the searchlights. The design also showed an aft conning tower and two armored fire control positions for the secondary battery. These specifications were sent to the MTK and the STT.¹³⁸

The specification on the torpedo protection system was the following: “About the *Minenpanzer* (torpedo bulkhead) it is to be mentioned that it may be advantageous to build a longitudinal bulkhead between it and the hull and this *Kofferdamm*¹³⁹ to be used for the storage of reserve coal.”¹⁴⁰ Even a sketch drawn by pencil was attached to this part. This arrangement was very similar to the one described in Koudelka’s secret report one month earlier. “The Reichsmarineamt held on the basis of the test results that on every new ship the simple bulkhead had to be built in the outer position and the armored bulkhead in the inner position and the space between them had to use as storage of coal which could be emptied only in case of emergency.”¹⁴¹ This demonstrates that the Navy tried to use the precious information brought by Koudelka, but

perhaps not hard enough. The Navy did not specify precisely the desirable depth of four meters of the protective system which was a mistake. However, the increase of the belt armor to 280 mm may have been a consequence of Koudelka’s report.

On 21 June, Popper presented six 20,500 ton designs. Designs A and B were new designs while the C, D, E and F were modifications of earlier designs. Designs A and C or B and D had the same main armament but their turret arrangements were different. Design A was similar to the German battlecruiser *Moltke* with two wing turrets *en echelon* while design C was similar to the British *Orion* with all turrets on the centerline. Design B had two triple turrets at the ends and two wing twin turrets while design D had two triple and two twin turrets at both ends, with the twins being in superimposed position. The depth of the torpedo protection system was 1.2 + 0.74 m, the thickness of the torpedo bulkhead was 50 mm.¹⁴² It is unclear if this 1.94 m is the distance of the torpedo bulkhead from the side shell plating or from the inner plating of the double hull, but most probably this is the full

The STT Designs Made by Popper June 1909¹⁴³

	<i>Dimensions (m)</i>	<i>Belt (mm)</i>	<i>Main battery</i>	<i>Secondary battery</i>
A	155×26	240	10×30.5 cm, five twins	14×15 cm
B	155×26	280	10×30.5 cm, two triples, two twins	14×15 cm
C	151×26	280	10×30.5 cm, five twins	14×15 cm
D	151×26	280	10×30.5 cm, two triples, two twins	14×15 cm
E	151×26	270	11×30.5 cm, three triples, one twin	14×15 cm
F	151×26	240	12×30.5 cm, four triples	14×15 cm

depth of the system considering the designs with wing turrets.

On the order of the Marinesektion the MTK formed a board presided by Kontreadmiral Luzian von Ziegler on 3 July 1909 to examine the main battery of the designs of Popper. One of the board members was Kontreadmiral Karl Lanjus von Wellenburg (who was killed in August 1913 when a 30.5 cm gun exploded during proof testing). They excluded at the first the designs with wing turrets (A, B), as they favored the all turrets on centerline arrangement of designs C and D on the grounds that it made possible for arranging for superior torpedo protection. On strictly weight saving grounds design D was their favorite.¹⁴⁴ Despite this, the board was in favor of using twin turrets as they had a few objections against the triple turret designs. With its larger barbette (9 m instead of 7.8 m), they considered the triple mounting to be a larger target and thus easier to hit. It was suggested that the powder smoke from firing the three guns would hinder the fire control of the turret. They considered the most serious objection against the triple turret was that a hit or a mechanical failure could put out of action a greater percentage of the main battery than would a similar hit on a twin turret. They also feared that the triple turret, being a novel mechanism, would suffer teething problems. The board in its report declared that the armor penetration capability of the shorter, 45 caliber length 30.5 cm gun was sufficient.¹⁴⁵

The board's conclusion was that design C with five twin turrets all in centerline was best if the displacement limit was strict. In the case that the Navy would accept a 550 tons increase of the dis-

placement, they recommended the slightly modified design F with four triple turrets, but they still maintained their concerns over the triple turret.¹⁴⁶

On 6 August 1909, the Navy drew up the final specifications and sent to the MTK and the STT with the following particulars: four triple turrets, minimum thickness of belt armor 280 mm (300 mm if possible), displacement of 21,000 tons maximum, Parsons steam turbines without cruising turbines, coal firing boilers with oil spraying.¹⁴⁷ The final design of the new battleships was set. After this date only one attempt was made to make a minor change in the design, but it was soon aborted. The Navy wanted to double the end on fire capacity of the 15 cm casemate guns (four guns instead of two) but when they learned that it would be possible only by decreasing the thickness of the belt armor to 230 mm, they rejected this plan.¹⁴⁸ In the spring of 1910, Schiffbauingenieure Franz Pitzinger and Theodor Nowotny presented their own designs based upon the 9 June specifications¹⁴⁹ but at that time the detailed designs were already under way.

Works on the detailed designs started in the autumn of 1909. The time was short because the construction of the first unit needed to be started in the spring of 1910. In the case of the *Radetzky* class the Navy had had a whole year to complete the detailed designs while in the case of the dreadnoughts only six months was available. Another great problem was the overwhelming design work needed for the new battleships. Everyone knew that for such a heavy armament a 22,000 ton ship would have been desirable. However, Montecuccoli had put great pressure on the Navy as he



27 Aft 30.5 cm/45 triple turrets on Viribus Unitis

forced the twelve guns armament while still adhering to the 20,000 tons displacement limit. The strict displacement limit was important for Montecuccoli because he feared presenting the costs of larger and thus more expensive battleships to the politicians. The results of Montecuccoli's insistence on the heavy armament and the strict displacement limit of this design were the weak hull structure and inadequate watertight bulkheads of the *Tegetthoff* class battleships.

In one phase of the work on the detailed designs in October-November 1909 the thickness of the

belt armor was increased to 300 mm, but against Tirpitz's advice, this was not compensated by reducing the thickness of the casemate armor (from 180 mm to 150 mm).¹⁵⁰ Kontreadmiral Ziegler, the head of the MTK on 30 November 1909 wrote a report on the hull structure of the projected battleships. In his opinion the hull structure was too weak thanks to the extensive weight savings and he proposed two extra longitudinal frames to reinforce the hull structure. The extra weight of these frames were to be compensated by reducing, by his own words, the "oversized" belt armor down to 290

mm.¹⁵¹ The final result of this was that the reinforcement of the hull structure resulted in the return to the original 280 mm belt armor.¹⁵²

The torpedo protection system of the 20,000 ton battleships differed from the system used on the *Radetzky* class but it was not much more efficient. On the battleships of the *Radetzky* class the 54 mm thick inner side of the double hull was the torpedo bulkhead and the depth of the system was 1.5-2 meters. On the dreadnoughts there was a *Kofferdamm*, a vault space between the inner side of the double hull and the 50 mm thick torpedo bulkhead and the depth of the system was 2.4-2.8 meters. Between the torpedo bulkhead and the 15 cm and 7 cm magazines bulkheads there was another *Kofferdamm* of 0.9-1.2 m closed in by a light 9 mm bulkhead. The specification of 9 June and especially the attached sketch drawing described a different system arrangement: there was a vault space between the inner hull and a light bulkhead and there was another space for reserve coal between the light bulkhead and the torpedo bulkhead. This system was at least 1-1.2 meters deeper than that of Popper. Looking at the plans of the *Tegetthoff* class, it is obvious that there was the possibility to form a deeper protective system by changing the torpedo bulkhead and the light bulkhead of the magazines without any further serious modifications. This system would have been 3.6-3.8 meters deep at the boiler and machinery rooms and 4-4.5 meters deep at the 30.5 cm magazines. It is still a secret why the Navy accepted Popper's arrangement while many of their officers and naval architects were fully aware of the flaws of his system.

On 11 November 1909, Montecuccoli informed Tirpitz in a letter that the Austro-Hungarian Navy was to build 20,000 ton battleships with four triple turrets. In his letter of 26 November Tirpitz expressed his well-wishes to Montecuccoli for "choosing such an original type of battleship".¹⁵³ Later Tirpitz became the most vehement critic of the Austro-Hungarian dreadnoughts.

The Final Design

The displacement of the *Tegetthoff* class was 5,500 tons or 38 percent greater than the displacement of the *Radetzky* class, which was the greatest leap in the history of the Austro-Hungarian Navy. The

greatest part of the increase was the result of the increases to the armament and the armor protection, whereas the speed of the two classes was nearly identical. The weight of the vertical armor was 1,300 tons or 35 percent greater, the thickness of the belt armor was increased by 22 percent (from 230 to 280 mm) while the thickness of the casemate armor was increased by 50 percent (from 120 to 180 mm). The weight of the main battery including gun turrets rose from 1,833 tons to 2,798 tons (53 percent). Even the price of the new battleships was much greater: 60.6 million Kronen per unit against the 39.3 million Kronen per unit price of the *Radetzky* class.

The main battery of the *Tegetthoff* class consisted of the same 30.5 cm/45 Škoda guns which were used on the *Radetzky* class, but twelve of them were mounted on the new battleships instead of four. At the time of the design process (1908-1909), the Navy was content with the 30.5 cm caliber and considered it sufficient even with the shorter, 45 caliber length version of this gun after reviewing the problems that Škoda had had with the development of the 50 caliber length version. The 30.5 cm guns of the *Tegetthoff* class slightly differed from the earlier guns: these guns were designated as K10 and their chambers were 5 cm longer so that they could handle a heavier propellant charge in a longer case. The ammunition hoists of the triple turrets were also larger so that they could handle the longer 5 crh projectiles. These more streamlined projectiles gave the gun somewhat greater range. The Škoda manufactured fifty-two K10 guns in total, four of them being spares.

The twelve 30.5 cm guns were mounted on four triple turrets, two turrets were in the bow and two turrets were in the stern all on the centerline and the two inner turrets were in superimposed position. This turret arrangement gave the ships a heavy six guns end on fire capability and a twelve gun broadside fire capacity. The triple turrets were much heavier than originally designed, they weighed 682-692 tons (superimposed turrets were heavier) without the armored cupolas of the turret rangefinders instead of the 623 tons weight guaranteed by the Škoda. The turrets were all electric operated (train, elevation and ammunition hoists). The four turrets were fed by four 300 KW turbine-driven dynamos. Breeches, loading cars and chain rammers were hand operated. From

1913/1914, every turret was fitted with a coupling device that allowed the guns to elevate together. When the three guns of a turret were coupled together their maximum elevation was reduced and range was thus limited to 18,500 m.¹⁵⁴ Each turret was fitted with a 9-foot Barr & Stroud rangefinder in an armored cupola on the turret roof.

The secondary battery consisted of twelve 15 cm/50 guns in casemates on the Batteriedeck. There were two small armored fire control towers for the 15 cm batteries on both sides of the ship on the Oberdeck (upper deck). The light anti-torpedo boat battery consisted of eighteen 7 cm/50 guns on the Oberdeck. During the war three or four 7 cm/50 AA guns were mounted on the roofs of the superimposed turrets. The ships were fitted with four submerged 53.3 cm torpedo tubes, one in the bow, one in the stern and two on the broadsides.

The weight of the vertical armor was 5,000 tons. The main belt was 280 mm thick tapered to 180 mm under the waterline. Forward and aft of the barbettes of the first and the fourth 30.5 cm turrets the belt reduced in thickness to 150 mm. The upper belt and the casemate armor was 180 mm thick. The sloped parts of the armored deck were 48 mm thick while the midship part was 36 mm thick. Because the casemate armor ended at the superimposed turrets, the Batteriedeck was reinforced over the magazines of turrets No I, No III and No IV. The lack of the side armor (over the upper belt) was compensated by the thickening of the Batteriedeck from 15 to 30 mm in these areas. The Batteriedeck was one level above the armored deck (Mitteldeck). In these areas the vertical armor protection was 30+36 mm while over the magazines of the turret No II it was only 15+36 mm, but here the vertical armor reached the Oberdeck which was 30 mm thick

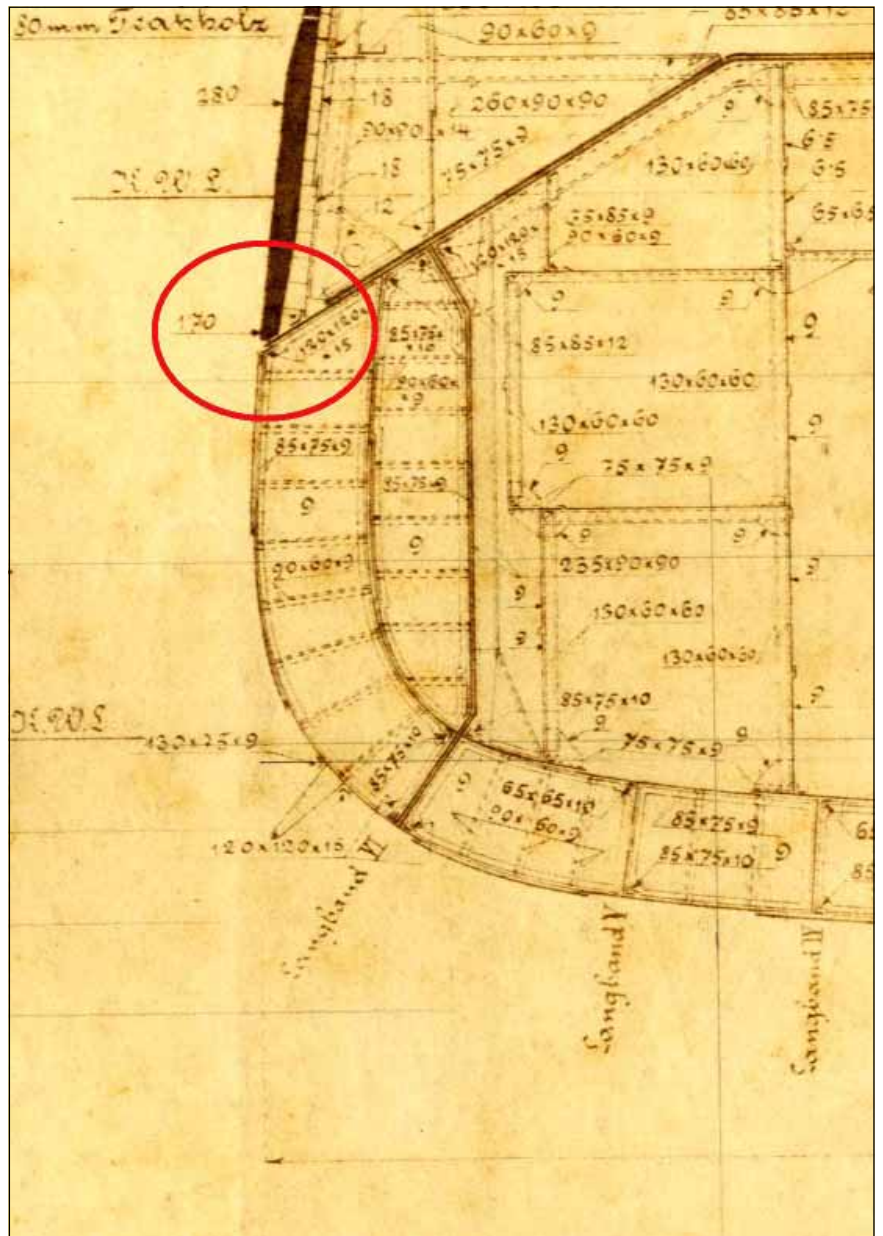

28 The torpedo protection system of the Tegetthoff class designed by Popper.

The maximum depth of the system is 2.6 m.
The circle indicates the thin (18 mm) outer edge
of the sloped part of the armored deck

over the 15 cm casemates. The barbettes of the 30.5 cm turrets were 280 mm thick above the Batteriedeck. The lowest part of the barbettes, which were directly above the armored deck, was 80 mm thick. The face and the sides of the turrets were 280 mm and the sloped parts 200-130 mm thick, while turret roofs were 60 mm thick. The conning tower had 280 mm thick sides and a 60 mm thick roof. The aft conning tower had 150 mm sides and 40 mm roof.

As it was mentioned earlier, the torpedo protection system of the *Tegetthoff* class differed from

the system of the *Radetzky* class but was not much more effective. The 50 mm thick torpedo bulkhead ran from the first to the fourth gun turret and the distance between it and the side shell plating was 2.4-2.8 m, which was far from adequate. The torpedo protection systems of the *Tegetthoff* and the *Radetzky* classes had another serious and common fault. On both classes the last 1-1.2 m wide section of the sloped part of the armored deck (18+30 mm) where it was attached to the side shell plating was only 18 mm thick. As the Austro-Hungarian underwater explosion test of June 1914 demonstrated, a single 18 mm deck could not withstand the explosion of a 45 cm torpedo warhead of 110 kg. A Hungarian diving expedition which explored the wreck of the *Szent István* in 2008 reported that there was a wide gap between the side shell plating and the above mentioned part of the armored deck above the hole made by the torpedo.¹⁵⁵ This fault exposed a serious danger that following an underwater explosion not only the compartments under the armored deck would be flooded but also the compartments above it could be flooded.

Even the Navy was fully aware of the weak construction of the watertight bulkheads of the Austro-Hungarian battleships. This was less problematic on the battleships built earlier because their bulkheads had smaller surfaces. Thanks to the weak bulkheads, on these ships it had to store great quantity of timber to support the bulkheads in case of emergency. The bulkheads were further weakened with watertight doors cut in them even on the *Tegetthoff* class which was against the advice of Tirpitz. The construction of the bulkheads of the different units of the *Tegetthoff*-class was not identical. The vertical stiffeners (L profiles) of the bulkheads on the *Viribus Unitis* and *Tegetthoff* were spaced by 610 mm while on the *Prinz Eugen* they were spaced by 570 mm. On the latter ship two additional horizontal stiffeners reinforced the watertight bulkheads. At a later date two horizontal stiffeners were riveted to the bulkheads of the first two Trieste-built dreadnoughts.¹⁵⁶ In 1914 the Navy made so-called caisson tests with similarly constructed ½ scale bulkheads. The test results were not very promising for the *Tegetthoffs*: converting the data to 1/1 scale bulkheads the engineers of the MTK came to the conclusion that the pressure of a 5-6 m high water column could cause a 30 cubic meters per hour leakage through the bulkhead.¹⁵⁷

The shape of the hull and the silhouette of the ship were similar to that of the *Radetzky*s. Both battleship classes were flushdeckers and they had two funnels and two pole masts. The *Tegetthoffs* were extremely beamy ships among the battleships of that time; their length/beam ratio was 5.43 (152.3×28 m). Thanks to the relatively short hull, the lack of the raised forecastle deck and the heavy and voluminous armament, the crew compartments were extremely overcrowded. The superimposed triple turrets rendered the ships top heavy and unstable. The ships were also bow heavy thanks to their heavy and anachronistic ram. Due to the low freeboard and the shape of the bow they were wet ships. At a speed of 16-17 knots even on calm sea the foredeck was constantly wet. Thanks to all of the structural weight savings, the structure of the hull was weak. During dockings the heavy weight of the triple turrets caused distortions in the structure of the double bottom, especially under the aft turrets.

The ships of the *Tegetthoff* class were the first Austro-Hungarian battleships built with steam turbines. The first turbine-powered ship of the Austro-Hungarian Navy was the 3,500 ton scout cruiser *Admiral Spaun*. The weight of the machinery complex of a *Tegetthoff* class battleship was approximately 1,500 tons (*Szent István* 1,640 tons). The machinery was consisted of two sets of direct drive Parsons-turbines (*Szent István* AEG-Curtiss) without cruising turbines and twelve coal firing Yarrow (*Szent István* Babcock-Wilcox) watertube boilers with oil spraying. The boilers of the *Szent István* were fitted also with superheaters. On the three Trieste built ships each stage (HP, LP) of the turbine sets drove its own three bladed manganese bronze screw of 2,700 mm diameter, so these ships had four screws. On the Danubius built ship the two stages were coupled in line together as on the German dreadnoughts so each turbine set drove one three bladed manganese bronze screw of 4,000 mm diameter. The design power output of the machinery was 25,000 SHP and the design speed of the ships was 20 knots. The twelve boilers were arranged in two boiler rooms, six boilers in two rows in each. Each boiler room had its own funnel. The ships could carry 1871 tons of coal and 162 tons of fuel oil which enabled a maximum range of 5000 nautical miles at a cruising speed of 10 knots. The *Szent István* could carry 267 tons of fuel oil.

Political and Financial Background

The first steps were taken in 1906 to pave the way for the new battleships class. On 4 July 1906, Montecuccoli declared before the Austrian Reichsrat if the British *Dreadnought* were not a unique ship Austria-Hungary should build 20,000 ton battleships to follow the international trend.¹⁵⁸ In November 1906, during the delegation's meeting session in Budapest Montecuccoli who was staying in the Hungarian capital sent his secretary, Korvettenkapitän Alfred von Koudelka to find out the opinion of the Hungarian politicians about the new battleships. Koudelka negotiated with Hungarian delegation members who backed the plan. On the next day Koudelka met with members of the Hungarian government. Prime Minister Sándor Wekerle told him that Hungary would assert to the dreadnoughts if one third of the cost would be spent in Hungary. Commerce minister Ferenc Kossuth added that one of the battleships should be built in the Danubius shipyard in Fiume. When Koudelka gave an account of his negotiation with the Hungarian government to Montecuccoli in the hotel room the Marinekommandant allegedly cried

out: "That battleship will be never completed!" Allegedly (by his own account) Koudelka saved the situation by proposing that it should build four battleships instead of three and even if the Danubius would have serious problems the Navy would possess a class of three battleships.¹⁵⁹

After the first, preliminary steps the political and propagandistic offensive started in 1908. In February 1908, Montecuccoli presented a memorandum of thirty pages to the Emperor and both governments. The memorandum contained an ambitious fleet program of sixteen battleships, twelve cruisers, twenty-four destroyers, seventy-two torpedo boats and twelve submarines. He urged to build four 18,000-19,000 ton battleships stating that Italy had hostile intentions. He also stated that Italy had started to build four 19,000 ton battleships primarily against the Monarchy. Montecuccoli lamented that among the European Powers the Monarchy was spending the least on the Navy. He stated that in 1907 Italy had spent 2.41 Kronen per capita on its Navy while the Monarchy had spent only 1 Krone per capita.¹⁶⁰ In fact, there were no Italian battleships under construction in 1908 and the Monarchy spent 1.7 Kronen per capita on



29 *The first Italian dreadnought, the Dante Alighieri armed with twelve 30.5 cm/46 guns in four triple turrets*

the Navy. Common War minister Franz Schön-aich told Montecucoli that the difficult financial situation of the Army would not render possible to build new battleships in the near future.¹⁶¹ As a matter of fact, it was the news of the Austro-Hungarian dreadnought project which accelerated the Italian dreadnought program in the first half of 1909. In June 1909, the 19,500 ton *Dante Alighieri* was laid down in Castellamare.

The propaganda was started in the monthly magazine of the Österreichische Flottenverein "Die Flagge" in November 1908. The leading article urged the replacement of the old *Monarch* class with 19,000 ton battleships to counterbalance the Italian threat.¹⁶² In February 1909, the magazine made propaganda for a whole program of four 20,000 ton battleships, four cruisers and several torpedo boats. The estimated costs of the program were 250 million Kronen.¹⁶³

On 31 October 1908, Montecucoli declared before the Austrian delegation that the Navy was working on designs of 18-19,000 ton battleships and so called "rapid cruisers".¹⁶⁴ Juraj Biankini, a catholic priest and a representative from Zara said that the Navy was threatened from two sides: by Italy which was seeking revenge for Lissa and by Hungary which was trying to cut the Navy's budget. He criticized also Montecucoli's pro-Hungarian policy.¹⁶⁵

The news of the Austro-Hungarian dreadnought project provoked hysterical reactions in Britain and France at the end of 1908. During 1909, the British press printed many articles regarding the Austro-Hungarian dreadnoughts. The principal cause of the panic in Britain and France was the fact that the Dual Monarchy was an ally of Germany and a joint force of Italian and Austro-Hungarian dreadnoughts could seriously threaten the British and French positions in the Mediterranean. In Britain the panic reached its culmination in the summer of 1909 when it was thought that Italy and Austria-Hungary soon would possess together sixteen or more dreadnoughts. Things calmed down somewhat in the first months of 1910 when it became obvious that the Austro-Hungarian dreadnought construction would be subject to delays due to financial problems.¹⁶⁶ The British Admiralty believed that Dual Monarchy was building dreadnoughts per German instructions. In fact, the British overstated Vienna's loyalty to Ber-

lin and understated the rivalry between the Dual Monarchy and Italy. In December 1910, when the delegation's voting for the dreadnoughts was near, the French Naval Attaché in Vienna, Joliot de Faramond, advised his government not to allow Austria-Hungary to list bonds on the Paris money market. "It would be a generous folly on our part to aid the development of the Austro-Hungarian Navy with our money," he wrote.¹⁶⁷

In July 1909, the Navy initiated negotiations with Manfréd Weisz,¹⁶⁸ member of the directorial board of the Danubius Shipyard, and with the Hungarian Ministry of Commerce. During these negotiations the Navy urged the shipyard and the government to increase the capacity of the Danubius Shipyard to allow the construction of the newer and larger battleships.¹⁶⁹ On 12 July 1909, undersecretary of state József Szerényi¹⁷⁰ negotiated in Vienna with Vizeadmiral Leodegar Kneissler von Maixdorf, the deputy Chef der Marinesektion. Szerényi promised that the Hungarian State would build the railway to the Danubius Shipyard. He asked in return the Navy to guarantee orders for the next six years including two battleships.¹⁷¹ On 25 July, Fregattenkapitän Koudelka and Oberingenieur Wagner negotiated in Budapest with the directors of the Danubius and the representatives of the Ministry of Commerce. Szerényi asked in exchange for voting to approve the costs of the new battleships and the development of the Danubius at the expenses of the state, the Danubius Shipyard would receive the order of one battleship and 50 percent of all future shipbuilding orders, the latter as a compensation for the Austrian gun and armor deliveries.¹⁷²

At the 14 September 1909 meeting of the common Council of Ministers, Montecucoli presented the project of the new battleships to the common ministers and the representatives of the Austrian and the Hungarian government. Every member of the council agreed with the need for the new battleships, but there was a disagreement over the method of financing. The Austrian Finance minister and the Hungarian Prime Minister took the view that the expenses of the battleships should be covered from a new extraordinary credit. At the 18 September meeting Montecucoli asked an extraordinary credit of 309 million Kronen and presented a program of four dreadnoughts, three cruisers and several destroyers and torpedo boats.

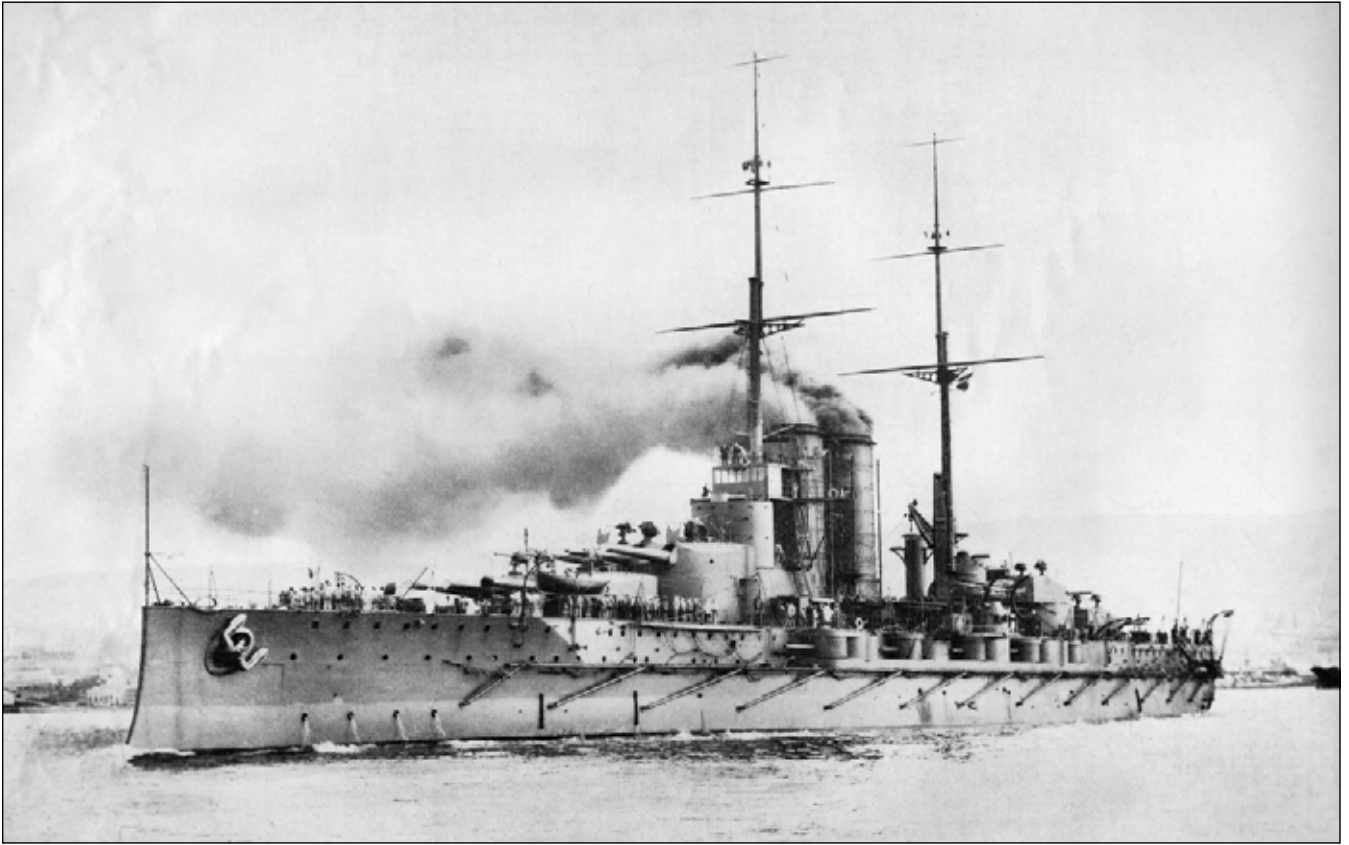

30 Viribus Unitis, the flagship of the Austro-Hungarian Navy

Foreign minister Alois Lexa von Aerenthal supported the program with reference to Italy as an unreliable ally. Even the Hungarian Prime, Minister Sándor Wekerle supported the program.¹⁷³ Everything seemed favorable for the Navy but there was a great problem: due to the Hungarian political crisis, the delegations could not meet and vote for the budget for 1910. It was clear even in August 1909 that thanks to the uncertain Hungarian political situation that the meeting of the delegations should be postponed indefinitely.¹⁷⁴

On 22 September, Montecuccoli was received at a private audience by Emperor Franz Joseph. They discussed the naval budget and the extraordinary credit. Due to the Hungarian political crisis even the Emperor could promise nothing.¹⁷⁵ Two days later, on 24 September the Heir of the Throne negotiated via his Military Chancellery with the Navy on the battleships. Franz Ferdinand considered important the construction of the four dreadnoughts with regard to the Italian naval buildup. Both Franz Ferdinand and Montecuccoli worried about the Hungarian political crisis and feared that the building of the dreadnoughts would be delayed. The planned amount of the extraordinary

credit at that time was 309.5 million Kronen while the planned price of a battleship was 57 million Kronen.¹⁷⁶

Montecuccoli did not give up the idea of starting the construction of the battleships at the earliest possible date. His plan was backed by the Heir of the Throne. Montecuccoli negotiated with the STT Shipyard as early as on 16 July 1909 on the possibility of building two battleships formally at their own risk with the guarantee of taking over them when the delegations approved the budget.¹⁷⁷ Montecuccoli negotiated similar deals with Skoda¹⁷⁸ and Witkowitz. The plan was backed financially by the Austrian Rothschilds through their bank Boden-Creditanstalt, whom had governing interests in all the three firms. But as 120 million Kronen was not a small sum, the Rothschilds asked for some guarantees. Allegedly, the Heir of the Throne, who was not known to be a great pro-Semite, personally visited Baron Albert Rothschild regard to the guarantees. The negotiations with the three firms ended with success in October 1909.¹⁷⁹ On 29 November 1909, the Navy signed the contract with STT on the building of the *Schlachtschiff IV* and *V*.¹⁸⁰

The news of the contract soon reached Budapest but in a somewhat distorted form. On 1 December 1909, the Hungarian Ministry of Commerce protested at the Marinesektion because the Ministry had been informed that the Navy had ordered four battleships without the consent of the delegations, two in the STT, one in the Cosulich Shipyard and one in the Pola Arsenal, and that Škoda had already manufactured eleven 30.5 cm guns.¹⁸¹ In his letter of 23 December 1909 Montecuccoli informed the Ministry that the STT had started the building of two battleships at its own initiative and risk and the Navy had only promised to take over them after the delegations had approved the credit. He added that the Navy was carrying on similar negotiations with the Danubius Shipyard. He told that the Cosulich Shipyard was unable to build such a great ship, the Arzenal could accept only official orders and the eleven 30.5 cm guns in the Škoda were manufactured for the *Radetzky* class.¹⁸²

In Austria the major political forces, Christian Socials, German nationalists, South Slavs and even, half-heartedly, the Czechs, supported the development of the Navy. Only the Social Democrat Party was a consistent opponent of the increased naval spending. Because the Navy took it for granted that the Austrian delegation would support the dreadnought program, its most important task was to win over the Hungarian government and delegation to the battleship construction. The Navy had certain worries about the quality of the Hungarian built ships, but for political reasons it had to accept that it should order one of the battleships from the Danubius Shipyard.

On 9 November 1909, the Danubius Shipyard asked the Marinesektion for the first time for new orders.¹⁸³ On 6 December Aerenthal, in accordance with the Military Chancellery of the Emperor, informed Montecuccoli that even if the Hungarian government would raise objections against the battleship order (which had been occurred on 1 December) it could still start negotiations with the Danubius Shipyard for them.¹⁸⁴ On 12 December 1909, Montecuccoli informed the Danubius if the shipyard would start to build a battleship at its own risk then the Navy would promise to take over the ship after the credit was approved by the delegations.¹⁸⁵ On 18 February 1910, the Danubius turned to the Marinesektion again asking for orders. Because there was no appropriation in the

budget for new ships the Navy could only propose the building at the shipyard's own risk again.¹⁸⁶ The Danubius was in trouble because a part of the shipyard's territory was the property of the Hungarian State and it was clear that without the assistance of the state the needed development of the shipyard would be impossible, and the Hungarian government strongly opposed the shipyard participating in the building at its own risk.

The Hungarian Ministry of Commerce and the Danubius Shipyard on 24 May 1910 agreed on the acquisition of the much needed new territory. The Hungarian Treasury bought a 75,000 square meters plot of land from the Whitehead and leased it to the Danubius for a minimal rent.¹⁸⁷ On 23 June 1910, the Danubius informed the Marinesektion of this agreement. The Danubius asked the intervention of the Ministry of Commerce for the order of the battleship but the Ministry refused it, answering that the Hungarian government had not yet agreed officially to the construction of the new battleships. On the other hand, the Ministry told that it would be very important the question of the share of the Hungarian industry from the orders when time of the voting for the naval budget would come.¹⁸⁸

The common Council of Ministers on 17 May 1910 discussed again the new battleships. Montecuccoli said that even Spain and Turkey would start to build dreadnoughts while in Italy four dreadnoughts were already under construction. Then he presented his program of four battleships, three cruisers, six destroyers, twelve torpedo boats and six submarines. He reminded the Council of the fact that two dreadnoughts were under construction in Trieste and negotiations were underway with the Danubius and with the Cantiere Navale Triestino (CNT) of Monfalcone. Montecuccoli estimated the costs of the whole program about 330 million Kronen. The Austrian Finance Minister said that the expenses of the program could only be covered by an extraordinary credit. Common Foreign minister, Aerenthal put forth two options: The Council either would wait or would deal with the matter of the battleships in an unconstitutional way.¹⁸⁹

The common Council of Ministers discussed the extraordinary credit for the navy on 6 October 1910. Both Ministers of Finance maximized the credit in 312.4 million Kronen. The Austrian Prime Minister Baron Richard von Bienerth proposed the cancellation of the torpedo boats but

Montecuccoli protested against it. The Marinekommandant reminded again of the two dreadnoughts under construction in the STT. He proposed that the third unit could be built in the Pola Arsenal while the fourth in the STT after the launch of the first unit. Hungarian Finance minister László Lukács remarked that one battleship could be built in Hungary. Montecuccoli told him that the Danubius would only be able to build a battleship after 1912 and there were other ways to give orders to the Hungarian industry. At last, Bienert asked Montecuccoli to rework his program.¹⁹⁰ At the 20 November meeting Aerenthal laid before the Council of Common Ministers the reworked proposal for an extraordinary credit of 312.4 million Kronen.¹⁹¹

After a long interval the Delegations met in November 1910. The naval budget was laid before the delegations in February and March 1911. On 31 January 1911, in the Hungarian Ministry of Commerce the representatives of the Hungarian government and the Navy made an agreement on the distribution of the 312.4 million Kronen extraordinary credit. The representatives of the Navy presented their proposal, in which 110.4 million Kronen fell on the Hungarian industry to the

Commerce minister, Károly Hieronymi, and the head of the naval sub-committee of the Hungarian delegation, Dr. Gyula Rosenberg. Hieronymi asked to increase this sum to 113.7 million Kronen which was immediately accepted by the representatives of the Navy. A few days later, a detailed written agreement was made on the distribution of the industrial orders between the Austrian and Hungarian industry. On the basis of this agreement, the orders of one battleship, two cruisers, six torpedo boats, six submarines and about the half of the ammunition went to Hungarian industry.¹⁹² Naturally, there were negative reactions to this agreement in Austria, but that did not alter the case in the least. There were later some changes in the orders. The Navy ordered in 1913 the submarines (five instead of six) in Germany and ordered as compensation sixteen torpedo boats in the Danubius.

On 24 February 1911, Dr. Gyula Rosenberg laid before the Hungarian delegation the budget proposal of the Navy which included the extraordinary credit with the following words: "I defend a less popular case".¹⁹³ He tried to refute the rumors that the building of the new battleships would be a favor for Germany or would be directed against Italy.¹⁹⁴ After lengthy speeches and debates on 28

The share of the Austrian industry from the orders of the dreadnoughts (in million Kronen)

	IV	V	VI	VII
Hull&machinery	20.299	20.290	19.220	-
Armor	12.400	12.400	12.400	12.400
Armament	12.850	12.850	12.550	12.550
Propellant	-	-	-	-
Cartridge	1.010	1.010	1.010	1.010
Projectile	2.000	2.000	2.000	2.000
Fuze	0.300	0.300	0.300	0.300
Bursting charge	n. a.	n. a.	n. a.	n. a.
Electrical equipment	1.110	1.110	0.520	-
Magazines	0.750	0.750	0.750	-
Torpedo	-	-	-	-
Totals	50.719	50.710	48.750	28.260

The share of the Hungarian industry from the orders of the dreadnoughts (in million Kronen)

	IV	V	VI	VII
Hull&machinery	0.710	0.710	1.780	21.000
Armor	-	-	-	-
Armament	-	-	0.300	0.300
Propellant	3.710	3.710	3.710	3.710
Cartridge	1.010	1.010	1.010	1.010
Projectile	2.000	2.000	2.000	2.000
Fuze	0.300	0.300	0.300	0.300
Bursting charge	-	-	-	-
Electrical equip.	0.790	0.790	1.380	1.900
Magazines	0.750	0.750	0.750	1.500
Torpedo	0.620	0.620	0.620	0.620
Totals	9.890	9.890	11.850	32.340

February the Hungarian Delegation voted for the budget. Furthermore, the delegation voted for a resolution in which they gave the Marinekommandant vote of confidence, which was an unprecedented act in the history of the Hungarian delegation.¹⁹⁵

The proposal of the naval budget was laid before the Austrian Delegation on 1 March. During the debate some members of the delegation questioned the need of the battleships and proposed to invest this money instead in railway lines. Other members questioned the fighting value of the battleships while some other members questioned the ability of the Danubius to build a battleship. On the next day the Austrian delegation voted in favor of the budget.¹⁹⁶

The Construction of the *Tegetthoff* Class

During the negotiations on the building at the industries' own risk, coming to terms with the Škoda and the Witkowitz works was more important than with the STT because the determinant factors of the construction time of a battleship were the gun turrets and armor rather than the hull and machin-

ery. The task was challenging because the manufacturing of these items should take place over the same period (four years) as in the case of the *Radezky* class even though the new battleships had 20,000 tons of armor instead of 11,000 tons and their gun turrets weighed 11,000 tons instead of 5,400 tons. In August 1909, the Marinesektion informed Škoda that for the new battleships it should manufacture sixteen triple turrets and forty-eight 30.5 cm guns and for the first unit it should deliver the complete armament in 1912. Montecuccoli requested Albert Rothschild, the owner of Witkowitz Ironworks, to increase his armor manufacturing capacity to 7,000 tons per year. Rothschild was ready to accomplish this expansion, but he made mention of some risks.¹⁹⁷ During the negotiations the STT took the necessary steps for building the 20,000 ton battleships: the machinery shop was enlarged and the cranes of the two large slipways were heightened.¹⁹⁸

On 29 November 1909, the Navy signed the contract with the STT on the building of the first two units (*Schlachtschiff IV* and *V*). The delivery times were thirty and thirty-six months.¹⁹⁹ The price of the hull and the machinery of one unit were 14 and 7 million Kronen, the price of the complete

battleship with ammunition was 60.6 million Kronen. The STT deposited 4.2 million Kronen (10 percent) at the Creditanstalt in accordance with the contract.²⁰⁰ In January 1910, the Navy signed the contract with the Škoda on the armament.²⁰¹ On 9 November 1909, the Navy signed the contract with the Witkowitz Ironworks on the armor of the first two dreadnoughts.²⁰²

The preparatory works of starting the lofting process in the mold loft on the two battleships were started in the spring of 1910. The cover-names of the two units were *Objekt 427* and *Objekt 428*. Cover-names were needed because officially the Navy did not order these ships. It posed a problem that even in April 1910 some detailed plans were missing, so the subcontractors could not start to manufacture these parts in time.²⁰³ On 24 July, the keel of the first unit was laid down. Due to the need for secrecy the usual ceremony was cancelled. Two months later, on 24 September the keel of the second unit was also laid down. Work on the first unit progressed well despite the constant minor modifications of the plans, but the delays of some subcontractors, Witkowitz among them, foreshadowed the exceeding of the time limit. Škoda also informed the Navy that the delivery of the 30.5

guns of the first unit would be delayed by a few months.²⁰⁴

After the delegations had voted in favor of the extraordinary credit the Navy could officially sign the contracts on all the four battleships. The Navy signed the contract with the Danubius on 20 April 1911 on the *Schlachtschiff VII*. Four days later, on 24 April the Navy signed the official contract with the STT on the *Schlachtschiff IV, V* and *VI*. The time limits of the delivery of the STT ships were 1 July 1912, 1 January 1913 and 1 January 1914.²⁰⁵

As the launch date of the first unit approached, the process of naming the ships was started. In the first time of the history of the Navy the proposals were presented to the Military Chancellery of the Heir of the Throne instead of to the Military Chancellery of the Emperor, but the Emperor retained his right to approve the proposals. On 8 March 1911, the Navy presented its proposal to the Military Chancellery of the Heir of the Throne which contained the following names: *IV Tegetthoff*, *V Don Juan*, *VI Prinz Eugen* and *VII Hunyadi*. The Navy added that the rumors in the press that the name of the first unit would be *Franz Joseph* were baseless. Franz Ferdinand answered that he approved the name *Tegetthoff* for the first unit, and



31 *The launch of the Tegetthoff on 21 March 1912*

there was no urgency about the names of the other three units. However, on 22 March the Military Chancellery of the Emperor informed Montecucoli that the Emperor exercised his right for naming warships and he would give a name to the first unit. On 28 March, Franz Joseph named the *Schlachtschiff IV* after his personal motto *Viribus Unitis*.²⁰⁶

Despite the initial problems, the construction of the *Schlachtschiff IV* progressed well. In March 1911, the date of the launch was fixed as 24 June 1911. Eleven months after the keel laying, on 24 June 1911 at 9:10 a.m. the first dreadnought of the Austro-Hungarian Navy, the battleship *Viribus Unitis* was launched in Trieste. The sponsor was Archduchess Maria Annunziata, the half-sister of the Heir of the Throne. Among the participants beside Franz Ferdinand were the three common ministers, four Austrian and three Hungarian ministers. The 6/1911 issue of the "Die Flagge" was published as special "Dreadnought Number" on this occasion.

On 23 October 1911, the Military Chancellery of the Heir of the Throne informed the Marinesektion that Franz Ferdinand wished to give the names *Tegetthoff* to *Schlachtschiff V* and *Prinz Eugen* to *Schlachtschiff VI*. In 1912, the Emperor approved the two name proposals. In 1912 the Navy named the class after the second unit (*Tegetthoff* class, in the official documents Typ *Tegetthoff*).²⁰⁷ Because there was no official explanation, the motivation behind this decision is still unclear. It may have been a message to Italy in the naming the first Austro-Hungarian dreadnought class after the victor of Lissa. There is another possible explanation: perhaps the Navy wanted to flatter Franz Ferdinand because the Heir of the Throne had wanted to give the name *Tegetthoff* to the first unit of the class.

In October 1911, Franz Ferdinand expressed his wish via his Military Chancellery for a separate suit on the *Viribus Unitis* for himself inspired by the German example. The German Kaiser, Wilhelm II had an own suite on the standard battleship *Deutschland* and on one unit of every dreadnought class. In the spring of 1912, the Navy made the conversion for 82,000 Kronen.²⁰⁸

The works on the *Viribus Unitis* progressed well but due to the great delays of some subcontractors it was clear that the original building time would not to be kept. On 18 September 1912, on her 2 hours full power trial the *Viribus Unitis* attained an

average speed of 20.49 knots and 20.76 knots maximum for a short period while her machinery produced 27,383 SHP.²⁰⁹ Although on the basis of the preliminary calculations the Navy had expected a speed over 21 knots,²¹⁰ the *Viribus Unitis* easily exceeded the contracted speed of 20 knots. The first dreadnought of the Austro-Hungarian Monarchy was commissioned on 6 October 1912 at 2 p.m. under the command of Linienschiffskapitän Anton Willenik. The *Viribus Unitis* was the first commissioned dreadnought of the Mediterranean and the World's first battleship in service with triple turrets. On 7 October, the Österreichische Flottenverein presented a special ensign (Ehrenflagge) to the ship, which was ceremonially hoisted to the mainmast on the order of the Flotteninspektor, Vizeadmiral Anton Haus. While the ship had been commissioned two months earlier, the Navy did not officially take command over her until 5 December 1912.²¹¹

During the trials of the *Viribus Unitis* some problems developed. The heavy superimposed triple turrets made the ship top heavy, with her center of gravity being determined as 1.79 m over the waterline.²¹² When the ship turned at full speed with maximum rudder angle (35 degrees), she listed by 8.3°. The list of her STT-built sisters was even greater (*Tegetthoff* 11.3°, *Prinz Eugen* 10.75°). As a solution, the Navy ordered that the maximum rudder angle would be no more than 20° aside from slow speed maneuvers.²¹³ However, this was not an isolated case among battleships and battlecruisers with superimposed turrets. For example, the list of the German battlecruiser *Derfflinger* was 8° when she turned at full speed.

There was also a problem with the capacity of the Yarrow-boilers. The engineers of the STT optimistically counted the steam consumption of the Parsons-turbines at 7 kg/HP but it turned out that the real consumption was 8 kg/HP. In consequence of this the STT built ships could maintain their full speed only for two hours instead of for eight hours. After two hours the steam pressure dropped.²¹⁴ On 24 May 1915, on the way back from the Bombardment of Ancona the *Viribus Unitis* could maintain only 17.5 knots despite every effort of the stokers and the shutting down of such auxiliary steam consuming systems like the firewater pipeline.²¹⁵

When the *Viribus Unitis* was docked, deformations were detected in the structure of the double bottom under the aft gun turrets. A report dated on

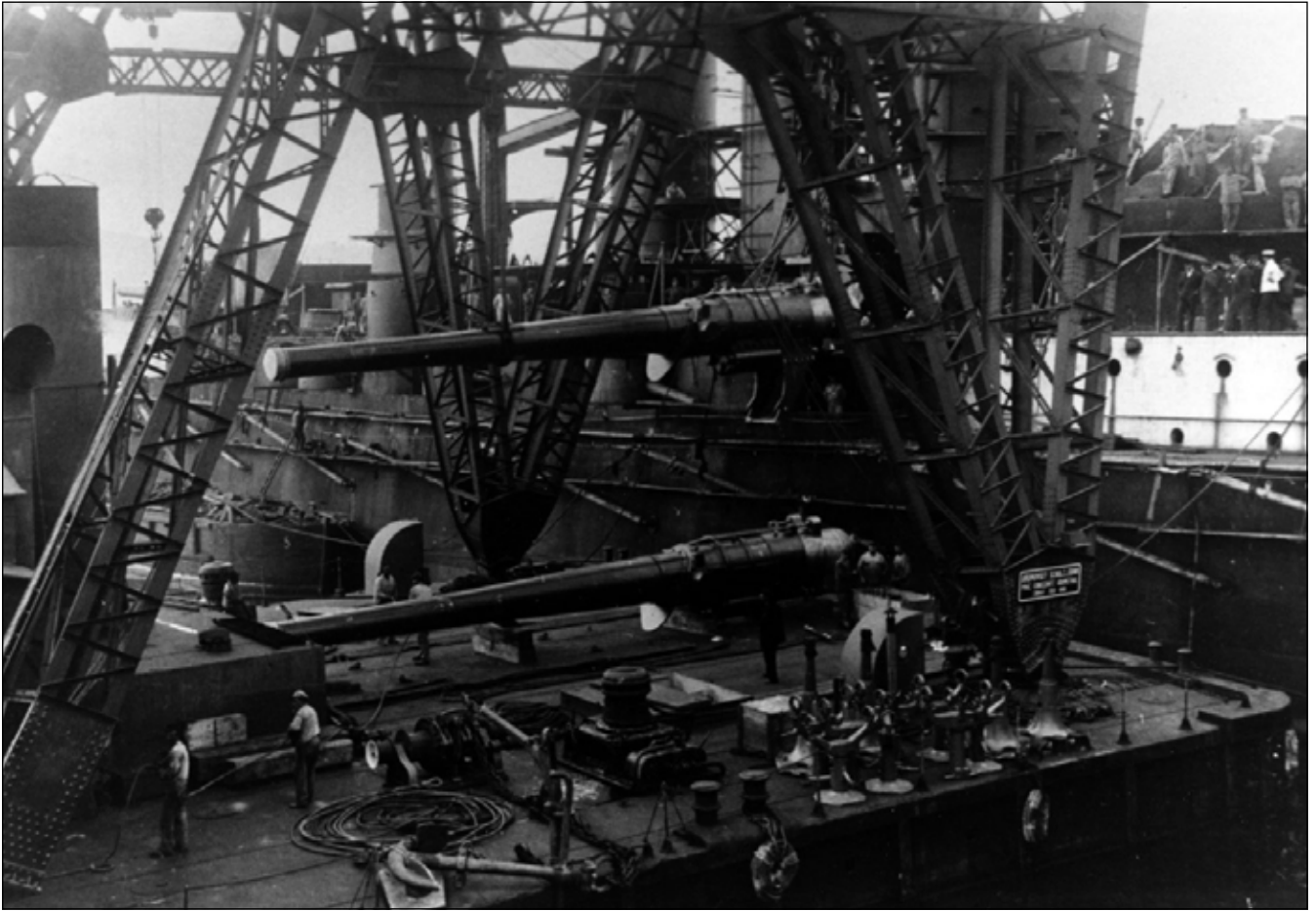

32 *Viribus Unitis* getting one of her 30.5 cm guns installed

2 October 1912 stated that the deformations had been caused by the docking itself.²¹⁶ During the installation of the gun turrets it turned out that the armored cupola of the rangefinder of the fore superimposed turret – the installation of the turret rangefinders was one of the modifications ordered by the Navy during the building of the ship – blocked the forward view from the conning tower so it had to cut new slits above the original ones.²¹⁷ There was a little debate between the Navy and the STT about the contracted displacement, the Navy stated that the shipyard had exceeded the displacement by 66 tons while the STT accepted only 12 tons.²¹⁸

During firing trials of the 30.5 guns the ship was damaged in fourteen locations. Among others the conning tower, the foredeck, the boats and the funnels were damaged, and the cost of the repair work exceeded 1,500 Kronen.²¹⁹

The building of *Schlachtschiff V* was much slower, because the majority of the workers of the STT worked on the first unit. Due to the slow works, STT had to postpone the date of the launch from December 1911 to March 1912. On 21 March, at

10:40 a.m. the *Tegetthoff* was launched in the presence of the Heir of the Throne, Franz Ferdinand. The sponsor was Archduchess Blanca, the wife of Archduke Leopold Salvator. The progress of works was slow, even after the launch. On the request of the STT the date of the delivery was postponed from 1 January 1913 to 16 April 1913. Due to a series of turbine problems the STT could not keep even this time limit. On 25 April 1913, on her 2 hours full power trial the *Tegetthoff* attained an average speed of 20.31 knots while her machinery produced 25,638 SHP.²²⁰ The *Tegetthoff* was commissioned on 14 July 1913 under the command of Linienschiffskapitän Franz von Holub.²²¹

The keel of the *Schlachtschiff VI* was laid on 16 January 1912 in the STT on the slipway which had been freed after the launch of the *Viribus Unitis*. The battleship *Prinz Eugen* was launched on 30 November 1912 at 11:30 a.m. The timespan of ten and half months between the keel laying and the launch was an absolute record in the history of Austro-Hungarian battleship building. The sponsor was Archduchess Maria Christina. Six days before

the launch Franz Ferdinand revoked his participation on the launch and ordered that the ceremony should be modest.²²² After the launch the work on the *Prinz Eugen* slowed down. In August 1913, it was estimated that the ship would be completed in March 1914 but later it proved to be too optimistic. On 14 May 1914, on her 2 hours full power trial the *Prinz Eugen* attained an average speed of 20.41 knots while her machinery produced 27,183 SHP. The third Trieste built dreadnought was commissioned under the command of Linienschiffskapitän Johann Graf von und zu Firmian on 8 July 1914. The Navy took on her on 17 July 1914.

The Trieste built sisters had several modifications during their career, but these were only minor improvements. These ships were not perfectly identical as there were minor differences between them, for example, in the form of the large air vent of the machinery room or in the form of the caps of the boat cranes.²²³ The first three units of the *Tegetthoff* class originally had torpedo nets imported from Britain. The fourth member, the *Szent István*, was commissioned without torpedo nets, because after the outbreak of the war it was now impossible to import torpedo nets from Britain. In 1917, torpedo nets and their booms were removed from the STT built units of the class. This was done because German experiences of the Battle of Jutland/Skagerrak showed that a hit on the net could detach it which posed a threat to the screws. As mentioned previously, the first two units of the class originally had no couplers in their gun turrets; these were added in 1913/1914. During the war the metal lids of the turret gunports were replaced with blast bags. Also, during the war *Viribus Unitis*, *Tegetthoff* and *Prinz Eugen* were armed with four 7 cm/50 AA guns²²⁴ which were mounted on the roofs of the superimposed gun turrets. With the improvements on the fire control equipment, we deal not here because this topic is discussed in detail in the last chapter of this book. After the outbreak of the war pieces of old torpedo netting on metal frames were fitted over the funnel caps for providing some protection against aerial bombs. *Viribus Unitis* and *Tegetthoff* were originally painted in the “Montecuccoligrün” (olive green) livery. In July 1914, both ships were painted in the new “Hausblau” (light grey) livery. *Prinz Eugen* was commissioned painted light grey. After the outbreak of the war gun turret and conning tower roofs were painted dark grey.²²⁵

On 8 April 1916, the Marinesektion ordered the commanders of the four *Tegetthoff* class battleships to write a report on their ship and to make recommendations for future battleship building. The reports were written in the summer and fall of 1916. The report on the *Viribus Unitis* was the most detailed and well written among them.²²⁶ In this chapter we deal with the reports on the three Trieste built ships.

The report on the *Viribus Unitis* bore the date 2 July 1916. In the introduction the ship’s commander, Linienschiffskapitän Kamillo Teuschl, established that he could write only of experiences of the everyday routine of the ship because there were no real combat experiences. He stated that the time of clearing for action was too long and the ventilation of the ship was insufficient in general.²²⁷ He stated also that the spaces for the officers, NCOs and men were too small and the ship was more cramped than the older battleships. The galley of the crew was too small and there were too few toilets for the crew.²²⁸

Teuschl considered the torpedo tubes in the bow and the stern absolutely useless. He proposed that the aft turbine-driven dynamos be given an auxiliary condenser. He felt it necessary to obtain batteries for the telephones and electric bells as auxiliary power supply sources. He pointed out that there was no central control position for the drainage and that the communication devices of the drainage control positions were incomplete, having not been installed between some positions during the building of the ship. The flooding time of the main magazines was sixteen minutes which he considered unacceptable.²²⁹

There was an unprotected slot between the barrette and the gunhouse – this was also mentioned in the other three ships’ reports. The deck fittings hindered the free movement of the empty cases ejected from the turrets, particularly in the case of the turret No IV (the lower aft turret). The overly large and thinly armored cupolas for the rangefinders on the turret roofs imposed the danger that an otherwise ricocheting projectile could peeled back the thin turret roof armor. To cap it all, the turret rangefinders were found to be useless.²³⁰

The next part of the report is the most quoted but also maybe somewhat misinterpreted. On the basis

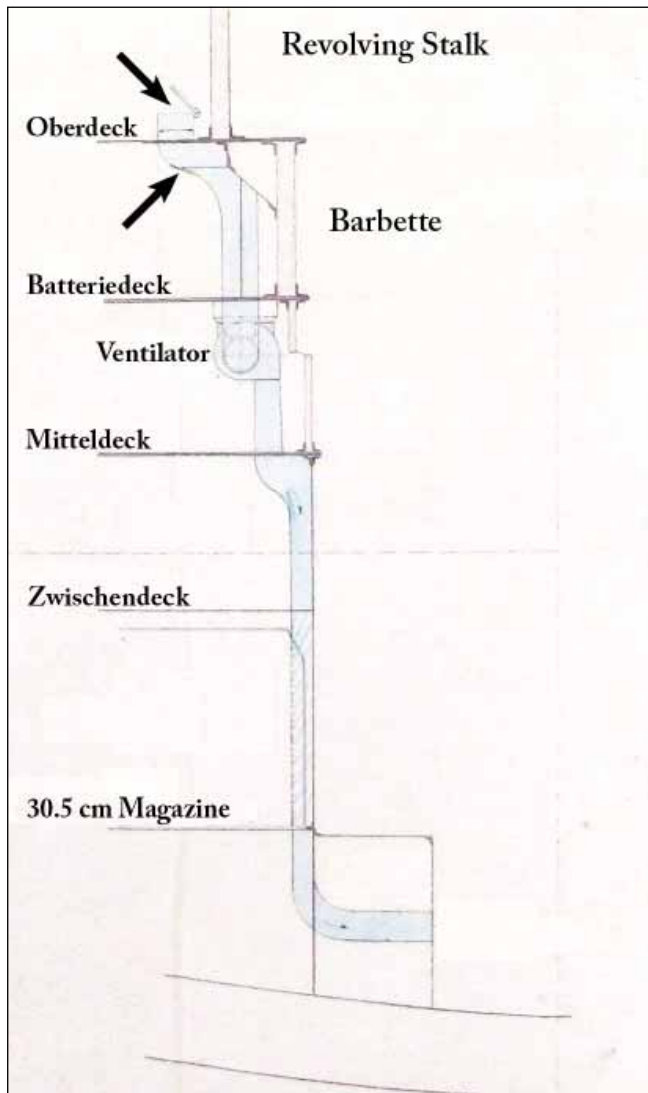

33 The turret ventilation system of the Tegetthoff class battleships. The two arrows indicate the two inlets

of this part of the report many printed and online publications question the combat value of the whole class, stating that the triple turrets became uninhabitable under battle conditions after a short time due to the lack of ventilation. The ventilators of the gun turrets sucked the fresh air from the Oberdeck (upper deck). The report writes that under battle conditions these air vents on the Oberdeck were closed to avoid the sucking in the propellant gases which had the following consequence: “after a short time the oil lamps burned no more due to the shortage of oxygen.” The ventilation of the gun barrels was also insufficient. Beside this paragraph there is a great S. O. S. and a handwritten remark: “Can it somehow be repaired yet?” There is also a large checkmark.²³¹ The latter means either that the Navy could find some solution, or after a closer examination, they found out that the flaw was not necessar-

ily in the ventilation system. Linienschiffskapitän Edmund Grassberger, who commanded the *Viribus Unitis* at the time of the Bombardment of Ancona, in his report did not mention any problem with the turret ventilation.²³² In their 1916 reports the commanders of the other three units also did not mention such a serious problem.

In fact, the closing of the air vents on the Oberdeck of the turret ventilation did not mean the shut-down of the ventilation itself. In the Plansammlung of the Kriegsarchiv in Vienna there is an original STT plan of the turret ventilation system. The 50 cm diameter air duct of the ventilation ran down from the Oberdeck outside the barbette to the underside of the lowest part of the revolving stalk of the turret joining it in the axle of rotation. This air duct had two closeable inlets, one on the Oberdeck at the base of the barbette not far from the centerline of the ship. The second inlet was one level below, on the Batteriedeck, and when the inlet on the upper deck was closed by a watertight lid the system was sucking the air from here.²³³ The ventilator of 3 cubic meters per second capacity was on the Mitteldeck, one level below the Batteriedeck. The operation of the turret ventilation was the following: the large ventilator pressed the air into the bottom of the revolving stalk, while in the gunhouse the three gun barrel ventilators were running, sucking out air and the propellant gases out of the gunhouse. The difference of air pressure between the bottom of the stalk and the gunhouse helped the circulation of fresh air throughout the mounting.

There is another document dealing with the turret ventilation: the report on the overheating of gun turret No III of the *Szent István* which is dated 9 September 1916. From this report we know that in bad weather or during firing the air vents on the upper deck were closed but the ventilation was not shut down as it sucked in air from the Batteriedeck as described above, so the system was the same as on the STT built ships. In the case of the gun turret No III of the *Szent István* the cause of the problem was that the air duct of this turret was too close to a heat source and warmed the air going into the duct.²³⁴

Teuschl in his report considered insufficient the end on fire capacity of the 15 cm guns and unsatisfactory the handling of the empty cases in the 15 cm battery. In his opinion the voice pipes and cables in the battery were too vulnerable. The in-

sulation of the bulkheads of the 15 cm magazines was insufficient. He wrote that there were places where the magazine walls were so hot that they could not be touched by bare hands. The cooling of the magazines was also insufficient, especially in summer when one of the two refrigeration plants cooled the provision rooms exclusively. He considered the 7 cm guns useless against the modern destroyers and torpedo-boats and he proposed that they be replaced by 9 or 10 cm guns.²³⁵

Teuschl considered the conning tower unnecessarily high and the 150 mm armor of the lowest two levels and the thin floors to be too weak. He stated that a hit on the lower part of the conning tower would have catastrophic consequences. Beside this line in the report there is a handwritten "True". The situation in the case of the aft conning tower was even worse because its understructure was only 15 mm thick.²³⁶

On the machinery, a separate comprehensive report was written. This report refers to two earlier reports on the machinery which are not found in the file. The existing report contains only proposals of minor importance. Every commander condemned the fact that there were no armored gratings in the funnels and considered that the emergency exits of the boiler and machinery rooms to be too narrow.²³⁷

The commander of the *Tegetthoff*, Linienschiffskapitän Franz von Holub, started his report with a mention of the cramped conditions. He proposed not to cut doors in the watertight bulkheads on the future battleships. These watertight doors had been sealed at the outbreak of the war, so they were unusable but still weakened the structure of the bulkheads. He considered the torpedo protection insufficient. He proposed to remove the torpedo nets considering their weight and questionable value. As the other commanders, Holub considered the ventilation insufficient. As every commander, he mentioned the unprotected slot between the barrette and the gunhouse. He also considered the 7 cm guns to be useless and he proposed 9 cm guns be substituted.²³⁸

The commander of the *Prinz Eugen*, Linienschiffskapitän Johann von und zu Firmian, point-

ed out that the armament of the ship was too heavy for the displacement. The units of the class were bow heavy and had low freeboard. He considered that an unlucky hit at the bow could be disastrous for the ship. He proposed for the future battleships be given a raised forecastle deck and omitting the heavy ram. He also considered the underwater protection insufficient and condemned the doors cut in the watertight bulkheads. He considered the ventilation insufficient and proposed to move the air vents to other places because the ventilation easily could suck in smoke. He proposed to solve the operation of the DC ventilators by utilizing AC, so that the ships in harbor could use the normal electric net instead of running their dynamos.²³⁹

Firmian also mentioned the slot between the barrette and the gunhouse. He considered the armor of turret roofs too thin and he proposed to reinforce them. He proposed also to interchange the magazines of the 30.5 projectiles and the 30.5 cm cartridges. He questioned the ability of the main magazine bulkheads to withstand the water pressure when the magazines had to be flooded. He considered the 7 cm guns useless and he proposed 9 cm guns instead of them as had the other commanders. He considered the bow and the stem torpedo tube useless for a battleship.²⁴⁰

The greatest critic of the *Tegetthoff* class was Admiral Alfred von Tirpitz. As it was mentioned previously, in April 1909 he strongly criticized the thin armor and the layout of the torpedo protection system of the Austro-Hungarian battleship design which Koudelka showed him. Tirpitz also often criticized these battleships later, mainly because their supposed weak survivability. Even in the fall of 1913, he made critical remarks on the first dreadnought class of the Dual Monarchy.²⁴¹

By these reports emerges a battleship which had many design flaws, which was over armed for her displacement, which was unstable and unseaworthy and which had a flawed torpedo protection system. This battleship was also cramped and had many ergonomic issues. The Navy was well aware most of these problems even when the ships were still under construction and tried to avoid them during the design process of the next battleships.

THE S. M. S. SZENT ISTVÁN

THE HUNGARIAN DREADNOUGHT

On 17 January 1914, at 10:50 a.m.²⁴² on the great csatahajó-sólya (battleship slipway) No 1 in Fiume-Bergudi, greased with tons of soap and lard, the 13,000 tons mass of steel of the former *Schlachtschiff VII* slowly began to slip into the sea as the large hydraulic pusher set the 152 meters long hull in motion. The two canvases on the bow which covered the ship's name were released and the red-framed golden letters proudly announced the name of the new battleship: *Szent István*. A few moments later, a tragic accident occurred: when both of the two bow anchors were dropped to stop the ship, the chain of the starboard anchor, which was not properly shackled, came loose and seriously injured two men on the foredeck. Two days later one of the men, the boatswain employed by the shipyard named Josip Pliskovac, died in the hospital. The other wounded man, Ermenegildo Picco, lost one of his legs. Despite this accident, this day was a great day for the Hungarian industry, especially for the young naval shipbuilding industry. At the time of the launch of the first (and only) Hungarian-built battleship, it seemed that there was a bright future ahead of the Ganz and Co. Danubius shipyard of Fiume as the lucrative contract for two more battleships was within reach, perhaps before the end of 1914. The events of history a few months later turned in a less favorable direction. The outbreak of the First World War soon resulted in the cancellation of the new battleships and four years later, in October 1918, the short history of the Hungarian naval shipbuilding came to an end.

The 20,000 ton, 152 meters long battleship *Szent István* was doubtlessly a credit to the record performance of the Hungarian shipbuilding industry. She was five times greater than the second largest Hungarian-built ship. Despite her flaws, *Szent István* was the symbol of the performance of the Hungarian industry and the equality of Hungary in the Austro-Hungarian Monarchy. This idea reflected in the name of the battleship: Stephen I (1000-1038) also known as Saint Stephen (*Szent István*), was the founder of the Hungarian State and the first Christian king of Hungary.

The battleship *Szent István* was an unlucky ship to some observers. Superstitious seamen believed that the death of Pliskovac doomed the ship. Their pessimistic attitude could only have been confirmed when on her very first mission on 10 June 1918; she was torpedoed and sunk by an Italian motor torpedo boat.

The Ganz and Co. Danubius Shipyard in Fiume

The long struggle of Hungarian politics for obtaining greater share from the industrial orders of the Austro-Hungarian Navy began in the early 1890s simultaneously with the rapid development of the Hungarian industrial capacity. A decade later, the Army and the Navy had to take the Hungarian demand seriously when in 1903 a decision was made to strengthen the common armed forces of the Empire. To achieve this goal in the special political system of the Dual Monarchy, the Hungarian politicians and delegation had to be won over to vote the much larger military budgets. It is worth noting that Prime Minister Count István Tisza lobbied in 1903-1904 harder than his predecessors. The development of the common armed forces was of vital importance for the Austrian and Hungarian heavy industry, because the economic crisis of the first years of the twentieth century made the profitable military orders more and more important for them.

In 1903, the Hungarian government signed an agreement with the common Army on industrial orders and in 1904 a similar agreement was signed with the Navy. The main point of these agreements was the understanding that the share of Hungarian industry in the industrial orders for the Army and the Navy would reach the Hungarian Quota (34.4 percent at that time). Because Hungarian industry was less developed than the Austrian-Czech industry, a compensation scheme was a very important part of these agreements. Compensation meant that if Hungarian industry could not manufacture a specific product and all of these products were or-

dered from Austria the Army or the Navy should order other products from the Hungarian industry exceeding the Quota. These agreements were under the constant attack by the Austrian politicians from the very first moment, so it was evident that they had to be revised. The occasion came in 1906, after settling the Hungarian political crisis of 1905. The new agreement collectively regulated the industrial orders of the Army and the Navy and it was signed by the Austrian and Hungarian governments and by the common Ministry of War. This agreement was less favorable for Hungary than the agreements of 1903 and 1904.²⁴³

Hungary, having paid a share proportion, the so called Quota, of the budget of the common Army and thus the Navy (31.4-36.4 percent), practically did not get any industrial orders from the Navy before the 1890s, except Whitehead torpedoes. In 1893, Hungarian delegation had its first claim on the Navy giving Hungary more orders.²⁴⁴ At the same time, members of Austrian delegation began to call upon the Navy to give more orders to the Austrian industry. While in Austria, thanks to the growing naval orders, the situation seemed to be satisfactory, in Hungary, although it had positive consequences, no fundamental changes occurred during the following years. Having seen the situation grow worse, the Hungarian delegation passed a resolution in 1897 that demanded that the Navy should give its orders to the two parts of the Austro-Hungarian Monarchy in proportion to their share of the budget financing.²⁴⁵ For example, in 1897, while having paid a budget share of 31.4 percent, only 12.3 percent of the Navy's industrial orders were given to Hungary.²⁴⁶

Hermann von Spaun, the new Marinekommandant, had the fleet's intensive improvement in view, but his program failed in 1898 owing to the resistance of Hungarian politicians. Spaun understood that Hungarian politicians, hostile to the increase of the Navy's budget, needed to be won over to his future plans. The only possibility was to meet the Hungarian requirements to some extent. In August 1898, Spaun made a written promise that the Hungarian industry's share in the Navy's orders in the future would be in proportion to their budget quota.²⁴⁷ The main problem lay in the fact that the promise, due to the underdeveloped nature of Hungarian industry, could not be kept. Despite the promises, the rate of the orders had not in-

creased essentially until 1900.²⁴⁸ In that year both the Hungarian government and the Hungarian delegation put greater pressure on the Navy, with the Hungarian government uttering veiled threats that they would vote down the budget.²⁴⁹ As a result, spending growth began soon afterwards; in 1904 the share of the Hungarian industry reached 21.48 percent when the Hungarian Quota was 34.4 percent.²⁵⁰

The opportunity to conclude a formal agreement between the Navy and Hungary came in 1904. In that year Spaun requested the delegations to vote an extraordinary credit of 120 million Kronen. Before the meeting of the delegations, the Hungarian Prime Minister, Count István Tisza made clear what he wanted in exchange: a bilateral agreement on the share of the industrial orders of the Navy.²⁵¹ In June 1904, a week after the vote for the credit, an agreement between the Navy and the Hungarian government was reached. This agreement regulated the divisions of the orders of the Navy in 14 articles. The agreement provided compensation for Hungary in certain cases, in return for Austrian deliveries exceeding the Quota. The essence of the agreement was included in the secret clause promising destroyer and torpedo boat orders and a 50 percent rate of shell (later ammunition) orders to Hungarian industry. The secret clause was so secret that it was written by pencil only at the bottom of the last page.²⁵² While the new agreement of 1906 was less favorable for Hungary, the secret clause remained in force.²⁵³ With this agreement the Navy ensured that the Hungarian government and the Hungarian delegation's majority would support the further development of the fleet. The secret clause was the foundation of Hungarian naval shipbuilding by the Danubius Shipyard in Fiume.

In 1896, the unification of three formerly independent shipyards, backed by the Magyar Általános Hitelbank (Hungarian General Credit Bank), formed the greatest Hungarian-owned shipyard, the Danubius-Schoenichen-Hartmann Egyesült Hajó-és Gépgyár Rt. (D-S-H United Shipyard and Machine Factory Ltd) which was established in Budapest. The yard was renamed simply Danubius in 1906. In Fiume (Rijeka), which belonged to Hungary between 1868 and 1918, in 1904 three shipyards existed: The Whitehead, the Lazarus and the Howaldt and Co. The Hungarian



34 *The Danubius Shipyard in Fiume-Bergudi with Huszár class destroyers and Kaiman class torpedo boats under construction*

government considered these shipyards unsuitable for the role of being the new Hungarian great naval shipyard. The favorite was the Danubius, whose board of directors maintained good relations with the leading Hungarian politicians. The financial group behind the Danubius negotiated with the Navy on future orders. On 2 May 1905, a formal agreement was reached between the Navy and the Danubius, according to which the Navy undertook to order six destroyers and ten torpedo boats from the Danubius.²⁵⁴ In February 1905, the Navy ordered from the STT five destroyers of the *Huszár* class and thirteen torpedo boats of the *Kaiman* class. Once this agreement was reached, the Magyar Általános Hitelbank, the Danubius's largest shareholder, bought the Howaldt shipyard in Bergudi, the suburb of Fiume.

On 23 August 1905, the Danubius signed a contract with the Hungarian Treasury on building a modern shipyard in Fiume. The Hungarian State gave the new shipyard a territory of 10,000 square meters beside the former Howaldt shipyard

for 50 years free of charge. On 5 September 1905, Franz Joseph as King of Hungary sanctioned the contract,²⁵⁵ so this day became the symbolic birthday of the short-lived Hungarian naval shipbuilding industry.

On 29 November 1906, the Navy officially ordered six *Huszár* class destroyers and ten *Kaiman* class torpedo boats.²⁵⁶ The news of the contract caused great hue and cry in the Austrian delegation. At the 5 January 1907 meeting delegate Leopold Steiner questioned the ability of the Hungarian shipyard and the quality of its future products. Admiral Montecuccoli in his reply said in connection with the quality of the Hungarian ships "We hope for the best!" In response Steiner said "But with hopes no one can build ships!"²⁵⁷ The expansion of the Danubius Shipyard in Fiume to build these new ships was completed in February 1907 and the construction work on the first ships began in the spring of the same year.²⁵⁸

18 July 1908 was a great day in the history of the Danubius Shipyard: the first vessel, the torpedo

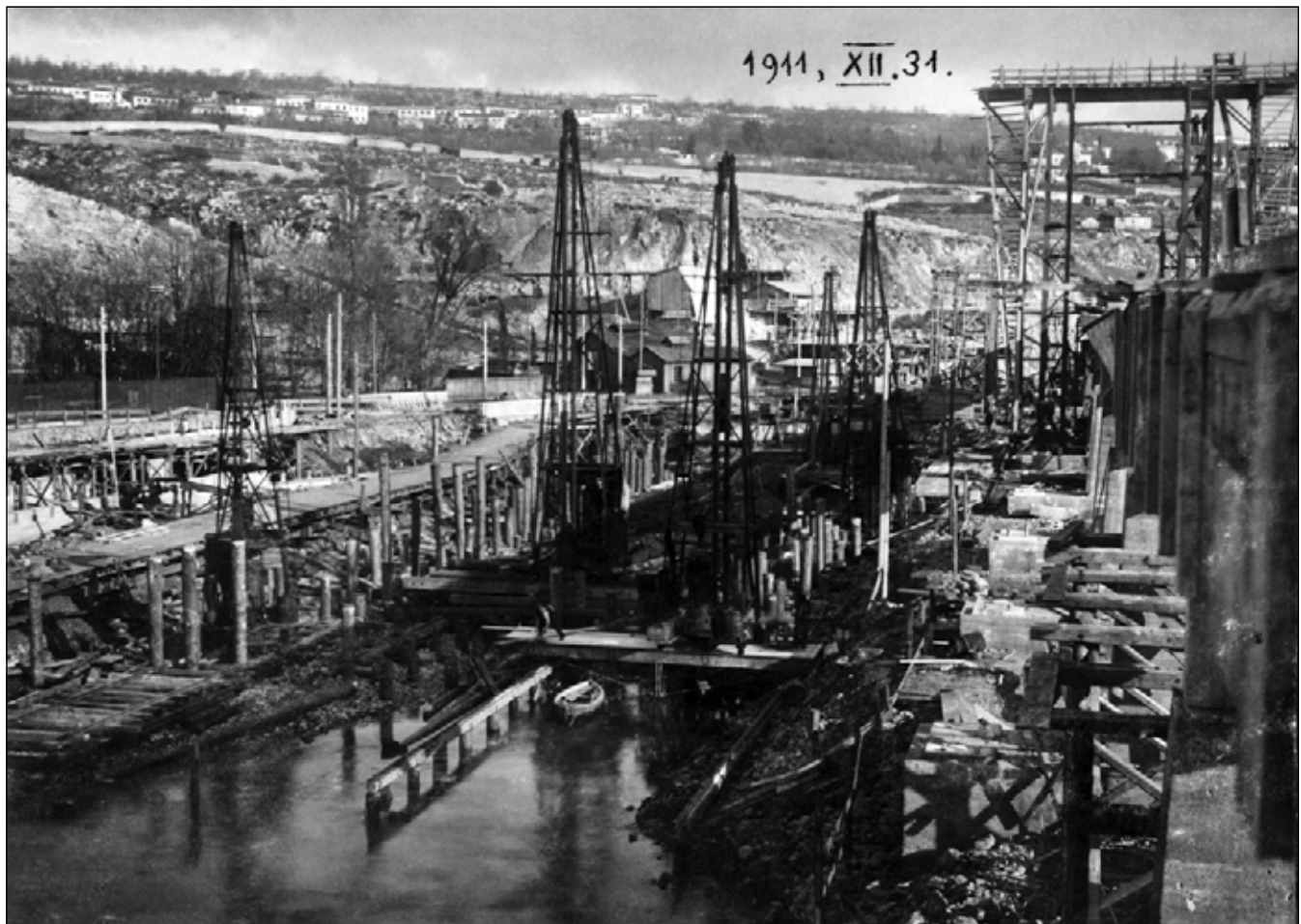

35 *The Ganz and Co. Danubius shipyard on 31 December 1911*

boat *Triton*, was launched on this day. The first destroyer, the *Turul* was launched on 9 August 1908. In March 1909, Korvettenkapitän Hermann Marchetti inspected the Danubius in Fiume. He wrote a rather negative report on the shipyard. He wrote of missing rivets in the watertight bulkheads and engine damages caused by careless workers.²⁵⁹ In a letter to the Navy the Danubius tried to rebut the statements of Marchetti, but at least a part of them was true.²⁶⁰ In 1908, as the last part of the modernization program of 1904 the Navy ordered twelve 110 ton coastal defense torpedo boats, four of them from the Danubius. Ordering only one-third of the boats from the Hungarian shipyard caused great indignation in the Hungarian delegation, which threatened the Navy with the rejection of the naval budget.²⁶¹ As a result of the strong Hungarian objection the number of the boats ordered from the Danubius was later increased to six. As the Hungarian political situation in 1910 precluded the extraordinary credit the Navy requested, Danubius was under threat of being left without orders. Thus,

the shipyard had to accept the order for the salvage steamer *Herkules* at a limited price of 1.075 million Kronen. The original offer of the Danubius for the building contest in 1909 was 1.275 million Kronen, the most expensive of all.²⁶²

When negotiations on the future dreadnought program began in 1909 between the Hungarian government and the Navy, it was clearly evident that the relatively small Danubius Shipyard was unfit for the new task of building large ships, especially a dreadnought. Once the Hungarian political crisis was past and as the date of a final agreement was drawing near, both the Hungarian State and the Danubius made many investments to increase the capacity of the shipyard. In 1910, the Hungarian Treasury bought a plot of land of 75,000 square meters from Whitehead and leased it to Danubius for a minimal sum. The Hungarian State Railways (MÁV) built a new line to the shipyard at its own expense. In 1911 the rocky cliffs around the shipyard were dynamited and the rubble laid down on the seabed to become the foun-

dition for new, broader slipways. Within a year and at a great expense, new workshops and two 265 m long and 35 m wide slipways of reinforced concrete (Battleship slipway No I and No II) were constructed. The territory of the shipyard reached 127,000 square meters in 1912, including the new embankments. It was evident too, that the capacity of Danubius's machine shop in Budapest²⁶³ was not sufficient for such a great order. In 1911, the Hitelbank initiated the fusion of the Danubius and the Ganz és Tsa Gépgyár (Ganz and Co. Machine Factory) under the name of Ganz és Tsa. Danubius Hajó-, Waggon- és Gépgyár (Ganz and Co. Danubius Shipyard, Railway Wagon and Machine Factory). This fusion created Hungary's largest industrial complex.

After the fusion the so-called Naval Machinery Department in Budapest switched over to autonomous machinery design instead of merely copying the plans of the Navy. To help that, the shipyard bought some licenses from Great Britain and Germany.²⁶⁴ The most important of them, the license of German AEG turbines was bought in October 1909.²⁶⁵ Beside these the Danubius had for a long time possessed the license to manufacture Babcock-Wilcox boilers.

On 13 December 1910, the MTK inspected the Danubius yard. The report of the MTK stated that the great slipways for battleships would be completed only in the spring of 1912. Considering that and the unprepared state of the Danubius, they stated that the building time of the battleship would be 42 months rather than 30 months prescribed by the Navy.²⁶⁶ In fact, the total building time of the battleship *Szent István* from signing the contract to the commissioning reached 55 months.

Beside the one battleship the Navy ordered from the Ganz and Co. Danubius two of the three 3,500 ton scout cruisers of the 1911 program, the *H* and the *I* which were later named *Helgoland* and *Novara*. According to the agreement of January 1911 all the six 800 ton destroyers (*Tátra* class) were ordered from the Danubius. These were the first ships not only built, but designed by the Hungarian shipyard. Originally all the 250 ton torpedo boats were to be ordered from the Austrian industry. The Navy increased the number of the boats from twelve to twenty-seven in February 1913. In the same year the Navy ordered sixteen torpedo boats from the Danubius, partly as a compensation

for the Hungarian industry because the submarines intended for Hungary were ordered in Germany. The total worth of these orders excluding the battleship was 41.1 million Kronen. This sum alone was more than twice the total worth of the Navy's orders given to Danubius between 1906 and 1910 (18.1 million Kronen).²⁶⁷ After the fusion of the Danubius with the Ganz and Co. in 1911, the annual reports of the Ganz stated that the shipbuilding branch was loss-making while the published production data were false. Most probably this served to conceal the huge profit of the warship building.²⁶⁸

The *Schlachtschiff VII*

When Korvettenkapitän Alfred von Koudelka, the secretary of the Marinekommandant, Admiral Montecuccoli, negotiated in November 1906 with members of the Hungarian government on the future dreadnoughts in Budapest, Commerce minister Ferenc Kossuth made clear that Hungary would assent to future dreadnought construction only if one third of the costs would be spent in Hungary and one of the battleships would be built by the Danubius Shipyard. Hearing this news Montecuccoli allegedly cried out in his hotel room: "That ship will be never completed!"²⁶⁹ The prophecy of Montecuccoli almost came true, but at last she was completed well past the deadline.

To come to terms with Hungarian politics was a long process. The Navy had certain worries in connection with the quality of the Hungarian built ships, but the Hungarian dreadnought was a question of politics: she was the sine qua non of Hungary's vote for the whole class. The negotiations between the Navy, the Hungarian government and the Danubius Shipyard started in 1909 and lasted until the end of 1910. The Navy in July 1909 agreed with the Hungarian government on the principles: in exchange of voting the dreadnoughts and developing the Danubius at public expense, 50 percent of the orders for new vessels including one of the four battleships would go to Danubius.²⁷⁰

Once the Hungarian political crisis was past the Austrian and Hungarian delegations voted the 312 million Kronen extraordinary credit for the Navy in February and March 1911. After the vote of the delegations, the Navy finally could legally

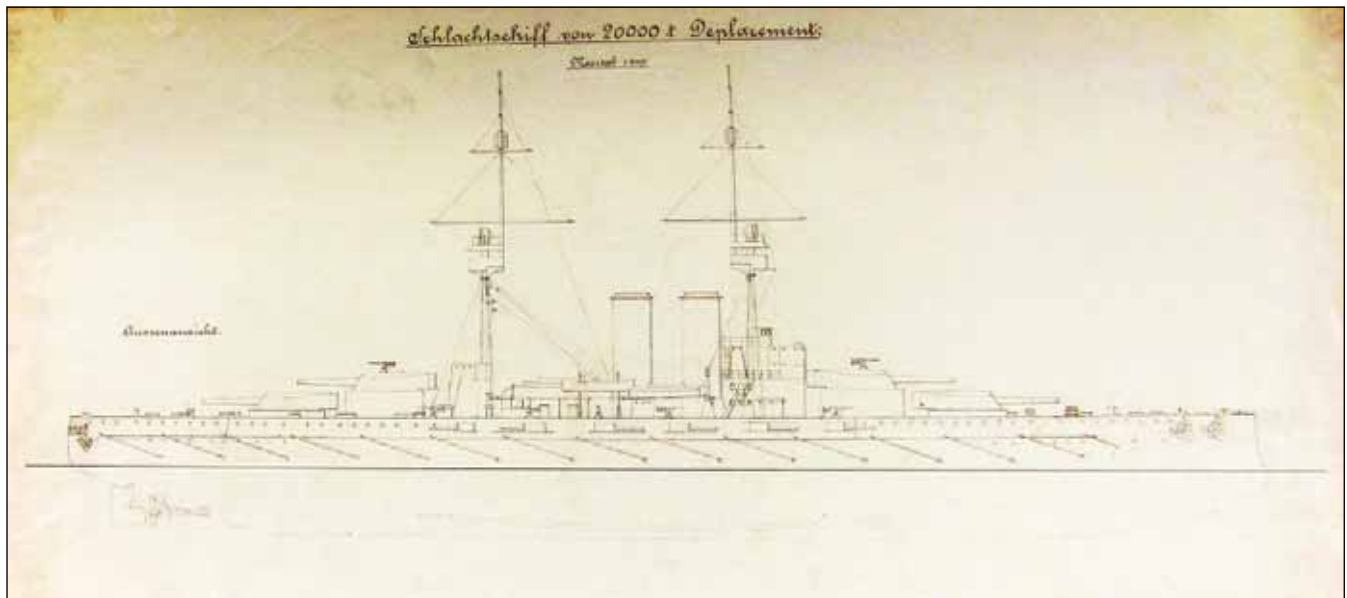

36 The Ganz and Co. Danubius design for Schlachtschiff VII from 1912

and officially sign the contract with the STT and the Danubius on the four battleships and on the other ships of the 1911 program.

The fourth member of the class of 20,000 ton battleships, *Schlachtschiff VII*, was intended to be built in the Hungarian shipyard. On 6 March 1911, the Navy asked the Danubius if they could build a battleship on the plans of the STT but with different machinery. A few weeks later, on 20 April 1911 the Navy and the Danubius signed the contract on the *Schlachtschiff VII*. The contract price of the hull was 14.5 million Kronen and of the machinery was 6.6 million Kronen. The time limit of the delivery was 10 July 1914.²⁷¹ The price of the complete battleship including armor, guns and ammunition was 60.6 million Kronen.

Originally the *Schlachtschiff VII* would have differed from her sisters in machinery only. The Danubius built the ship with Babcock-Wilcox boilers instead of Yarrow boilers and with AEG-turbines instead of Parsons-turbines. The Hungarian ship had only two screws, while the Austrian built ones had four. The Danubius argued that the twin screw arrangement would make the ship more maneuverable.²⁷² Otherwise each of the four ships had two sets of two-stage (high pressure and low pressure) turbines, on the Austrian ships each stage worked on its own shaft, while on the Hungarian ship the two stages of each set were coupled together in line and worked on one shaft. The Babcock-Wilcox boilers of the *Schlachtschiff VII* were heavier, but

superior and had greater efficiency than the Yarrow ones in that they could produce enough steam (200,000 kg per hour) for eight hours unlike the STT built Yarrow ones.²⁷³ The Babcock-Wilcox boilers were fitted also with superheaters, which the Yarrow boilers of the STT-built dreadnoughts lacked. The dynamos, the generators and the coolant pumps were manufactured by the Ganz Villamossági Rt. (Ganz Electric Ltd).²⁷⁴

The visible differences, which rendered it easy to distinguish the Hungarian dreadnought from her sisters, were ordered by the Navy after her launch. The ship was fitted a modified and enlarged searchlight platform over the bridge and around the funnels. This platform was copied from the 24,500 ton battleship design and the change order was given to the shipyard in February 1914. To clear this new platform, the two funnels had to be heightened by 1.5 meters. The armored fire control towers for the 15 cm batteries on the Oberdeck were traversed by 90 degree respective to the other ships' control towers, so they became more spacious and less exposed to enemy fire. This modification was proposed by Linienschiffsleutnant von Schwarz in early 1915.²⁷⁵

In the Plansammlung of the Kriegsarchiv Vienna there is a series of plans made by the Ganz and Co. Danubius in 1912. This version of the *Schlachtschiff VII* had some unique features which were not implemented on the ship as actually built. On the mast tops there were large fire control po-

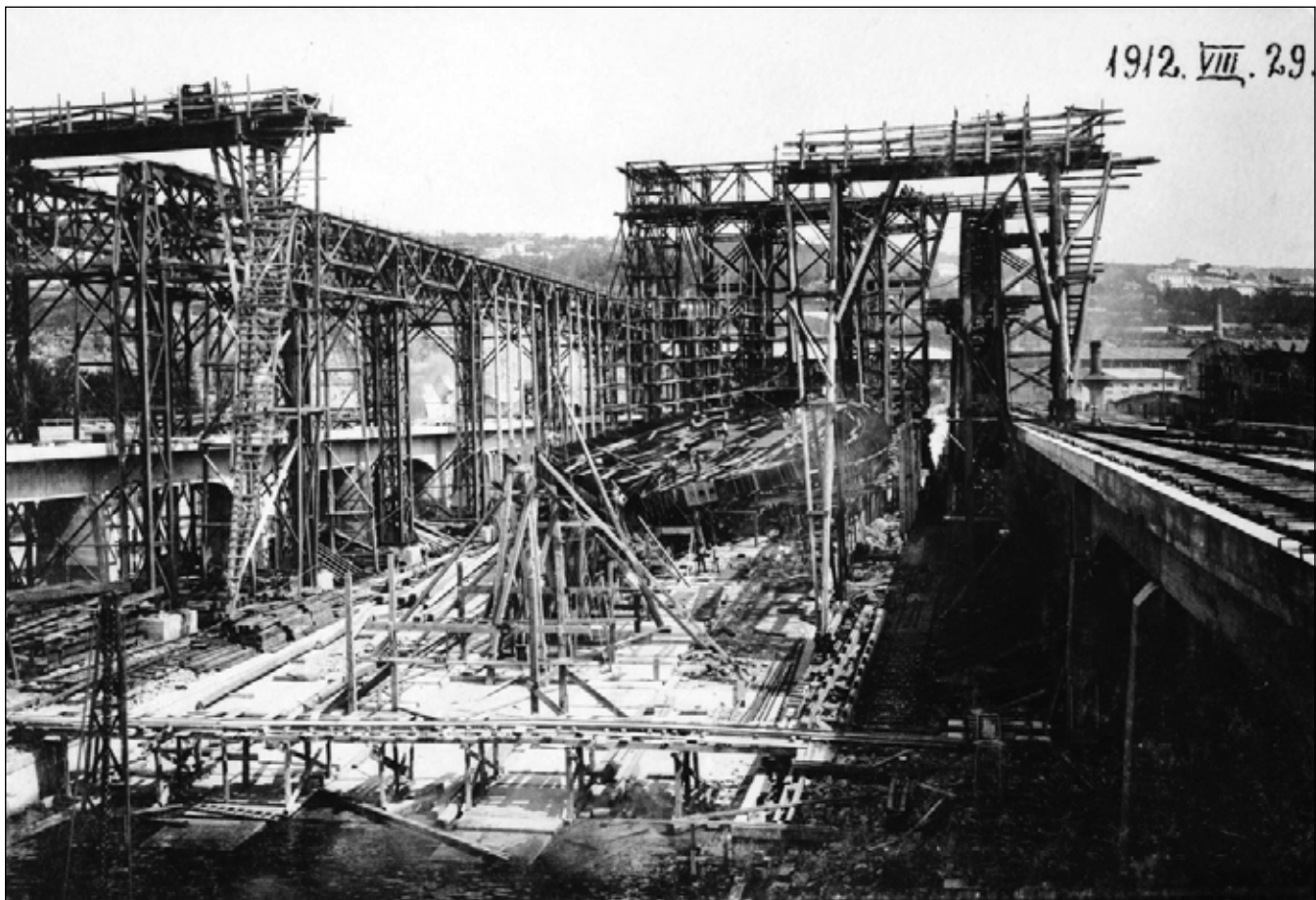

37 *The Schlachtschiff VII under construction*

sitions with a searchlight on the top of each one. Not visible from the outside, but a much more important difference was the lack of the bulkheads between the two magazines of the 30.5 cm turret groups compared to the Navy's/STT's plans. Obviously, the Navy considered the lack of these bulkheads to be a serious flaw and ordered the Ganz and Co. Danubius to build *Schlachtschiff VII* with these bulkheads. The drawings of the flooding calculations of battleship *Szent István* show the ship with these bulkheads.²⁷⁶

Due to the different shaft line arrangement the stern of the ship had to be redesigned and the propeller shaft bearings had to be reinforced. The Navy considered the shipyard's sizing calculations of the propeller shafts and bearings inadequate and the same applied to the calculations of these items for the cruisers and destroyers being built by Danubius. The Navy advised to use the Stodola method.²⁷⁷ This was the most important in the case of the *Schlachtschiff VII* because her propeller shafts were longer by 20 meters and heavier by 13 tons compared to the shafts for the STT built ships.

The Navy ordered to increase the shaft diameter from 380 mm to 410 mm and to strengthen the frames of the stern.²⁷⁸ The Danubius introduced a new, innovative method of lubricating the shafts: the closed system was comprised of a pump, a tank and a water cooling section. This system eliminated the danger of external contamination. This innovation impressed the Navy so much that they ordered this system to be fitted to the *Tegetthoff* and the *Prinz Eugen*.²⁷⁹

Unlike the other three units of the class, for the *Schlachtschiff VII* only the 30.5 cm guns were originally ordered from the Škoda in 1911. This was due to the intention of the Hungarian government to establish a Hungarian gun factory. In March 1911, the Hungarian Finance Minister László Lukács informed the common Ministry of War that the Hungarian government would establish a gun factory in Diósgyőr.²⁸⁰ Montecuccoli, contrary to the common War Minister Moritz von Auffenberg, was enthusiastic because he hoped that the Hungarian factory would break down the high prices of the Škoda. At the end of April, Linienschiffsk-

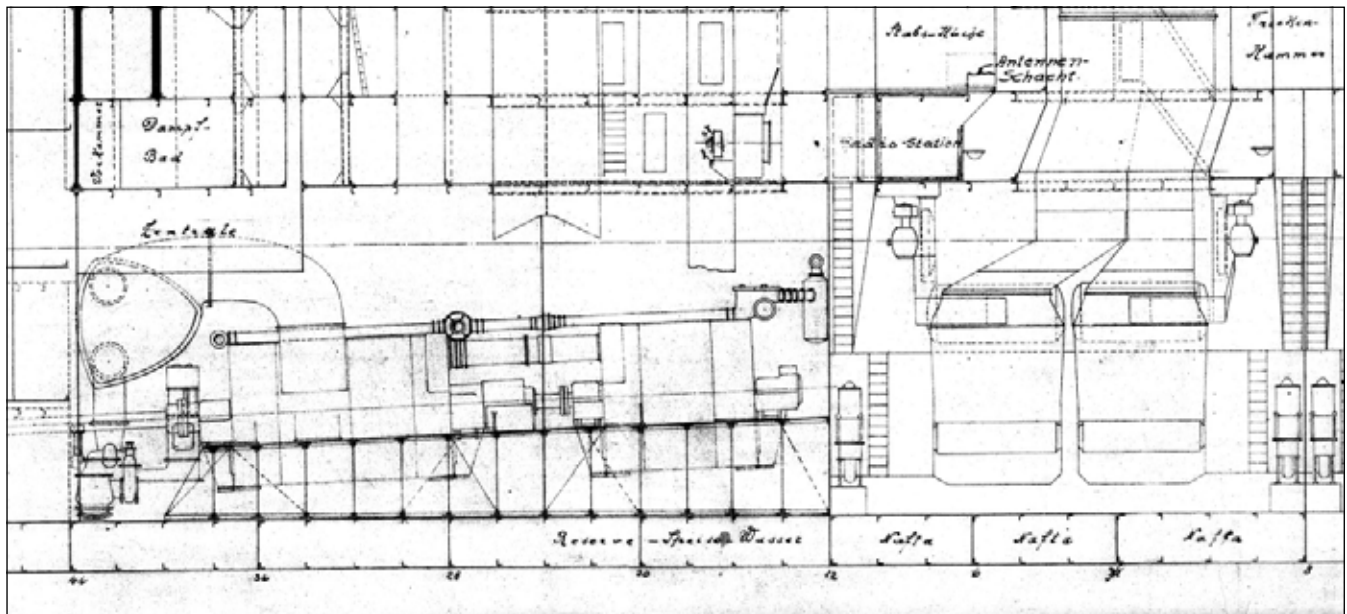

38 The turbine rooms and the aft boiler room of the Schlachtschiff VII

pitän Emil Fath, the head of the artillery department of the MTK, travelled to Budapest and negotiated with the directorial board of the Diósgyőr Ironworks and with Lukács. During these negotiations Fath was informed that the Hungarian government was planning to involve the British Vickers-Maxim in the establishing of the gun factory. On 18 May 1911, the Navy officially promised that the 15 cm and 7 cm guns for the *Schlachtschiff VII* would be ordered from the new factory if it could guarantee a delivery deadline of 1 April 1914.²⁸¹ Thanks to the strong opposition of the Heir of the Throne and the new common War minister, Alexander von Krobotin, the establishing of the gun factory in Diósgyőr with the participation of the Vickers-Maxim failed. The Hungarian government then started negotiations with Krupp in 1912. The Navy waited until 31 May 1912, but when on this date the agreement between the Hungarian government and Krupp still was not concluded, on 1 June 1912 the Navy ordered the 15 cm and 7 cm guns for the *Schlachtschiff VII* from the Škoda for 2,260,163 Kronen.²⁸² A little later the Krupp terminated the negotiations with the Hungarian government and declared the bargain off. The new Hungarian Finance Minister, János Teleszky, realized that he could not act against Krobotin who was vehemently lobbying for Škoda. Teleszky, despite his strong reservations against Škoda, agreed with the Czech firm on establishing a joint gun factory in 1913. The Magyar Ágyúgyár Rt. (Hungari-

an Gun Factory Ltd) was established in Győr, near Vienna in April 1913. The Hungarian government had controlling interests with shares of 7 million Kronen and Škoda had shares of 6 million Kronen. Although no guns were actually delivered to the Navy, gun production for the Army was started in July 1916 and until the end of the war the Hungarian Gun Factory manufactured 711 field guns and howitzers for the Army.²⁸³

From the first moment it was dubious that the Danubius could keep the delivery deadline for the battleship. In April 1911, when the contract on the *Schlachtschiff VII* was signed, the great slipway was only 10 percent complete and even in January 1912 it was still incomplete. The keel of *Schlachtschiff VII* was laid down on 29 January 1912. In consequence of the unsatisfactory working-stock of the yard, the lack of experience of the workers and the delays of the subcontractors, the building process was much slower than in the STT. An article in the Austrian newspaper "Neue Freie Presse" in January 1911 blamed the Navy for giving a battleship order to the Danubius and stated that the ship would never be completed. This article also accused the Danubius to allot the two thirds of the orders to Prussian firms.²⁸⁴ The Heir of the Throne reading this article pressed the Navy to restrict the material orders of the Danubius from abroad to special materials not available in Austria.²⁸⁵ In October 1912 Franz Ferdinand (who was notorious for his hatred of Hungarians) questioned the ability of the Danu-

bius and the quality of its ships. The Navy defended the yard in a letter to the Heir of the Throne, but he maintained his concerns.²⁸⁶

The construction process in the Hungarian yard was very slow compared to the STT. The keel of the *Schlachtschiff VI (Prinz Eugen)* was laid on 16 January 1912 in Trieste and she was launched on 30 November of the same year, so her construction time was ten and a half months. In the case of the *Schlachtschiff VII* this time was two years. Beside the lack of experience of the workers, strikes and great delays of the subcontractors, like Witkowitz, Schoeller and Wertheim, slowed the work on the ship. At the end of 1913, the ship was 60 percent complete. At this time, it was evident that the original delivery deadline could not be kept. The Bauleitung Bergudi (the board of the Navy which surveyed the works in the Danubius) proposed a new delivery deadline of 20 January 1915 instead of 10 July 1914.²⁸⁷

The Name Giving and the Launch

Due to the slow construction of the *Schlachtschiff VII* it became obvious in the fall of 1913 that the launch would be delayed nearly a whole year from the originally planned date. As was mentioned previously, in Austria-Hungary the process to choose the name for a warship under construction usually began a few months prior to the launch and to choose the name was the Emperor's right. In the years prior to the First World War the process was controlled by a regulation sanctioned by Franz Joseph in May 1898.²⁸⁸ Since 1908, the Navy sent its proposals to the Heir of the Throne, but even he had to approve his choice by the Emperor. Sometimes the Emperor exercised his right to choose a name on his own, for example in the case of the *Schlachtschiff IV*. Franz Ferdinand chose for this ship the name *Tegetthoff* but Franz Joseph told via his Military Chancellery that he named the ship after his personal motto *Viribus Unitis*.

Choosing the name for the Hungarian built battleship was a delicate matter. The Hungarian government had expressed its wish a few years earlier, when the case of the name giving of the preceding battleships had been at issue, to give a Hungarian name to one of them. In 1911, the Navy proposed the name *Hunyadi* for the Hungarian built ship, but Franz Ferdinand did not deal with it. In April

1913, the Navy sent the following proposals to the Heir of the Throne: *Corvin Mátyás*, *Szent István*, *Hunyadi* and *Erzsébet Királyné*. Franz Ferdinand rejected *Corvin Mátyás* and *Erzsébet Királyné* on the ground that these names would fuel the Hungarian separatism, and he rejected *Hunyadi* stating that there were living relatives of that family. In fact, he wanted a name which symbolized the unity of the Empire: *Laudon* after the 18th century Austrian General Ernst Gideon Freiherr von Laudon. When he informed of his choice Admiral Anton Haus, the Marinekommandant could not sleep all night because he knew that naming a Hungarian-built ship after an Austrian General would create a scandal and turmoil in Hungary.²⁸⁹ At last the old Emperor saved the situation. General Arthur von Bolfras, the head of the Military Chancellery of the Emperor calmed Haus and the Hungarians by telling them that the Hungarian ship would have a Hungarian name. Bolfras personally backed the name *Szent István* and he convinced the Emperor. In June 1913, Franz Joseph chose the name *Szent István* for the *Schlachtschiff VII*.²⁹⁰

The question of the sponsor (Taufpatin) was another delicate matter. Franz Ferdinand originally wanted the wife of Leopold Berchtold, the common Foreign minister, but his style ("Inevitable that the sponsor should be a Hungarian Lady") angered the Hungarians. Yet the Navy saved the situation declaring that the sponsor of a battleship could only be an archduchess of the Habsburg family.²⁹¹ The first choice of Franz Ferdinand was Archduchess Zita, but her husband (the later Emperor Karl) rejected it because the archduchess was pregnant (with Archduchess Adelheid). Finally, Archduchess Maria Theresia, the stepmother of Franz Ferdinand, together with her daughter accepted the task. She was an experienced sponsor. Her daughter, Maria Annunziata called off her participation a few weeks before the launch, in which Haus saw of the hand of the Heir of the Throne. Franz Ferdinand called off his participation on the launch in November 1913 which angered Haus because he felt, that the Heir of the Throne discredited pre-eminently the Navy.²⁹² In truth Franz Ferdinand was absent from the launch of the *Prinz Eugen* too, moreover, on that occasion he had banned the participation of large naval units, while on the launch of the *Szent István*, the dreadnoughts *Viribus Unitis* and *Tegetthoff* were present.



39 *Viribus Unitis*, *Tegetthoff* and the three *Radetzky*s in the Gulf of Fiume on 17 January 1914

The day of the launch was fixed in October 1913 to 17 January 1914. At the upper end of the slipway a grandstand was erected for the archduchess and the illustrious guests. Two separate smaller ones were constructed for the *Österreichische Flottenverein* and for the *Magyar Adria Egyesület* (Hungarian Adria Association). In the latter was exhibited the *Szent István* plaque, the present of the Association which was intended to decorate the wall of the admiral's saloon of the ship. On the launch the common government was represented by War minister Alexander von Krobatin, the Austrian government by the Minister of Landwehr Friedrich von Georgi and the Hungarian government by the Prime Minister Count István Tisza, Finance Minister János Teleszky and Commerce Minister János Harkányi. On the occasion of the launch two squadrons arrived at Fiume under the command of Vizeadmiral Millenik and Kontreadmiral Löffler. The dreadnoughts *Viribus Unitis* and *Tegetthoff* were also present. At 8 a.m. the gun salutes of the *Tegetthoff* signaled the beginning of the event.

The archduchess and her escort arrived at Fiume on the board of the admiral's yacht *Lacroma* and landed on the Adamich Mole at about 10:30 a.m. and they departed for the shipyard by automobile. In the Danubius Admiral Haus received

the archduchess and in a short speech he asked her to christen and launch the battleship. The speech of Maria Theresia had been previously censored by Franz Ferdinand who had cancelled the sentence which praised the Hungarian industry.²⁹³ At 10:50 a.m. after her short speech the archduchess pressed the electric button "Christening" and the canvases on the bow were released and a bottle of champagne was broken over the bow. After that, she pressed the button "Launch" and a hydraulic pusher put in motion the hull of the battleship. The illustrious guests and the crowd were unaware to the accident which was occurred during the launch where two workmen, Pliskovac and Picco were injured. After he learned of the death of Pliskovac, the Emperor donated 800 Kronen and the archduchess 400 Kronen to his widow.²⁹⁴

The students of the *Marineakademie* (Naval Academy) which was in Fiume and the students of the *Magyar Királyi Állami Tengerészeti Akadémia*, the "Nautica" (Royal Hungarian Marine Academy) were all ordered to participate in the launch. It's worth quoting how the students of the "Nautica" saw the launch: "Today was the launch of the 'Szt. István', the first dreadnought built in Hungary. At 8 a.m. we left for the yard; our legs were benumbed when finally, at 11 a.m. it



40 *The launch of the Szent István on 17 January 1914*

happened. All has gone smoothly, only the leg of one man was wounded by the anchor chain.”²⁹⁵

In the evening a party was given at the Governor’s Palace for the illustrious guests. During this event a congratulating telegram from the Emperor arrived which contained the phrase which had been cancelled by Franz Ferdinand from the archduchess’s speech.²⁹⁶ It was a great satisfaction for the Hungarian government and the representatives of the shipyard. Count Tisza asked Maria Theresia to read aloud the telegram and made publish it in the newspapers. On the order of Fiume’s Governor, István Wickenburg the port was illuminated that evening.

From the Launch to the Commissioning

At the time of her launch the *Szent István* was in 66 percent complete. In contrast to her sisters, she was launched with bow and stern armor plates on. After the launch she was towed to Pola where she was examined in the great floating dock of the Navy between 9 and 17 February. Three days after the launch and one day after Pliskovac’s death the

Vienna Social Democrat newspaper “Arbeiter Zeitung” criticized the Danubius shipyard in an article titled “Der Blut-Dreadnought” (The Bloody Dreadnought) stating that many grave accidents had occurred during the construction thanks to the hunger for profit of the owners of the shipyard. The article accused Manfréd Weisz and his (alleged) greed as being the primary cause of the unconscionably high number of accidents. On the basis of the abovementioned article the Navy made an investigation into the yard that resulted in clearing the Danubius of the accusations of the newspaper. It was concluded that the actual number of the accidents was much less than the alleged number published in the article.²⁹⁷ The gravest accident in the Danubius occurred on 26 November 1913 when the 100 ton crane which was under construction collapsed causing the deaths of three workers.²⁹⁸

As mentioned above, because the Navy considered the positioning of the searchlights on the STT built ships less than satisfactory, the searchlight plan of the *Szent István* was modified. This modification added a surplus weight of 54.4 tons to the superstructure high above the waterline.²⁹⁹

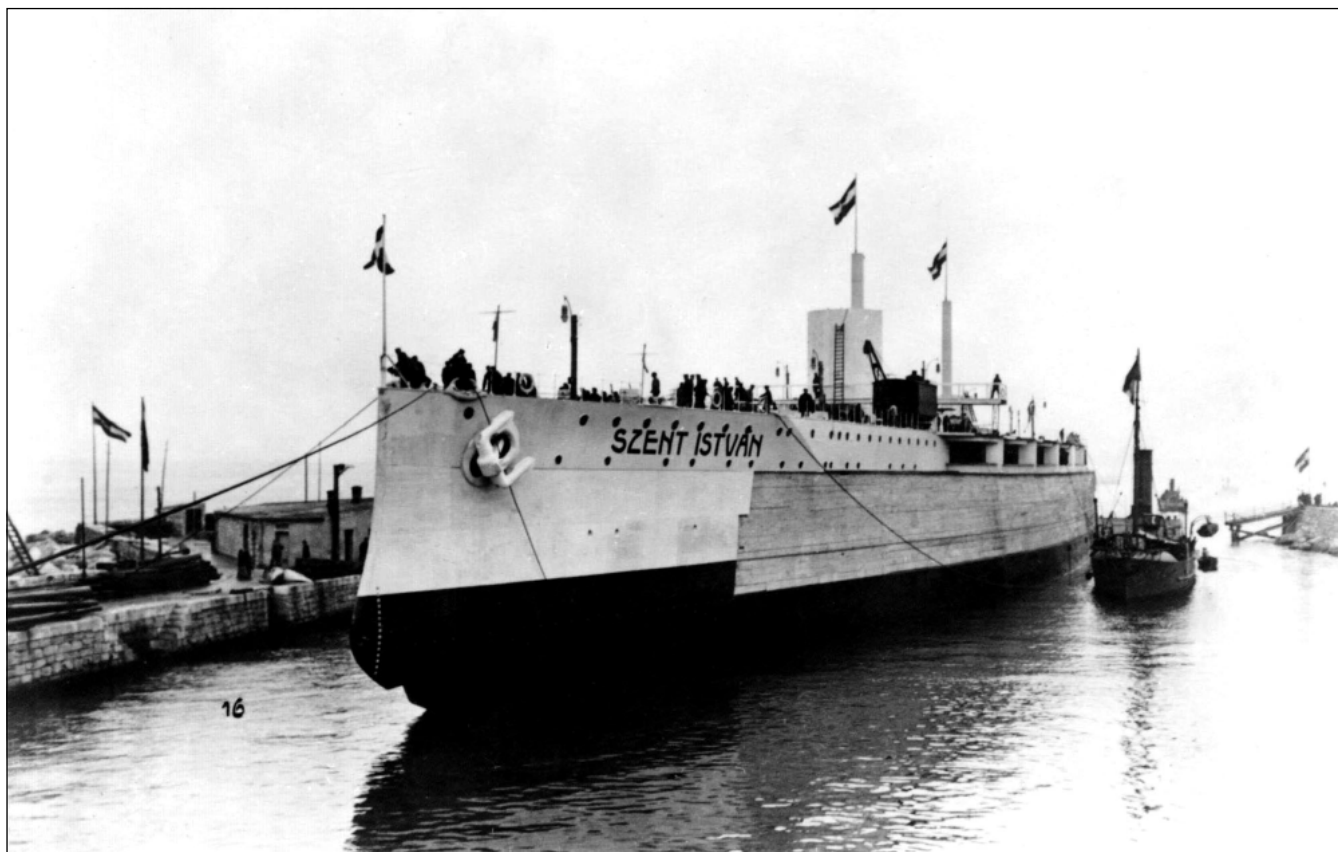

41 *Szent István* after her launch. Note the bow armor plates on and the teak planking as backing for belt armor

The MTK later stated that the surplus weight of the searchlight platform did not adversely affect the stability of the ship.³⁰⁰

The further works on the *Szent István* were also slow. The shipyard itself was fully completed on June 2 1914. On this date, the battleship was in 71.4 percent complete.³⁰¹ It turned out only after the delivery of the components of the gun turrets that the center pivot's bases of the aft turrets were 17 cm deeper than on the other ships due to the different propeller shaft arrangement. The parts of the bottom of the revolving stalks of the aft turrets had to be reshaped in the shipyard.³⁰²

When the war broke out, the Navy ordered on 31 July to tow the ship to the Pola Arsenal in order to better protect the ship and oversee its completion. According to the Navy's plan the building would continue at the Arsenal under the direction of the Danubius and with the yard's own workers. The negotiations between the Navy and the Danubius lasted to January 1915 and the formal agreement was only signed on 25 April 1915. On that day the battleship was in 83 percent complete.³⁰³ The outfitting of the four gun turrets was extremely slow the engineer of the Škoda Works who su-

pervised this works complained that every phase of the works lasted twice as long as in the STT.³⁰⁴

The outbreak of the war led to the cancellation of the installation of torpedo nets on the *Szent István*. The torpedo nets were imported from Britain and as of August 1914 no more shipments were expected. The net booms and the net pieces delivered earlier were stored in the Arsenal as spare parts for the three STT built dreadnoughts. The holes which had been already bored for the steel booms of the net were sealed with bolts.³⁰⁵ After the negative German experiences of the war the nets were removed in 1917 from the other units of the class. The *Szent István* had from the start so called "bomb nets", pieces of old torpedo nets on a metal frame fitted over the funnel caps whose purpose was to protect the boilers from aerial bombs.

The delay of the works became enormous. The workers of the Danubius had no interest in finishing the construction of the *Szent István* because after the completion of the battleship the shipyard would dismiss the majority of them and the Army could then conscript the dismissed workers. The works on the gun turrets were finished in June 1915. In the same month the Arsenal reported that

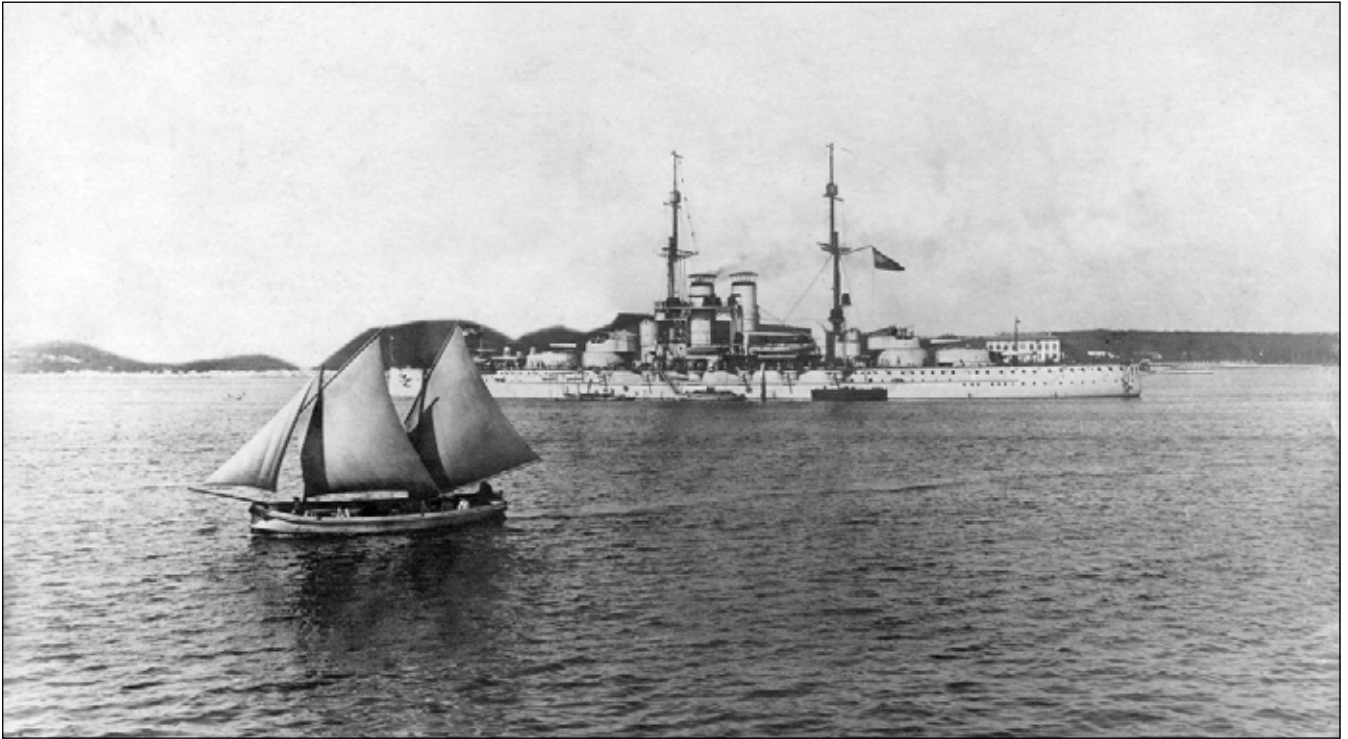

42 Battleship *Szent István*. Note the searchlight platform around the funnels and the bomb-nets over the funnel caps.
In the foreground a trabaccolo, a typical sailing coaster of the Adriatic

it was expected that the ship would be finished at the end of 1915.³⁰⁶ Characteristic for the wartime situation the Navy hurriedly fitted the *Szent István* with the last available soda water maker because due to the material shortage, especially of copper there was no hope to purchase new soda makers.³⁰⁷ Cold soda water especially in the hot Adriatic summers significantly increased the well-being of the seamen.

The first stationary machinery trial of the *Szent István* began on 14 August 1915. The full power trials of the *Szent István* were executed in the Fasana Channel on 20 and 21 November when her machinery produced 26,400 SHP but her speed oddly enough was not mentioned in the official test report. There are allegations that the ship exceeded 21 knots but there is no evidence that this is true. Others state that the ship allegedly did not reach the design speed of 20 knots.³⁰⁸ However, her machinery performed better than her sister's. The STT built ships were not able to maintain their maximum speed (20.3–20.4 knots) more than two hours, while the *Szent István* with her heavier and more capable boilers could run at full speed more than eight hours.³⁰⁹ Because of the wartime conditions some trials (for example the 30 hours trial with 17,000 SHP power) were omitted. Thanks to the fewer trials the Navy saved 888 tons of coal.³¹⁰

While the delivery record was signed on 11 December 1915³¹¹ the Navy officially commissioned the *Szent István* on 17 November 1915 under the command of Linienschiffskapitän Edmund Grassberger. The Magyar Adria Egyesület presented the bronze plaque of *Szent István* and a special ensign (*díszlobogó*) to the ship on 6 January 1916. The Adria Egyesület in June 1916 presented four small stained glasses which were fitted into the four windows of the rear bulkhead of the admiral's salon two-two on either side of the plaque.

During the trials it turned out that at full speed when the ship began to turn with rudder turned to the maximum angle (35 degrees) *Szent István* listed more than double (19.75 degrees measured by gyroscope) than her sisters and water flooded her casemates of the secondary battery because the casemate sealings were not fitted yet. Due to the sudden list many fell on the bridge and on the deck. Grassberger in his report blamed the high searchlight platform for the extreme list, but the engineers of the MTK stated that the different screw arrangement and the different form of the stern of the ship were the principal reasons of this serious fault. The Navy ordered to limit the rudder angle at high speeds to 15 degrees. On the same trial the *Szent István* produced a list of 8 degrees at full speed with rudder turned to 15 degrees.³¹²

The gunnery trials were conducted on 18 and 19 November and took place in the Fasana Channel. The trial of the main battery was conducted at a speed of 14-16 knots. The first salvo was fired at a range of 15,200 m then the range was gradually decreased to 10,000 m. The full salvos with the guns in each turret coupled together put extreme stress on the gun turrets and hull structure and resulted in the decalibration of the turret rangefinders. At a speed of 16 knots the fire control system failed to follow the rapidly changing range rate. There was a special problem in turret No III as the temperature rose to 45 degrees C because the ventilation duct was near a heat source.³¹³ The cost of repairing the damages caused by the 30.5 cm guns was 1,460 Kronen. On her sisters the costs of the repairs after the gunnery trials were similar.³¹⁴ The final trial of the gun turrets was conducted on 15 January 1916.³¹⁵

When the *Szent István* was docked after the trials there were found much greater distortions in the underwater hull structure than on her sisters. A committee established that the Danubius had made some structural parts from lower quality material than the prescribed in the contract.³¹⁶ The delivery record of 11 December listed the following issues: there were problems with some ventilators and with the refrigeration plants of the ammunition magazines, some spare parts were missing and the caulking of the teak deck was defective.³¹⁷ On a summer maneuver in 1916 the whole electric system of the ship broke down, its manufacturer, the Ganz Villamossági Rt. repaired it under guarantee.³¹⁸ The aft capstan also had to be replaced because when it was fitted sand and gravel got into its mechanism due to the negligence of shipyard workers.³¹⁹

The total sum which the Navy paid to the Danubius for the hull and the machinery was 22,589,800 Kronen. In 1916, the Navy claimed a penalty of 475,000 Kronen from the Danubius for the delay. The Danubius asked the deduction of 398,466 Kronen as a compensation for the additional charges of the works in the Arsenal.³²⁰ The Navy counting the strikes and wartime circumstances finally reduced the penalty to 312,500 Kronen.³²¹ Then the Danubius asked to cancel the penalty but the Navy refused it. Finally, the Navy and the shipyard agreed to postpone the negotiations on the penalty until the end of the war.³²²

Szent István was an unlucky ship: on her very first mission, during "Operation Korfu" on 10 June 1918, she was torpedoed and sunk by an Italian motor torpedo boat (MAS). In the "little war" on the Adriatic the heavy units of both the Austro-Hungarian and the Italian navies rested in their bases at Pola and respectively at Taranto. On 8 and 9 June Flottenkommandant Kontreadmiral Miklós Horthy sail to sea with all four dreadnoughts in two separate groups in an attempt to attack the Otranto Barrage and smash the inferior Allied forces. The second group was led by the *Szent István* followed by the *Tegetthoff* left Pola on the evening of 9 June. On 10 June, at 3:20 a.m. they accidentally met two Italian motor torpedo boats led by the famous Italian MAS commander capitano di corvetta Luigi Rizzo. The MAS-21 attacked the *Tegetthoff* without success. MAS-15 however succeeded in hitting the *Szent István* with two torpedoes. The torpedo protection system designed by Siegfried Popper failed to protect the ship. After three hours at 6:07 a.m. she capsized and at 6:12 a.m. sank with 89 hands.

Opinions on the *Szent István*

On 8 April 1916, the Navy asked the commanders of the battleships of the *Tegetthoff* class to write a report on their ships. While the other commanders wrote useful reports, Grassberger's first version was rather a pamphlet against the shipyard so the Navy rejected it. Grassberger was notorious in the Navy for his manner and from his reports it is clearly visible that he disliked his new ship. Grassberger was the commander of the fleet's flagship *Viribus Unitis* before his appointment to the *Szent István* and may he have felt this change of command as a reduction in prestige. His second version of the report was accepted but some of his proposals received criticism.

Grassberger had previously criticized his new ship in his 3 December 1915 report on the list observed at large rudder angles during the full force trial. After presenting his theory on the causes of the list, he criticized the ammunition hoists of the 15 cm guns and questioned the watertightness of the manholes. Then he wrote a lengthy pamphlet on the (by his opinion) wrong construction of the waste pipes, backed with quotes from German and

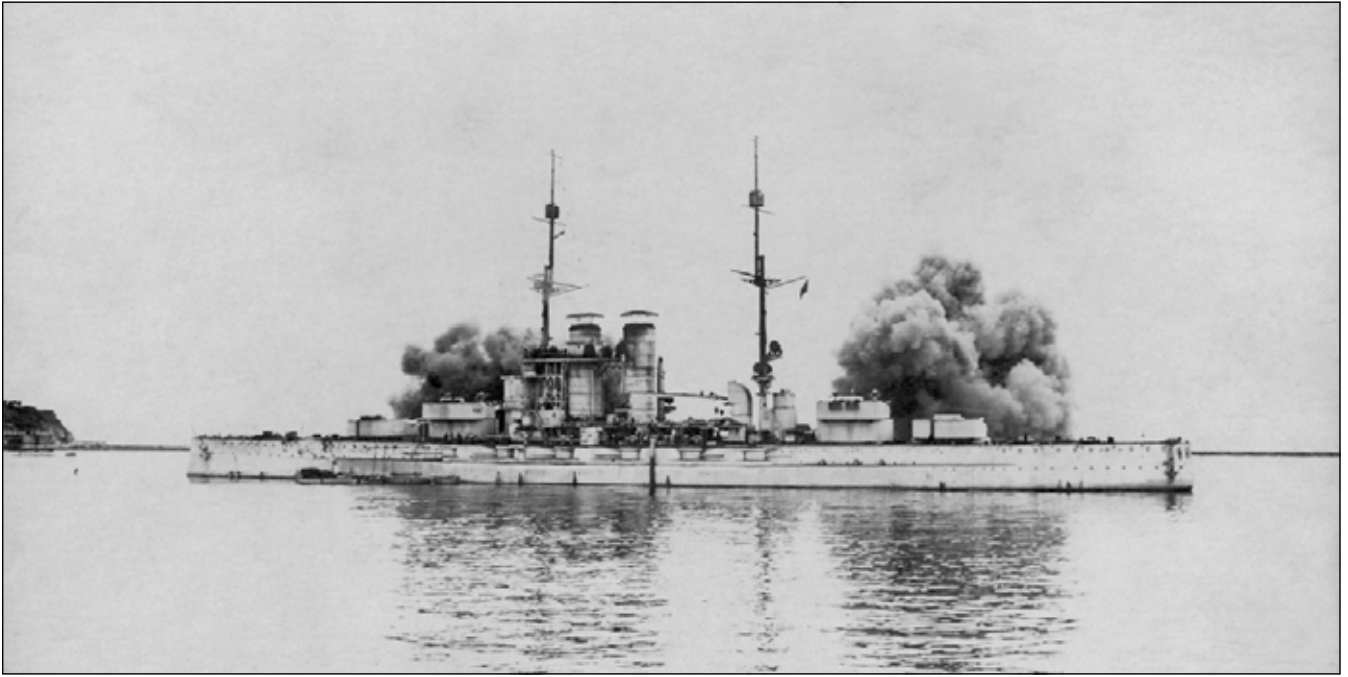

43 Szent István fires her main battery during a gunnery practice

British shipbuilding establishments and blamed the Danubius. He lamented that these waste pipes lacked flap valves and when the ship listed heavily during her trials, water flooded into the seamen's toilets.³²³ In its answer of 18 January 1916 the Arsenal politely told Grassberger to go to hell and refuted his statements. They informed him that the lack of the flap valves was not the fault of the shipyard but was done per the Navy's order. The Navy had found that these flap valves were prone to sticking due to rust, rendering it impossible to flush the toilet. They added that new technologies had to be based upon practical experience and not exclusively on theoretical textbooks.³²⁴

The second version of Grassberger's report on his ship was written in September or October 1916. He started his report with the bow. In his opinion, the bow was too heavy and low and it had a bad and antiquated shape. At full load the draught at the bow was 20 cm greater than at the stern. Beside this line there is a handwritten note in the report "Maybe the ship was not correctly trimmed?" During the gunnery trial at 16 knots the foredeck was almost constantly wet and the spray reached the upper gun turret. For the future battleships he proposed a bow similar to the Japanese battleships combined with a raised forecastle deck.³²⁵

In his opinion the ships of this class were overloaded with the upper triple turrets, and recom-

mended that the use of twin turrets as superimposed turrets would lessen the stability problems. He also blamed the construction of the fore conning tower for the high center of gravity of the ship. He eventually repeated the statements of the commander of the *Viribus Unitis* on the conning tower adding that an unlucky hit on the lower part could cause the fall of the heavy upper part of the conning tower. He wrote that at a speed of 14 knots or more the conning tower had been vibrating during the gunnery trial so that it had hindered the fire control. For this phenomenon he blamed the weak understructure of the fore conning tower.³²⁶ The searchlight platform over the bridge which was a unique feature of the *Szent István* hindered searching the air for enemy aircrafts. He proposed to create weatherproof anti-submarine lookout posts. He criticized the small and cramped bridge and the arrangement of the navigational equipment.³²⁷

The chapter on the armament of Grassberger's report started with the mention of the dangerous unprotected slot between the barbette and the gunhouse. While he did not make such serious claims about the turret ventilation as the commander of the *Viribus Unitis*, he proposed relocating the air inlets and the ventilators of the turret ventilation. For the future battleships he proposed diesel generators placed near the trunks of the gun turrets instead of remote, steam turbine driven generators.³²⁸

The commander of the *Szent István* in his report dealt with the secondary battery most elaborately. He wrote that the ventilation of the 15 cm casemates was insufficient when the hatches were closed on the Oberdeck. He complained that the casemates were not fitted with a dedicated ventilation system and fresh air could only be supplied through the gunports, but often only smoke and propellant gases were sucked into the casemates through these ports. The other commanders did not mention this ventilation problem. Linienschiffskapitän Teuschl, the commander of the *Viribus Unitis* wrote in his report that usually some hatches were open when the 15 cm guns were firing because the spent cartridges were transported through these hatches to the Oberdeck. Grassberger considered the communication of the fire data and the use of the gunsights of the 15 cm guns difficult, Teuschl had similar views.³²⁹

Grassberger criticized the armor scheme of the ship which he considered outdated and vulnerable to plunging fire and aerial bombs. He condemned the lack of armored gratings in the funnels and ventilation ducts. He considered the ventilation in general insufficient and proposed a totally new concept of ventilation for the future battleships. He complained about the ventilation and cable ducts which horizontally passed through main watertight bulkheads. In fact, this practice was accepted by the MTK and the Arsenal and the bulkheads of

the Trieste built units were similarly constructed. He wrote that on the *Tegetthoffs* too many watertight doors were cut in the watertight bulkheads which threatened their watertightness. On the *Szent István*, he added, even more doors were cut, because the transverse bulkhead which separated the fore and the aft turbine rooms were pierced by two doors which could not be closed remotely. Grassberger did not mention that the three STT built dreadnoughts had not been fitted with similar transverse watertight bulkheads in their turbine rooms. On the boilers of the *Szent István* he wrote that in contrast to the STT made boilers they could provide enough steam for the turbines. After his remarks on the boilers Grassberger wrote a lengthy explication of his views on the training of stokers.³³⁰

Grassberger's report was similar in many parts to the other commander's reports because they all criticized the common flaws of the *Tegetthoff* class: the weak construction of the hull and the watertight bulkheads, the insufficient ventilation, the low freeboard, the bad and outdated shape of the bow which rendered the ships very wet even in calm weather and the uncomfortable and crowded crew compartments. He as the other commanders considered the bow and the stern submerged torpedo tubes entirely superfluous. Grassberger's report differed from his colleagues' chiefly in its style, which was characterized by pedantry so typical of him.³³¹

Technical data of the *Tegetthoff* class

Length on waterline: 151 m

Overall length: 152.18 m

Beam: 27.99 m

Draught: 8.59 m

Displacements

Normal or trial: 20,013 metric tons (20,008 metric tons)

Full load: 21,595 metric tons (21,689 metric tons)

Weights (*Viribus Unitis*, calculation from August 1912³³²)

Hull: 5,313 tons (25.8 %)

Equipment and provisions: 1,488 (7.2 %)

Armament including gun turrets: 3,327 tons (16.2 %)

Ammunition: 902 tons (4.4 %)

Machinery: 1,486 tons (7.3 %)

Electric power plant and equipment: 349 tons (1.7 %)

Vertical armor: 5,103 tons (24.8 %)

Deck and torpedo protection: 1,686 tons (8.2 %)

Fuel: 900 tons (4.4 %)

Total: 20,554 metric tons

Machinery

Twelve coal firing Yarrow water tube boilers with oil spraying

(Twelve coal firing Babcock-Wilcox water tube boilers with oil spraying and superheaters)

Boilers in two boiler rooms, two funnels

Two sets of Parsons-turbines on four shafts

(Two sets of AEG-Curtiss turbines on two shafts)
 Four screws of 2750 mm diameter (two screws of 4000 mm diameter)
 Turbines divided in two watertight spaces, separated by a centerline longitudinal bulkhead
 (Turbines divided in four watertight spaces, separated by a centerline longitudinal bulkhead and a transversal bulkhead)
 Designed power: 25,000 SHP
Viribus Unitis: 27,383 SHP
Tegetthoff: 25,638 SHP
Prinz Eugen: 27,183 SHP
Szent István: 26,400 SHP
 Designed speed: 20 knots
Viribus Unitis: 20.49 knots
Tegetthoff: 20.31 knots
Prinz Eugen: 20.41 knots
Szent István: N/A
 Range: 5,000 nautical miles
 Fuel: coal 1,871 tons or briquette 1,536 tons, oil 162 tons
 (Coal 1,845 tons or briquette 1,519 tons, oil 267 tons)

Electric power

4×300 KW turbine-driven DC dynamos
 2×150 KW turbine-driven DC dynamos
 2×150 KW motor-driven DC dynamos
 2×AC generators

Armor

(KC: Krupp cemented, K: Krupp non-cemented, SP: Spezialstahl, SM: Siemens-Martin)
 Belt: 280 mm KC, lower part tapered to 180 mm KC on 80 mm teak
 Upper belt: 180 mm KC
 Casemate: 180 mm KC
 Bow/stern: 150/150 mm KC
 Fore and aft armored bulkheads: 150 mm KC
 Torpedo bulkhead: 25+25 mm SP
 Conning tower front and sides/back/roof: 280/150 mm KC/60 mm SM
 Aft conning tower
 15 cm control towers front and sides/roof: 180 mm KC/40 mm SM
 Barbettes: 280 mm KC
 Armored deck sloped parts/horizontal part: 18 mm and 18+30 mm/18+18 mm SM
 Gun turrets face and sides/inclined parts/roof: 280 mm/200-130 mm KC/60 mm K

Armament

12×30.5 cm/45 K10 Škoda guns with sliding wedge breech (Krupp-system)
 Weight of the gun turrets lower/superimposed 680/690 tons
 Weight of barrel with breech: 54.25 tons
 Elevation: -4°/+20°
 Elevation/train rate: 3° per sec/3° per sec
 Allowance for each gun: 76
 Projectile's weight: 450 kg
 Muzzle velocity: 800 mps
 Rate of fire: 1-2 rounds per minute
 Range: 22,000 m later 19,000 m

12×15 cm/50 Škoda guns with sliding wedge breech in casemates
 Weight of a gun with shield: 19.8 tons
 Weight of the barrel: 6,085 kg
 Elevation: -6°/+15°
 Weight of the ammunition: 80 kg
 Allowance for each gun: 180
 Projectile's weight: 45.5 kg
 Muzzle velocity: 880 mps
 Rate of fire: 6 rounds per minute
 Range: 15,000 m

18×7 cm/50 (6.6 cm) Škoda guns with sliding wedge breech on central pivots
 Weight of a gun with mounting: 2300 kg
 Elevation: -6.5°/+20°
 Weight of the ammunition: 8.5 kg
 Allowance for each gun: 400
 Projectile's weight: 4.5 kg
 Muzzle velocity: 850 mps
 Rate of fire: 20 rounds per minute

4×7 cm/50 (3×7 cm) (6.6 cm) Škoda AA guns with sliding wedge breech on central pivots
 Weight of a gun with mounting: 2,030 kg
 Elevation: -5°/+90°
 Weight of the ammunition: 8.5 kg
 Allowance for each gun: 200
 Projectile's weight: 4.5 kg
 Muzzle velocity: 830 mps
 Rate of fire: 20 rounds per minute

4×53.3 cm Whitehead submerged torpedo tubes (1 bow, 1 stern, 1-1 broadsides)
 Allowance: 3-3 for fore & aft tubes, 4-4 for broadside tubes

Torpedo's weight: 1,336 kg
Overall length: 6.3 m
Explosive charge: 180 kg

Fire control

2×3,658 mm (12 feet) Barr&Strouds rangefinders
on the conning towers
4×2,743 mm (9 feet) Barr&Strouds rangefinders
in the gun turrets
2×2,743 mm (9 feet) Barr&Strouds rangefinders
in the 15 cm fire control towers
11×110 cm searchlights

Boats

Two 13 ton electric boat cranes
1×13 ton steam barge
1×9 ton and 1×5 ton motor barges
2×4.7 ton sailing barges
4× cutters
1× rescue cutter
2× jolly boats
2× motor-gigs
4× small jolly boats

Complement

38 officers, 1,056 men

Call signs

Viribus Unitis: AU and 60,033
Tegetthoff: AF and 60,034
Prinz Eugen: AP and 60,035
Szent István: AJ and 60,036

Commanders

(Lschk: Linienschiffskapitän)

Viribus Unitis

Lschk Anton Willenik 27 August 1912
Lschk Anton Alexander Hansa 25 April 1913
Lschk Edmund Grassberger 17 August 1914
Lschk Kamillo Teuschl 15 August 1915
Lschk Gustav Ritter von Nauta 5 November 1917
Lschk Janko Vuković de Podkapelski March 1918

Tegetthoff

Lschk Anton Alexander Hansa 27 March 1913
Lschk Franz von Holub 10 June 1913
Lschk Heinrich Ritter von Nauta
20 February 1917
Lschk Heinrich Freiherr Pergler von Perglas
15 April 1918

Prinz Eugen

Lschk Johann Graf von und zu Firmian
9 April 1914
Lschk Dragutin von Prica 15 May 1917
Lschk Miklós Horthy, nagybányai 24 November
1917 – 26 February 1918
N/A

Szent István

Lschk Edmund Grassberger 28 October 1915
Lschk Franz von Teichgräber 4 March 1917 –
29 September 1917
Lschk Franz Lauffer 10 October 1917
Lschk Heinrich Seitz von Treffen
11 March 1918 – 10 June 1918

S.M.S. SZENT ISTVÁN 1918

The Hungarian Battleship
Scale 1:200

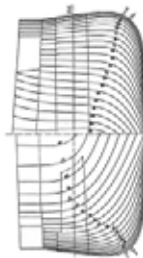
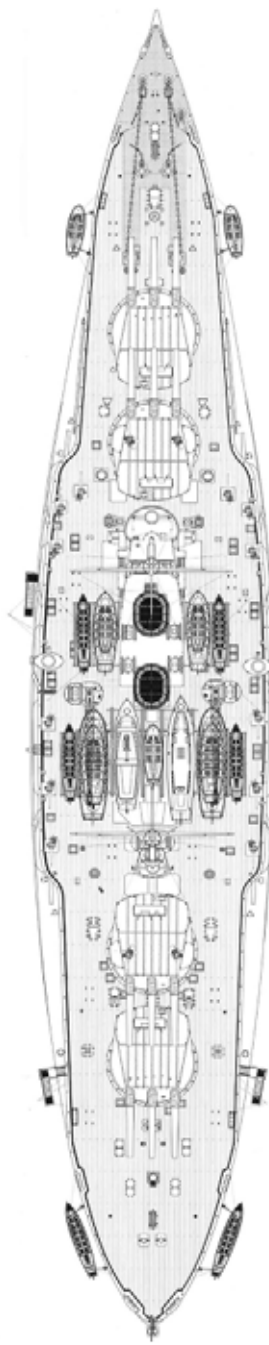
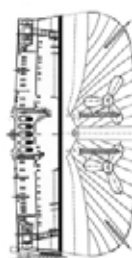
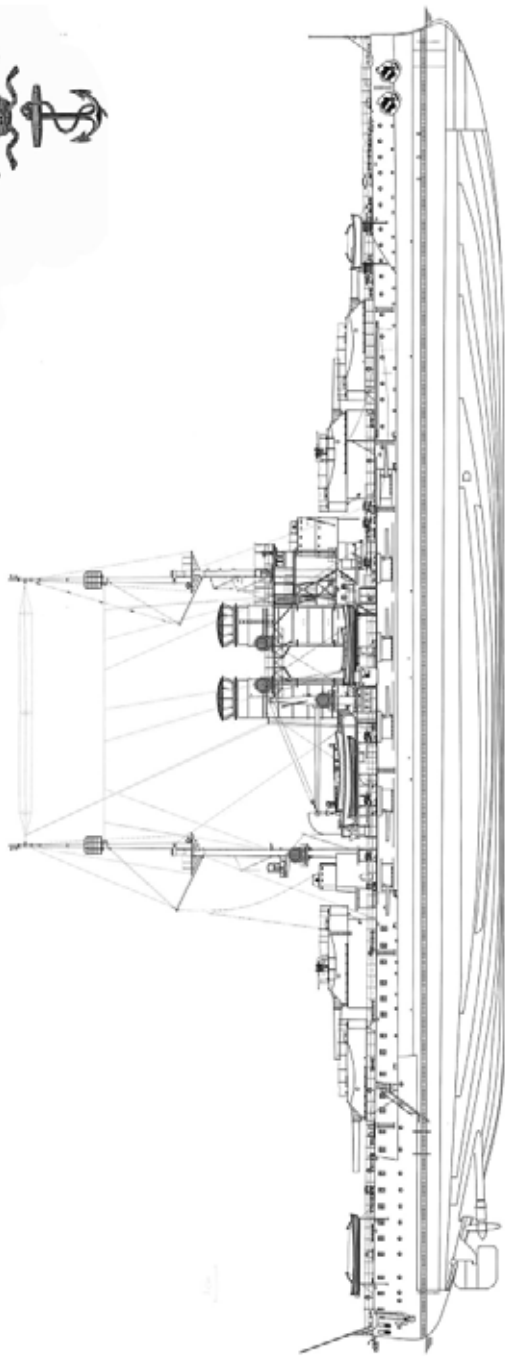
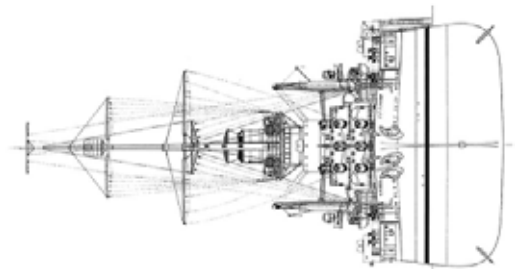

d. H. d. „Viribus Unitis.“

Maßstab 1:1000.

Statthausdeck.

ARCHIV DER K. U. K. S. B. D.

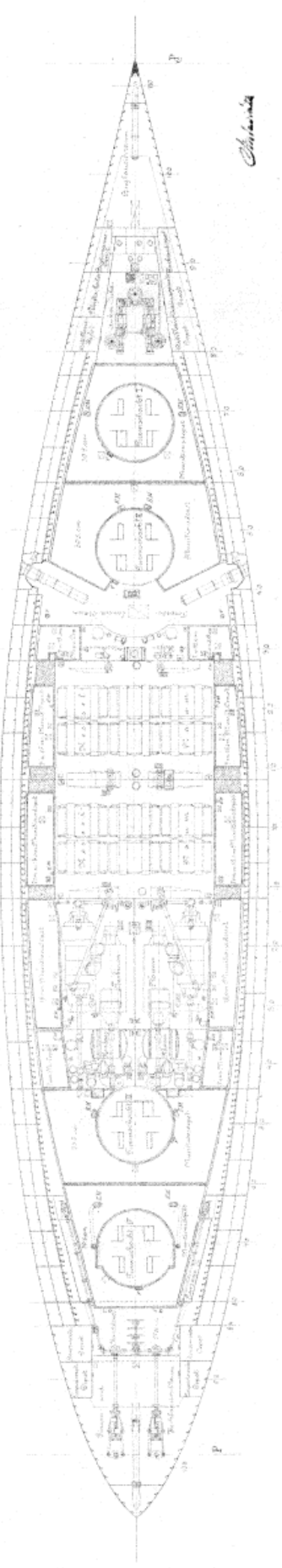

BM Einheitsmaß der Mittelgeschütze
 P ...
 ...

Chimney

1/1000

d. H. d. „Viribus Unitis.“

Maßstab 1:1000.

Zwischendeck.

ARCHIV DER K. U. K. S. B. D.

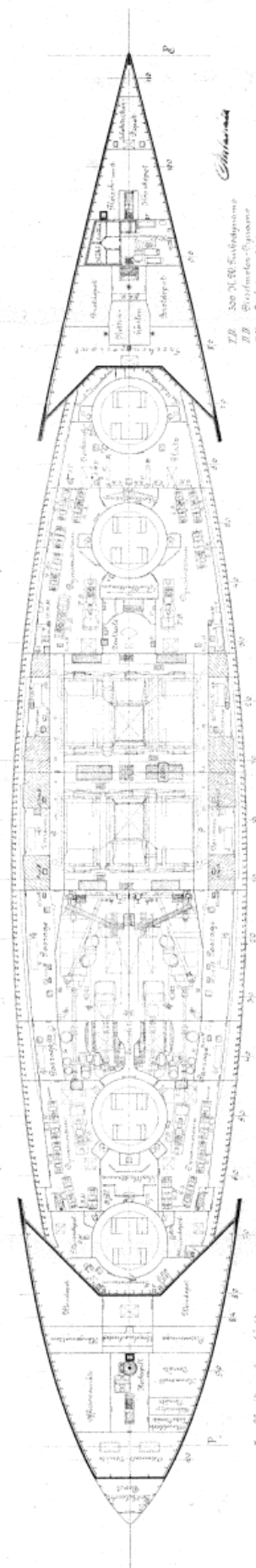

X ...
 P ...
 ...

ZZ ...
 ...
 ...

Chimney

1/1000

S.M.S. „Viribus Unitis“

Maßstab 1:500.

ARCHIV DER K. U. K. S. B. D.

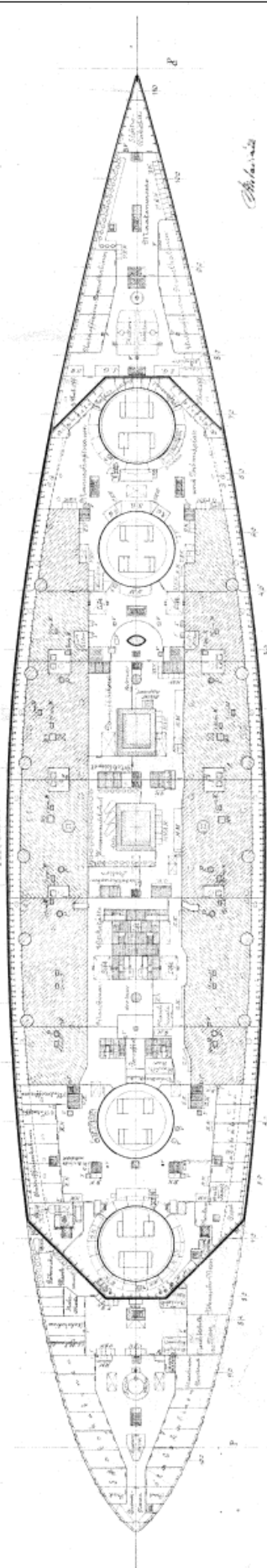

M... Hauptmasteinstiegstürme
 M... Mastenstützen
 P... Mastenstützen
 R... Mastenstützen

B... Bockschiffe
 B... Bockschiffe
 B... Bockschiffe

B... Bockschiffe
 B... Bockschiffe
 B... Bockschiffe

Z. 111

S.M.S. „Viribus Unitis“

Maßstab 1:500.

ARCHIV DER K. U. K. S. B. D.

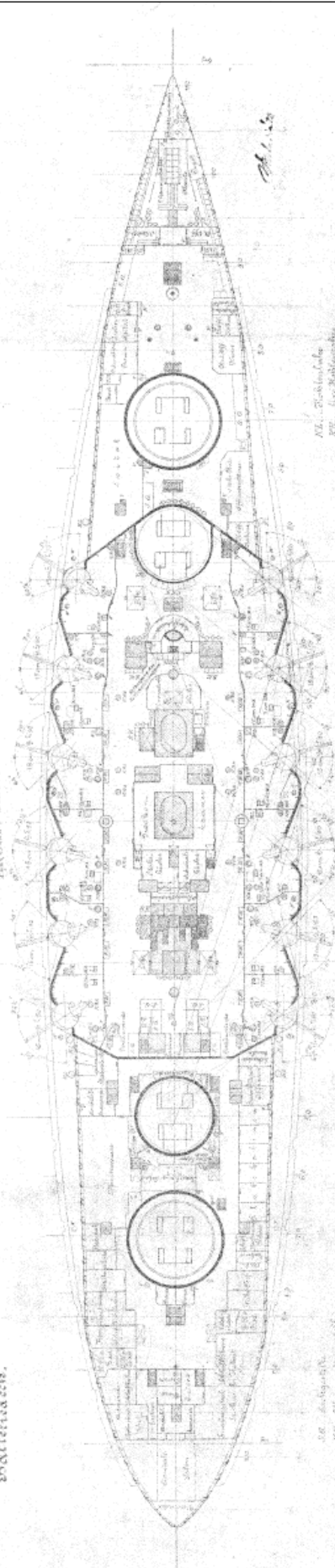

M... Hauptmasteinstiegstürme
 M... Mastenstützen
 P... Mastenstützen
 R... Mastenstützen

B... Bockschiffe
 B... Bockschiffe
 B... Bockschiffe

B... Bockschiffe
 B... Bockschiffe
 B... Bockschiffe

Z. 111

d. M. d. „Viribus Unitis“

Maßstab 1:1000.

Die elektrischen Anlagen sind
den 26. Blattplanen beizufügen.

Die elektrischen Anlagen
sind den 26. Blattplanen
beizufügen.

ANCHY DER K. K. S. B. D.

Manöverdeck.

Chimäre

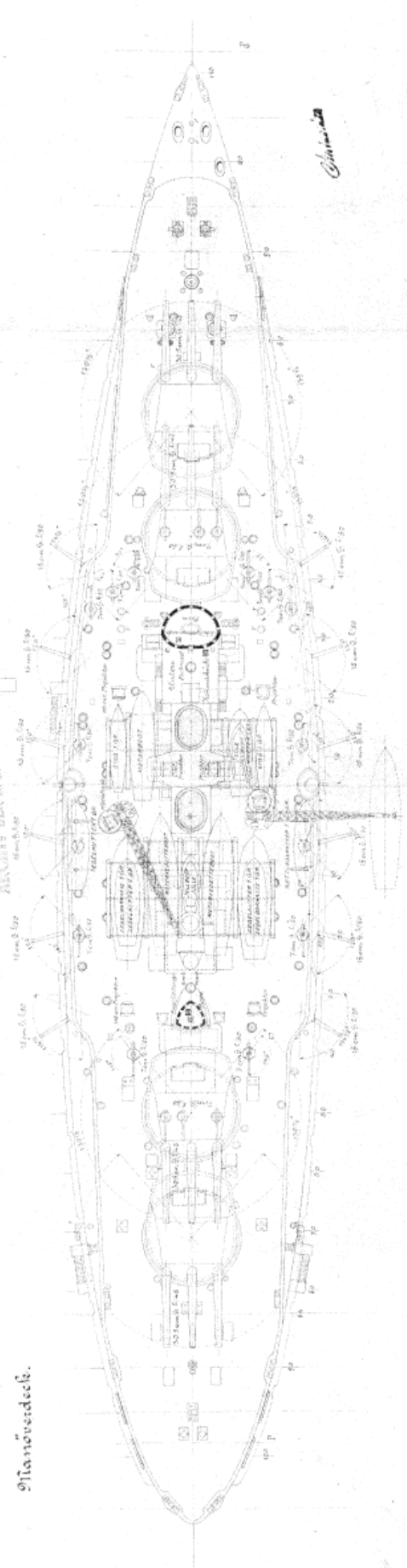

d. M. d. „Viribus Unitis“

Maßstab 1:1000.

Section 24 P. 1000

Section 117

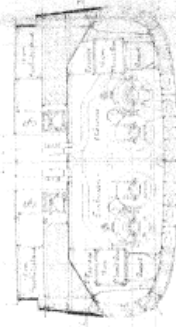

Section 217 1:1000

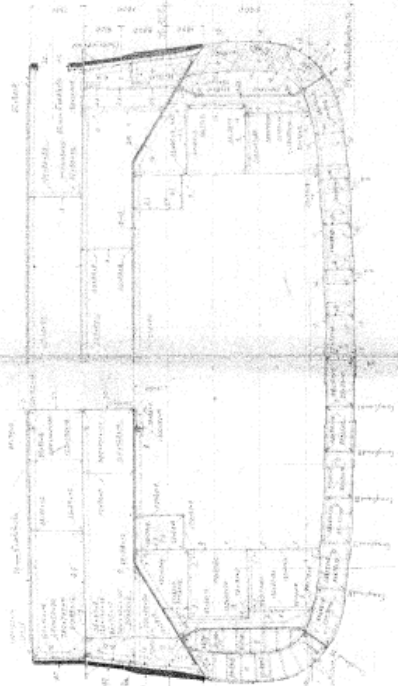
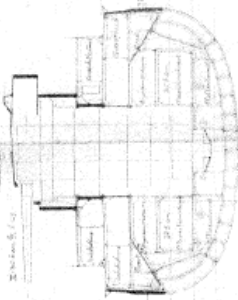

Section 68 J 1:1000

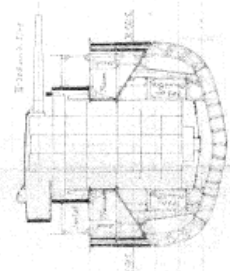

Section 99 E 1:1000

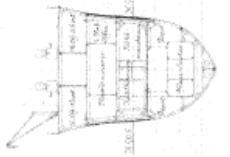

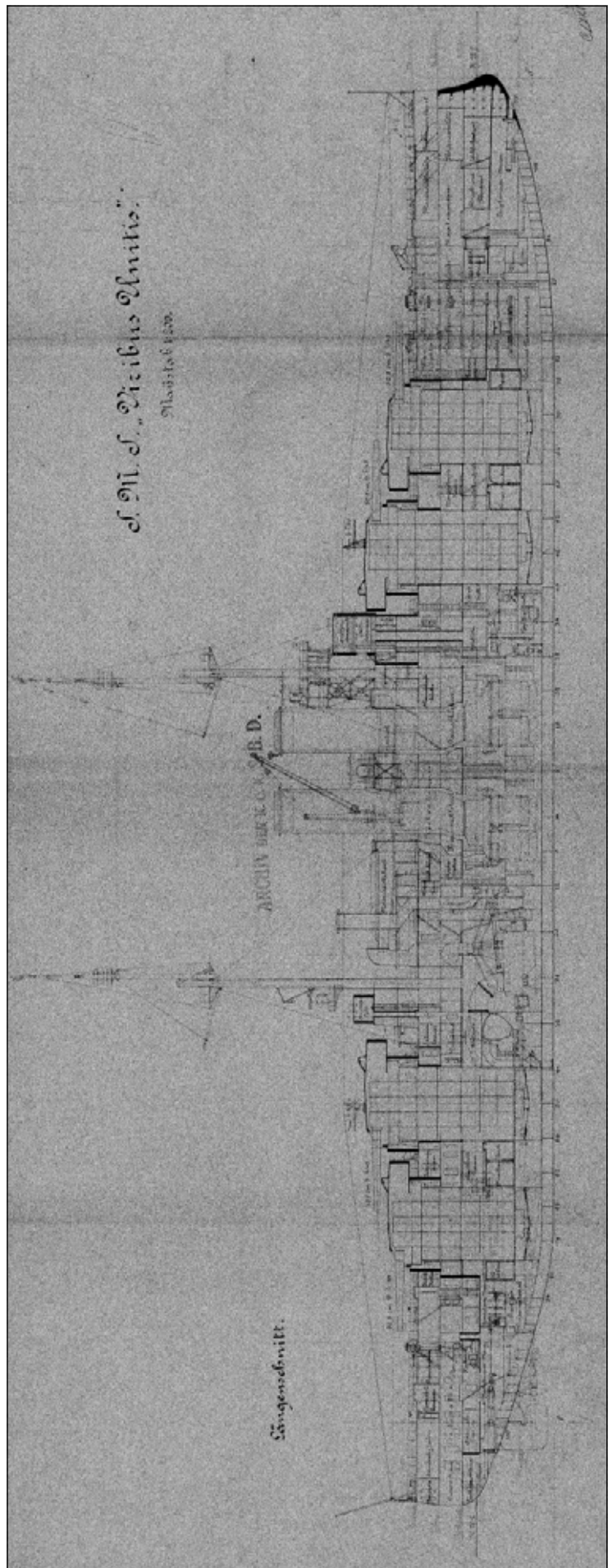

“THE MONARCH CLASS MUST BE REPLACED!” THE “IMPROVED TEGETTHOFF” CLASS

In February and March 1911, the Hungarian and Austrian delegations voted the extraordinary credit of 312 million Kronen allowing the construction of the dreadnoughts of the *Tegetthoff* class. In the summer of the same year started the story of the second dreadnought class to be built starting in 1914. This story ended in February 1915 with the cancellation of the program due to the restrictions caused by the Great War. Two of the four battleships were scheduled to be built in the Ganz and Co Danubius shipyard in Fiume and that would have been the greatest order in the history of the Hungarian shipyard.

The best known and most popular name of this planned but never built class “Ersatz Monarch” originated from the leading article of August 1913 issue of “Die Flagge”, the monthly magazine of Österreichische Flottenverein: “The Monarch class must be replaced!” In the official files the Navy never called this class “Ersatz Monarch” (in fact this type of designation was in use in the Imperial German Navy), the designs were labeled simply as “23,400 ton battleship” or “24,500 ton battleship”, and later as “Enlarged Tegetthoff class” (vergrößerten Typ Tegetthoff) or “Improved Tegetthoff class” (verstärkten Typ Tegetthoff).

On 3 June 1911, three weeks before the launch of the first Austro-Hungarian dreadnought, *Viribus Unitis*, the Navy started the design work on the second dreadnought class. According to the international trends, the future ships had to be larger, better protected and armed with larger caliber main battery.³³³ The Škoda Works in April 1911 submitted to the Navy plans for 34.5 cm twin and triple turrets with any-elevation loading system.³³⁴

In the worldwide climate of navalism, the Austro-Hungarian Navy stated primary reasons to explain its need for a new class of dreadnoughts: first, the Navy had to counterbalance its eternal rival, Italy’s plan for new battleships; second, with the Italian-Austro-Hungarian Naval Convention of 1913, the fleet of Austria-Hungary became a Mediterranean factor instead of a mere coastal defense force; and third, that it was impossible without dread-

nought-type battleships to maintain the status of great power. Furthermore, the permanent Balkan-crisis of 1912-1913, the battleships of the Imperial and Royal Navy (*Radetzky* class, *Tegetthoff* class) also proved to be very effective tools of power projection.³³⁵

The Navy wanted to start the construction of the new battleships as soon as possible (i.e. in 1913), but the political and financial situation of the Dual Monarchy rendered it impossible until the second half of 1914. Due to the outbreak of the World War I, their construction was cancelled before any of these ships were laid down.

The Design Process

The Austro-Hungarian Navy drew up the first specifications for the future battleship on 3 June 1911 at a board meeting presided over by Obere Schiffbauingenieur Franz Pitzinger.³³⁶ The Marinetechnische Komitee presented two design series under the designation “vergrößerten Typ IV”: a 22,000 ton ship (155×28 m) armed with twelve 30.5 cm guns and a 23,400 ton ship (159.3×28.8 m) armed with ten 34.5 cm guns. It was proposed to study the possibility of using Diesel engines rather than steam turbines.³³⁷ One of the interesting features of these designs was the proposed use of twin casemates for the secondary (15 cm) battery. Unfortunately, due to technical problems, the twin casemates were rejected in early 1912.

In February-March 1912, the Navy made a series of displacement calculations on different variants with different armament and belt armor. Beside the 34.5 cm caliber, the Navy was also studying the possibility of introducing 35.5 cm caliber gun,³³⁸ and ordered the Škoda to produce designs for 35.5 cm gun turrets. On the basis of these calculations, on 11 March 1912 the Navy drew up new specifications for the battleships. There were two variants, the first was a ship of fixed displacement of 23,400 ton and armed with eight 34.5 cm or 35.5 cm guns, and the second was a ship of un-

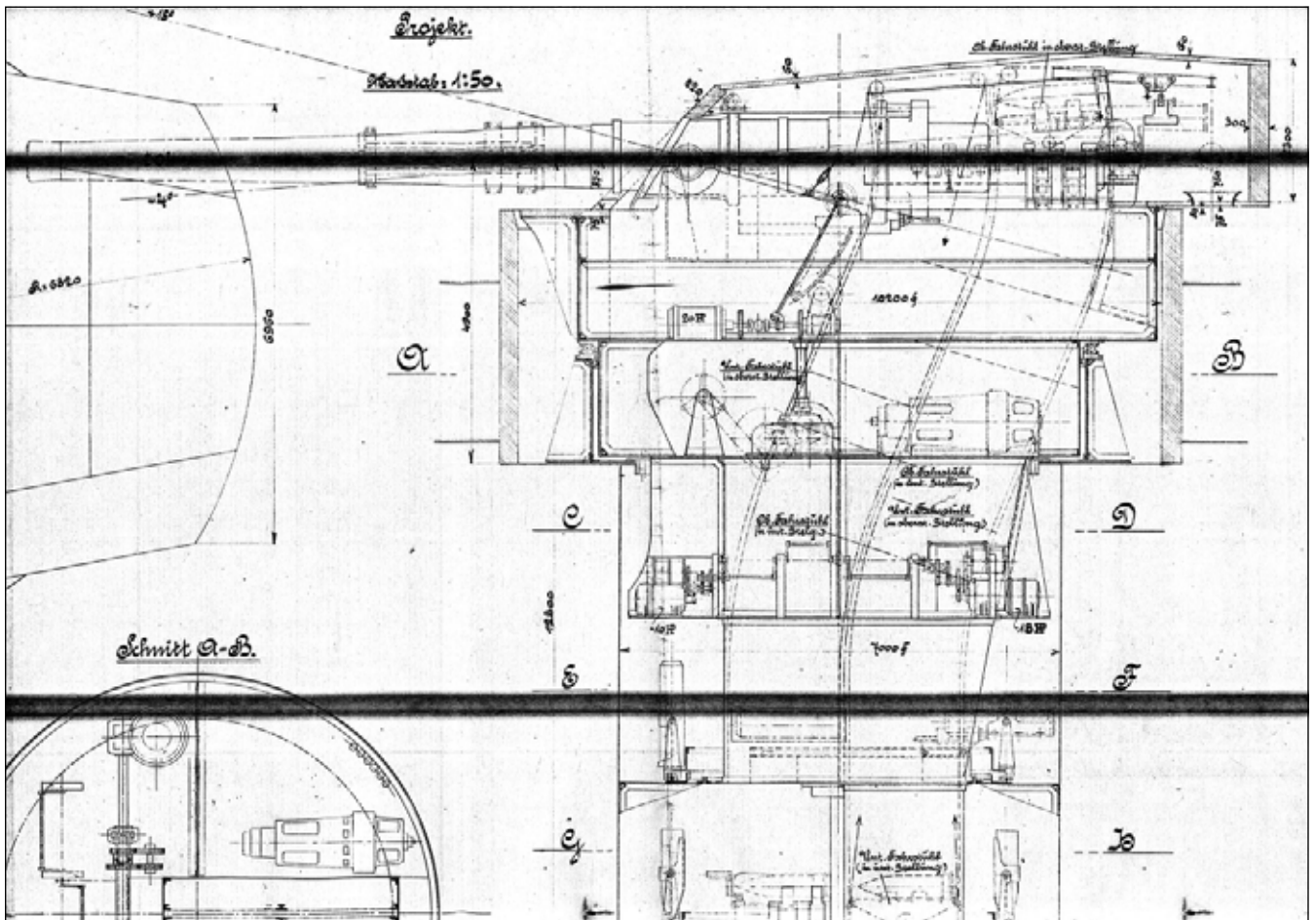

45 Škoda 34.5 cm/45 triple turret design with any-angle loading from 1911

specified displacement and armed with an unspecified number of 35.5 cm guns. Both of these designs had a raised forecastle-deck to improve seagoing performance and to save weight. Two-fifths of the boilers would be oil-fired. The secondary armament of both variants would be composed of eighteen 15 cm and at least eighteen 8.8 cm guns. The Navy prescribed the fitting of antiroll tanks onto the battleships. In 1913, when the Navy learned that the Germans found these tanks to be useless, requirement for fitting of antiroll tanks was dropped. The Navy requested three shipyards, the Stabilimento Tecnico Triestino (STT), the Ganz and Co Danubius and the Cantiere Navale Triestino of Monfalcone (CNT) as well as the MTK to make two series of preliminary designs on the basis of these specifications.³³⁹

On 1 April 1912, the Škoda sent the drawings of the 34.5 cm twin and triple gun turrets to the three shipyards and the MTK, but the 35.5 cm drawings were not finished in time. These Škoda 34.5 cm gun turret designs were with any-angle loading.³⁴⁰ The MTK, the above mentioned shipyards and Schiff-

bauingenieur Silvius Morin presented their designs to the Navy in May-June 1912. Altogether there were 25 variants and subvariants. Unfortunately, the designs of the STT (five variants) and of Morin are completely missing from the files of the Präsidialkanzlei in the Kriegsarchiv of Vienna. Because the 35.5 cm drawings were not in hand, most of the competitors made their designs with 34.5 cm armament. The Ganz and Co Danubius presented only a 23,400 ton design citing the lack of the 35.5 cm turret drawings. The MTK presented a 23,400 ton design (3 subvariants) and a 25,200 ton design (12 subvariants), and the CNT presented a 23,400 ton, a 25,800 ton and a 27,000 ton design, the last two without any technical detail.³⁴¹

The Danubius design had the second best torpedo protection system after the MTK 25,200 design. The distance between the side shell plating and the torpedo bulkhead in the MTK design³⁴³ was 4.1 m and in the Danubius's 3.6 m, but the torpedo bulkhead of the Danubius was thicker (50 mm instead of 38 mm). In the other designs these distances were only 2.9 or even 1.7 m. The

Technical Data of the MTK, Danubius and CNT Designs

	<i>MTK</i> 23,400 ton	<i>MTK</i> 25,200 ton	<i>Danubius</i> 23,400 ton	<i>CNT</i> 23,400 ton
Dimensions in m	171×28	175×28.5	161×29.2	164×28
Power in SHP	30,000	31,000 ³⁴²	30,000	30,000
Speed in knots	21.3	21.2	21	21
Armor in mm	300 belt 38 deck	340 belt 38 deck	300 belt 36-48-63 deck	300 belt
Armament	4×2 34.5 cm	10-13×34.5 cm	4×2 34.5 cm	4×2 34.5 cm

STT simply copied the torpedo protection system of the *Tegetthoff* class. The depth of Morin's system was 2.4 m. The CNT made two variants the first's depth was 2.9 m, the second's only 1.7 m.³⁴⁴

The majority of the MTK's 25,200 ton designs had four turrets, but there were a few variants which had five turrets. The weight of a twin 34.5 cm turret was 618 tons while a triple turret weighed 885 tons. The armor of both turrets was 300-60 mm.³⁴⁵ Turret arrangement of the variant armed with thirteen 34.5 guns was similar to that of the Italian *Andrea Doria*. The MTK's favorite was the design which had four triple turrets.³⁴⁶

On 25 June 1912, a board headed by Vizeadmiral Karl Kailer von Kaltenfels examined the designs, and Franz Pitzinger (who also signed the MTK designs) made brief and negative technical comments on all designs except on his own. Because the naval budget of 1913 made it impossible to start the construction of the new battleships, the board considered the 23,400 ton battleship too small. They envisaged a ship armed with ten heavy guns instead of eight displacing about 24,500 tons. This was the maximum displacement which could fit into the largest existing floating dock of the Navy, Dock No 22, without causing any stability problems.³⁴⁷ On the basis of the board's decision the Navy on 7 July 1912 drew up newer and final specifications for the battleships. The particulars of the new specification were the following: 24,500 ton displacement, ten 35 cm guns in twin and triple turrets and eighteen 15 cm guns, 300 mm belt armor and design speed of 21 knots.³⁴⁸

In choosing a 35 cm main armament, the Navy abandoned pursuing of the smaller 34.5 or larger 35.5 cm guns and decided that the guns of the fu-

ture battleship would be yet another new caliber. The weight of the projectile of this gun was 635 kg.³⁴⁹ The protocol of the abovementioned board meeting does not explain the choice of the new caliber. Future researches may reveal the background of this decision. In July 1912 the Navy asked the Škoda to produce designs for the new 35 cm twin and triple turrets. On the order of the MTK's Artillery Department, headed by Kontreadmiral



46 Oberster Schiffbauingenieur Franz Pitzinger

	<i>MTK</i> 24,500 ton	<i>Danubius</i> 24,650 ton
Dimensions in m	173.2×28.5×8.4	167×29.2×8.3
Machinery	15 Yarrow boilers 2 sets of Parsons-turbines	15 Babcock-Wilcox boilers 2 sets of AEG-turbines
Power/speed in Hp/kn	31,000/21	32,000/21
Range in nm	6,000	6,000
Armor thickness in mm	300 belt 36 deck 340-80 turret 300 conning tower	300 belt 36-48-63 deck turret N/A 300 conning tower
Armament	10×35 cm/45 18×15 cm/50 20-22×9 cm/45 6×53.3 torpedo tubes	10×35 cm/45 18×15 cm/50 ?×9 cm/45 6×53.3 cm torpedo tubes

Emil Fath the Škoda returned to the simpler and more reliable fixed-elevation loading system.³⁵⁰

Austrian naval historian Erwin F. Sieche states that increase of the caliber by 0.5 cm was needed because it had to compensate the loss of armor penetration given by the new Einheitsgranate (a lighter type of APC projectile)³⁵¹ being developed. He also mentions a second possible reason but with question mark, that the Navy wanted to introduce the same caliber as the German Navy on the *Mackensen* class battlecruisers.³⁵² This seems less likely because Admiral Tirpitz, the head of the German Reichsmarineamt, really wanted a common caliber for the German and Austro-Hungarian battleships, but his candidate was the 38 cm caliber to match the latest British battleships. His later criticism of the second Austro-Hungarian dreadnought class was centering on the caliber of the main battery.³⁵³

In January 1913, the Navy via the Austro-Hungarian embassy in Berlin asked the permission of the German Reichsmarineamt to obtain price quotes for 35 cm twin and triple turrets from Krupp. The Austro-Hungarian Navy hoped that with the price offer from Krupp in their hand they could break down the overly high prices given by Škoda. The Reichsmarineamt gave permission but the Krupp did not produce the price quotes.³⁵⁴

In July 1912, the Navy asked the three shipyards and the MTK to formalize their designs on the basis of the new specifications. In the Kriegsarchiv, Vienna, in the files of the Präsidialkanzlei it can

be found only the Danubius design. Fortunately, a copy of the MTK's design was preserved in the Archives of the Hungarian Technical and Transport Museum.³⁵⁵ The MTK presented its design to the Navy in January 1913, the Ganz and Co Danubius in March of the same year. The MTK's design in fact was the slightly shortened (by 2 meters) variant of their 25,200 ton design armed with ten 35 cm guns. The belt thickness of this slightly smaller design was reduced from 340 mm to 300 mm. The lighter gun turrets and the reduction of belt armor thickness enabled MTK to save 600 tons. The MTK made two alternatives: the same ship with two triple and two twin turrets, but in the first alternative the twins were superimposed over triples, in the second alternative triples were superimposed over twins, as it can be seen on a drawing made by Škoda in June 1912. The first alternative had twenty and the second had twenty-two 9 cm anti-torpedo boat guns. From the first moment the Navy favored the first alternative. After October 1912, when the stability problems of the *Viribus Unitis* was discovered on her trials, superimposed triple turrets over twins seemed not a very good idea.³⁵⁶ The Ganz and Co. Danubius made only one design, without any reference to the arrangement of the turrets. On the evidence of the sketchy drawings of the shipyard it's impossible to establish of the precise arrangement of the turrets.³⁵⁷

The Danubius's ship was shorter and beamier, making for a more stable gun platform than the

Schlackbockbiss von 24500 t. Deplacement

Längenschnitt

Höhenmaß 1:500

Mit Änderungen nach Entlass $\frac{24}{105}$ Nr. 500 vom 26. April 1913
 Date, am Juli 1913.

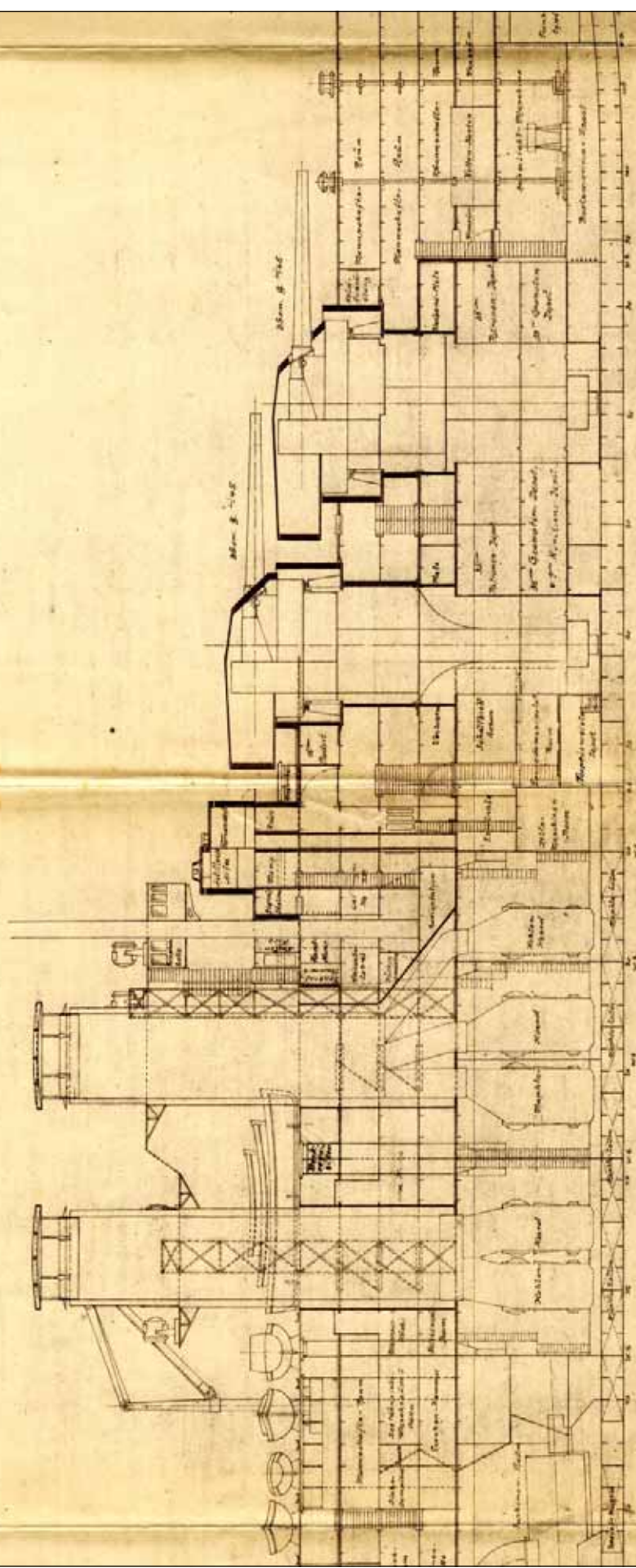

47 A part of the longitudinal section of the MTK's 24,500 ton design with the April 1913 modifications

MTK design. In her proportions she resembled contemporary German battleships. Her torpedo protection system was very interesting: instead of a single torpedo bulkhead it consisted of a second, internal, vertical double-bottom, with 45 mm (22.5+22.5) and 15 mm plating. The distance between the two plating was 700 mm.³⁵⁸ Distance between the ship's side shell plating and the 45 mm plating is unknown. The torpedo protection system of the MTK 24,500 ton design was similar to the former 25,200 ton design; only the torpedo bulkhead was thinner by 2 mm: a 36 mm (18+18) torpedo bulkhead run from the foremost to the aftermost gun turret and its distance from the side shell plating was 4 m. The space between the inner plating of the double hull and the torpedo bulkhead was filled with the reserve coal (170-170 tons). The torpedo bulkheads were strengthened by armored chambers on their inner side with the three coaling doors cut in the bulkheads on each side. On the basis of theoretical calculations this system would have provided four times greater resistance against underwater explosions than the system of the *Tegetthoff* class. Interestingly, the MTK stated that the layout of the torpedo protection system had been based on an article of Luigi Orlando published in the December 1911 issue of the Italian "Rivista Marittima". The watertight bulkheads were reinforced compared to the bulkheads of the *Tegetthoff* class and what is more important no watertight doors were cut in them. As the MTK stated these bulkheads could withstand the pressure without using timbers to support them.³⁵⁹

On 19 April 1913, a board headed by the Marinekommandant, Vizeadmiral (from 1 May full Admiral) Anton Haus decided for the final turret arrangement: twins superimposed over triples. The board on the same day rejected all the designs of the privately owned yards, giving solely in Pitzinger's and the MTK's hands the design of the future battleship.³⁶⁰ This time Franz Pitzinger, who favored his own design, won the battle over the privately owned yards and his predecessor, Siegfried Popper, to whom he had lost earlier in the case of the *Tegetthoff* class.

On 23 April 1913, the Navy ordered the MTK to rework the January 1913 design: after some weight saving modifications it had to thicken the armor of the belt, the barbettes and the conning tower. In addition, it had to completely redesign

the electric system of the ship. The matter was so secret that Pitzinger personally had to hand the new designs to Haus.³⁶¹

In the same order the Navy asked the MTK to elaborate preliminary designs for two enlarged battleships: a 29,600 ton ship with twelve 35 cm guns in four triple turrets, and a 32,000 ton ship with thirteen 35 cm guns in three triple and two twin turrets (similar to the Italian *Conte di Cavour* class). These ships should attain a speed of 23 knots, and their armor should be thicker than of the 24,500 ton ship.³⁶² Because in October 1913, it was decided that the Navy would build 24,500 ton battleships, on 20 October Haus asked Pitzinger to make only sketch designs.³⁶³ The MTK presented the two designs with two series of 1/200 scale drawings in January 1914, but these designs soon were shelved.³⁶⁴

On 4 August 1913, Pitzinger presented the modified 24,500 ton design to Haus. The armor of the casemates was reduced from 180 mm to 150 mm, and the bow armor from 150 to 140 mm. Of the weight saved the armor of the conning tower and the barbettes was increased from 300 to 320 mm and the thickness of the belt was increased to 310 mm. The armor thickness of the lower part of the conning tower was also increased from 150 to 280 mm. At the request of the Navy the ammunition allowance per gun of the 35 cm guns was increased from 76 to 100 rounds. For this reason, it had to redesign the magazines, the shell rooms and the lower part of the gun turrets and it had to abandon the projected mine room for 20 mines. The cramped machinery rooms were slightly enlarged which made possible the reduction of the revolution of the steam turbines from 320 to 300 rpm.³⁶⁵

In October 1913, the Navy decided for a new arrangement of the 9 cm guns and ordered the MTK to elaborate alternatives for increasing the bow fire. On 31 October, the MTK presented three alternatives. The Navy chose the third alternative and a casemate of two 9 cm guns was installed under the forecastle deck in the crew compartment on each side of the bow.³⁶⁶

After the authorization of the new extraordinary credit for the Navy by the common Council

Opposites page:

48 The MTK's 32,000 ton design armed with thirteen 35 cm/45 guns in five turrets

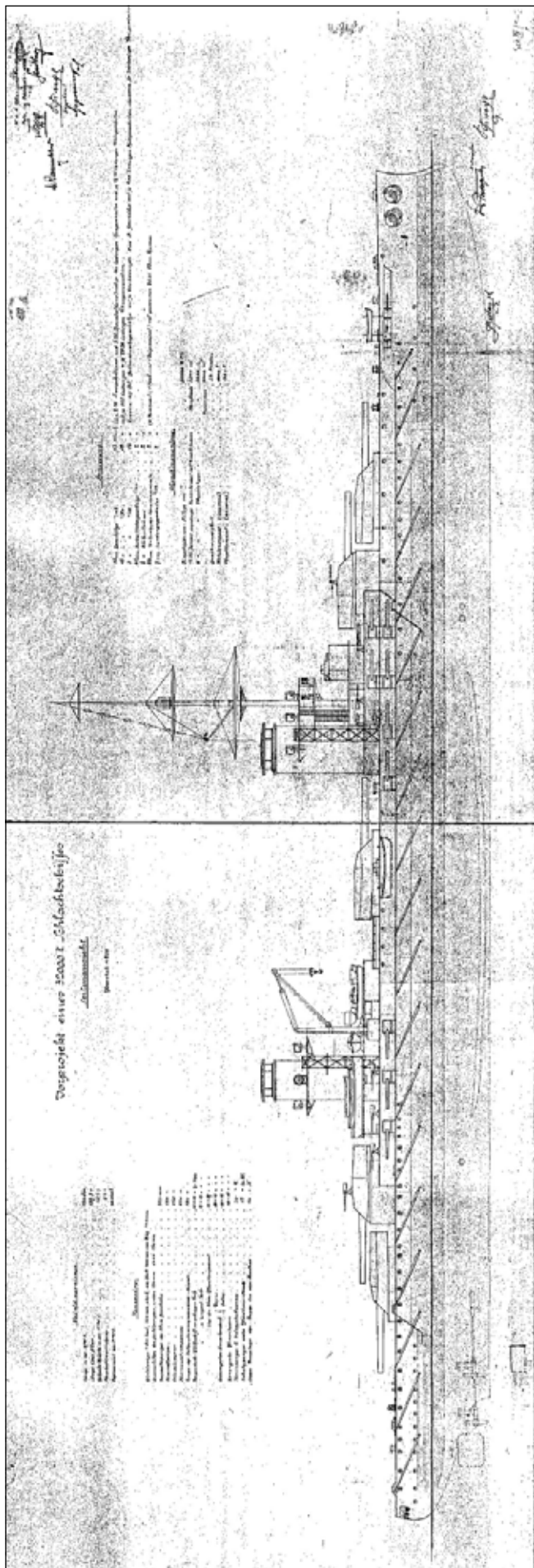

of Ministers in October 1913, the Navy started negotiations with the representatives of the three shipyards on the technical and financial questions of the building program. At the 1 December meeting of representatives of the Navy and of the STT a short but bitter battle of words took place between Pitzinger and the director of the yard, Gustav von Lehndecke who represented the opinion of Popper over the torpedo protection. In essence Pitzinger accused Popper of designing a flawed torpedo protection system for the *Tegetthoff* class. The representatives of the STT stated that the machinery rooms of the design were too cramped, the machinery engineers of the MTK vehemently tried to refute this assertion. At the end of the meeting, it was mentioned that it should slightly redesign the foremast and the searchlight elevators because on the roof of the conning tower a larger, 5 m base length rangefinder would be installed.³⁶⁷ Beside the price calculation the works on the detailed design started after this meeting.

In February 1914, the designs were circulated among the different departments of the Marinesektion. The 4th department of the II Geschäftsgruppe commented the design,³⁶⁸ and an elaborate note was written on the artillery to be used on future battleships.³⁶⁹ The authors of both documents agreed that the upper 15 cm casemate (Rduit) around the conning tower was unnecessary and proposed its abandonment. They also agreed that due to the projected installation of two full sets of Pollen fire control system per battleship it would be necessary bringing back the aft fire control tower cancelled in 1912. However, they added that they knew that it was impossible on weight grounds. The writer of the note on the artillery suggested considering the possibility of using hydraulic turret machinery despite its greater weight. The 4th department proposed considering the use of geared steam turbines, and called for using of the results of the underwater explosion test and the so called caisson test to be executed.

The Arsenal of Pola also commented on the designs. They considered that the protection of the magazines of the two triple turrets was insufficient. As on the *Tegetthoffs*, on the 24,500 ton design the casemate armor ended at the superimposed turrets, so over the magazines of the foremost and the aft-most turrets the reinforced Mitteldeck (30 mm) provided some extra protection counterbalancing

the lack of vertical armor over the main belt. Based on their calculations they stated that a heavy projectile arriving at an angle of 7 degrees or more could slip above the main belt and easily penetrate the 30 mm thick Mitteldeck and the 36 mm thick armored deck one level below and reach the magazine (cartridge room). On the 24,500 ton design, unlike on the *Tegetthoffs*, the 35 cm magazines were directly below the armored deck and their upper parts were above the waterline.³⁷⁰ The Arsenal proposed thickening the Mitteldeck over the magazines of the triple turrets to 50 mm. To compensate the extra weight, they also proposed the abandonment of the upper casemate.³⁷¹

Pitzinger in his 27 March report to the Marine-sektion reflected only on the Arsenal's proposal. He stated that the thickening of the Mitteldeck by 20 mm would result in reducing the thickness of the main belt, the barbettes and the conning tower to 300 mm.³⁷² It is clearly visible that Pitzinger was sticking to the upper casemate around the conning tower and its four 15 cm guns and was reluctant to sacrifice it, but the days of the *Reduit* were numbered.

There were many problems with the *Reduit*, or upper casemate. The foundations of the pivots of the 15 cm guns were weak, the ammunition supply of the guns was difficult and the fore triple turret could block the fire of the *Reduit's* guns when it was trained to starboard or portside. Due to these problems on 15 April 1914 the Navy finally decided to abandon the upper casemate. With this decision the number of 15 cm guns was reduced from 18 to 14.³⁷³ The 470 tons weight saved by the elimination of the upper casemate was spent on armor thickening and structural reinforcements. The Mitteldeck over the magazines of the two triple turrets, which was an area of 1,050 square meters, was thickened from 30 to 50 mm. The armor of the barbettes between the armored deck and the Mitteldeck was reinforced, its thickness increasing from 80 to 110 mm. The transversal armored bulkheads were also reinforced as were the foundations of the conning tower and the twin turrets. The 11 mm plating of mild steel (*Schiffbaustahl*) was changed to 40 mm reinforced plating of K armor above the bow and stern armor ranging to the portholes. The 35 cm ammunition allowance per gun once augmented from 76 to 100 rounds was reduced again to 76 due to lack of space.³⁷⁴ One of the reasons of the

latter was the redesign of the broadside torpedo tube rooms to accommodate the longer 7 m type torpedoes.³⁷⁵

When the delegations voted for the extraordinary credit in May 1914, the final design was ready to approve, with only one great test still remaining: the underwater explosion test on a test bed which represented the 1/1 scale midship section of the projected battleships.

The Underwater Explosion Test

It is matter of common knowledge that the deficiencies of torpedo protection system of the *Tegetthoff* class dreadnoughts moved the Austro-Hungarian Navy to carry out expensive underwater tests following the German example.³⁷⁶ To evaluate the layout of torpedo protection (torpedo bulkhead, armored deck) a 1/1 scale test bed, a hull middle section, the so called *Sprengobjekt* (explosive object) was constructed. All test reports were, however, disappeared from the *Kriegsarchiv* Vienna, allegedly an Allied fact finding team of unknown nationality carried them away and consequently the results of the test remained unknown for a long time. Fortunately, in the Archives of the Technical and Transport Museum of Budapest, some documents of the abovementioned underwater test were found including the test report.³⁷⁷

When Haus replaced Montecuccoli as Marinekommandant the Navy recognized the immense importance of the underwater protection against naval mines and torpedoes. In the light of the well-known defects of the torpedo protection system of the *Tegetthoff* class battleships now under construction the Navy was no longer satisfied with theoretical calculations and useless experiments on models. In 1913, the Navy decided, possibly on Haus's direct order, to execute an expensive underwater test on a test bed representing a 1/1 scale of the battleships to be built. It was a reasonable decision because the less than quarter million Kronen cost of the test was a fraction of the 328 million Kronen price of the four battleships all the more so because the test results could save an expensive battleship from sinking.

The test on a 1/1 scale section of the 24,500 ton battleship was ordered by the Navy on 9 September 1913. The MTK completed the plans for

Sprengobjekt.

Marinetechn. Komitee
Im Juni 1904.

1:100

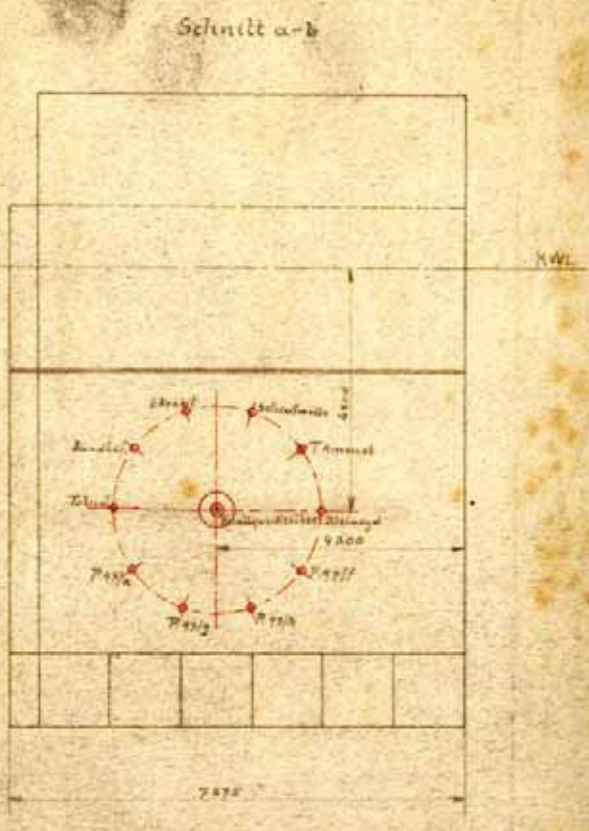
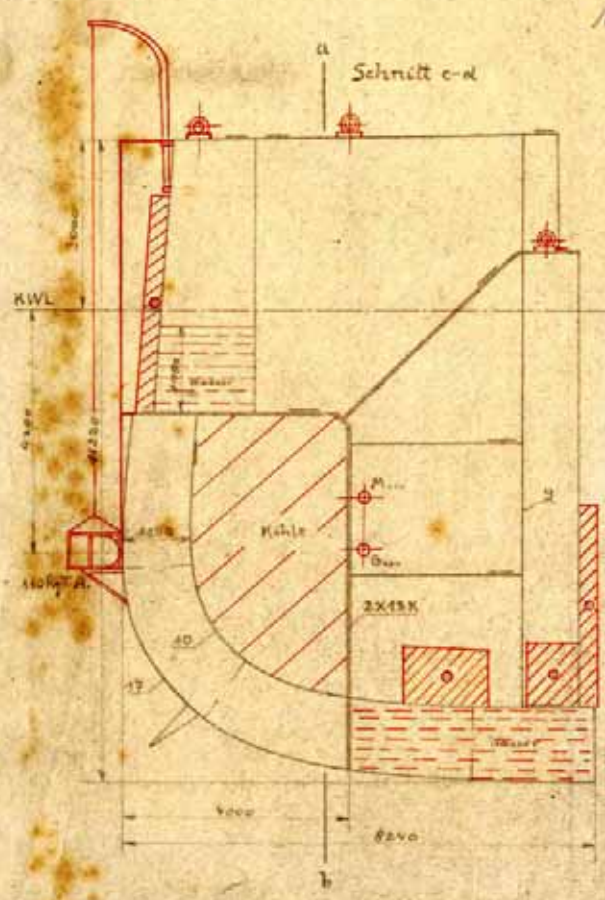

Draufsicht

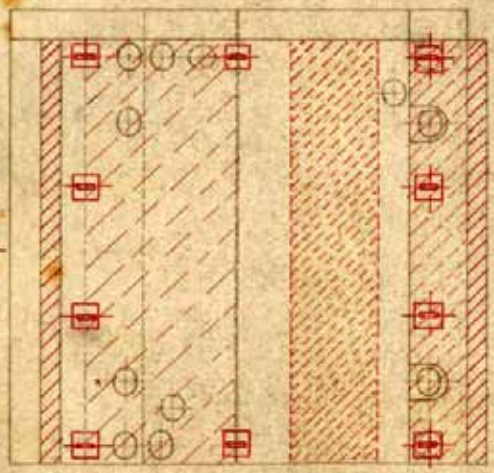

NB. Sprengstoffe auf der Innenbordseite der Minenschielle.
Sprengobjekt ist im Val Maggiori in ca. 25m Tiefe verankert zu verbleiben.

M. Maggiori

49 The plan of the Sprengobjekt, the test bed for evaluating the torpedo protection system of the 24,500 ton battleship design

the 450 ton *Sprengobjekt* by November 1913. The 7.87 m long, 8.24 wide and 11.22 m high *Sprengobjekt* represented a six frame-long boiler room section of the 24,500 ton battleship. The empty weight of the *Sprengobjekt* was 133 tons, 61 tons of armor plates represented the belt and 51 tons of armor was used on the other side as counterbalance. The space between the torpedo bulkhead and the double hull contained 64 tons of coal (briquette). 87 tons of additional ballast and 54 tons of water were in the double bottom and double hull cells to trim the *Sprengobjekt*. The written documents mention a coaling door cut in the torpedo bulkhead, but this door not visible on the plans.³⁷⁸

During the preparation work for the test, the Marinesektion asked the Germans for detailed information on the German tests. In their answer of January 1914, the Germans said that they would transfer data only if the test would be carried out in accordance with German specifications. The MTK concluded that in this case it had to construct a *Sprengobjekt* nearly twice as large as originally planned. The MTK put forward a compromise proposal to carry out two tests, one with the original and one with the larger test bed, the latter test with a greater explosive load. On 8 April 1914, Haus decided to execute the test as originally had been planned. He explained his decision with the shortness of time and with the lack of the Navy's means to salvage the larger test bed after the test.³⁷⁹

It was originally planned that the test would be executed by a naval mine simply bolted to the side shell plating 4.2 meters below the waterline, but the 8 March 1914 order of the Navy decided instead for a 45 cm torpedo warhead filled with 110 kg T-Ammonal (amatol). The torpedo warhead could be lowered in a cage on two vertical rails by a davit. The Navy also wanted to examine the impact of the detonation on different explosives and propellants, so for this purpose sixteen small metal boxes filled with different types of M/97 propellant, TNT, ecrasite, etc., were bolted to the inner side of the torpedo bulkhead.³⁸⁰ The *Sprengobjekt* was built in the Pola Arsenal in the late spring of 1914.

On the order No 157 of the Hafenamiralität (Harbor Admiralty) of Pola of 6 June, the test was executed at 2 p.m. on 10 June 1914. In the morning of 10 June, the *Sprengobjekt* was towed from the Arsenal to the Valmaggiore Bay where it was moored 3.1 km from the pier from which the committee

observed and filmed the experiment. At 2:30 p.m. the warhead was ignited by an electric cable. The splash caused by the explosion was 70 m high. The *Sprengobjekt* sank in 28 minutes. On the next day the wreck lying on the seabed was examined by a diver. On 15 June, the wreck was salvaged by the 240 ton floating crane of the Arsenal and was carried to Dock No 22 for examination.³⁸¹ It's more than probable that the experienced naval architects and engineers of the MTK and the Arsenal saw at the first glance that the experiment was successful and the protection system worked well. It is almost certain that they immediately informed Haus and the Marinesektion of the success of test. The wreck of the *Sprengobjekt* was thoroughly examined and the committee made its report on 3 July.

The committee pointed out in its 3 July official report that the test was a definitive success, as the torpedo bulkhead and the armored deck remained watertight. The lower layer of the armored deck was tore away by the explosion over the double hull, but the upper layer remained watertight. The armored deck over the reserve coal bunker remained almost intact deforming only slightly. This throws light upon the other, less known deficiency of the underwater protection system of the *Tegetthoff* class discussed in details in the chapter on the given battleships. The explosion caused only small dents (max 80 mm) in the torpedo bulkhead. The armored coaling door cut in the torpedo bulkhead also remained watertight. The propellants and the explosives attached to the inner side of the torpedo bulkhead did not explode. The brief summary of the test report stressed: "On the basis of the experiment it can be stated that a ship constructed this way will not be endangered by a 110 kg 45 cm torpedo warhead and the resulting list of 2 degrees can easily be compensated."³⁸²

In 1914, the Navy also conducted so-called "caisson tests". The main purpose of these tests was obtaining data for more precise calculations which would help to design improved watertight bulkheads. The tests were executed on the ½ scale models of the watertight bulkheads used on the *Tegetthoff* class. The test results were not very promising for the *Tegetthoffs*: converting the data to 1/1 scale bulkheads the engineers of the MTK came to the conclusion that the pressure of a 5-6 m high water column could cause a 30 cubic meters per hour leakage through the bulkhead.³⁸³

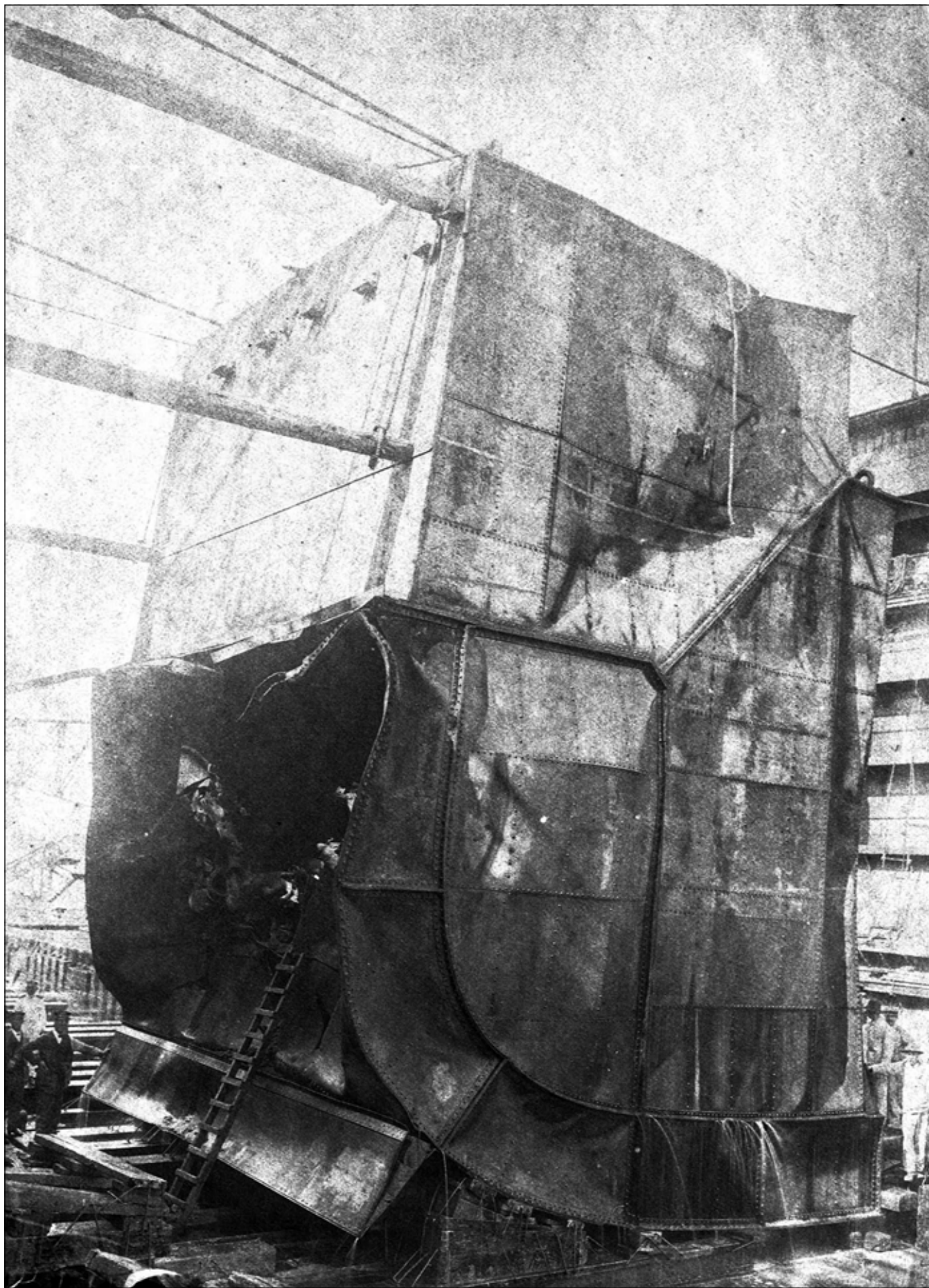

50 The salvaged Sprengobjekt after the test in the Floating Dock No 22

The Final Design

After the successful underwater explosion test, MTK worked on improving their design. Ironically, on the same day as the assassination of Franz Ferdinand and his consort in Sarajevo, the MTK presented to the Navy their final version of the design of the 24,500 ton or "*Improved Tegetthoff*" class battleship. The design was approved by the Navy on 1 July.³⁸⁴

The "*Improved Tegetthoff*" class represented a more balanced design than the *Tegetthoff* class. This design was not overloaded by the main armament therefore it was more stable thanks to the lower center of gravity. The raised forecastle helped to improve her expected seagoing performance. Furthermore, the crew compartments were more spacious in these ships compared to the earlier battleships. The survivability of the 24,500 ton design was largely improved compared to the first dreadnought class due to the improved torpedo protection system, the better compartmentalization of the hull under the armored deck and the thicker armor.

The displacement of the "*Improved Tegetthoff*" class was by 4,500 tons or 22.5 percent larger than the displacement of the *Tegetthoff* class. The greater part of the increase was dedicated to protection and survivability. The weight of the vertical armor was 1,300 tons or 26 percent greater, the thickness of the belt armor was increased by 10 percent (from 280 to 310 mm) while the thickness of the casemate armor was decreased by 17 percent (from 180 to 150 mm). The weight of the hull (including watertight bulkheads) rose from 5,313 tons to 7,094 tons (33 percent), which indicates the intention of

the designers to create a much stronger hull structure. The weight of the main battery including gun turrets rose only slightly, from 2,798 tons to 2,914 tons, while the weight of a broadside rose from 5,400 kg to 6,350 kg. The design speed of the new battleships was 21 knots or 1 knot more than that of the preceding two classes. The specific (per ton) price of the new battleships also rose by 12 percent from 3,000 to 3,360 Kronen

Seven years after the preceding decision, in 1911 the Navy decided again for introducing a new caliber. In the summer of 1912, it was decided that the main armament of the new battleships would consist of ten 35 cm/45 guns mounted on two triple and two twin turrets. The 635 kg projectile of this gun was 41 percent heavier than the 450 kg projectile of the 30.5 cm/45 gun. There are no actual test results available, only theoretical calculations, on the basis of which we can suppose that the armor penetration capability of the 35 cm APC would have exceeded by approximately 15 percent that of the 30.5 cm APC. The Navy also decided for the first time in its history to introduce for this gun a light APC projectile (Einheitsgranate), which armor penetration capability would have been theoretically equal to that of the 30.5 cm APC. The large ammunition hoists of the 35 cm turrets (length of the hoist car was 1,500 mm) could handle projectiles fitted with 5.25 crh ballistic cap.

In June 1912, the Navy abandoned pursuing the idea of any-angle loading. This decision made possible reducing the barbette diameter of the 35 cm triple turret from 11.2 m to 10.3 m. The barbette diameter of the twin turrets was still 560 mm (8500 mm) greater than that of the British 34.3 cm

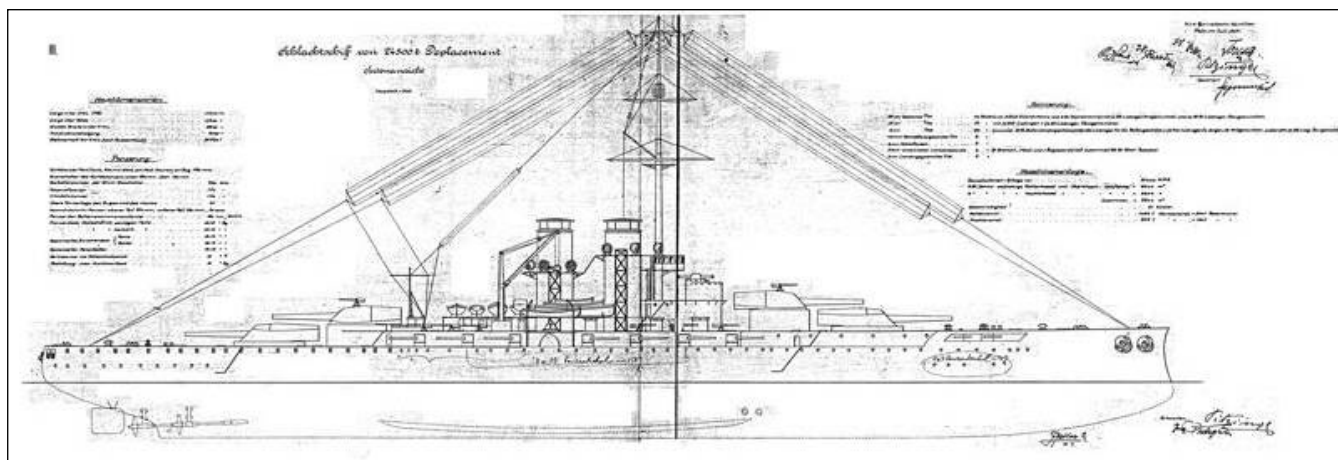

51 The final design of the "*Improved Tegetthoff*" class battleships from June 1914 without the upper casemate around the conning tower

turrets.³⁸⁵ The new turret designs, thanks to the fixed loading angle, were lighter despite the heavier, larger caliber guns mounted on them and their thicker turret armor. The few plans available show that the elevation range of these guns was $-4/+16$ degrees. Probably the Navy intended to construct these turrets with the same sort of couplings as used on the 30.5 cm triple turrets. On the evidence of the 24,500 ton battleship plans these turrets would have had interrupted ammunition hoists and a handling room two levels below the gunhouse. Contrary to the preceding classes, the shell rooms and magazines would have been on different levels, magazines above the shell rooms, directly under the armored deck. This arrangement resulted in the upper part of the magazines being over the waterline, but the Navy did not worry much about this, because this practice was acceptable also in the German Navy.³⁸⁶ These turrets would have been fitted with 5 m rangefinders under the roof armor, looking out through periscopes protected by small armored hoods.

The secondary battery of the final design consisted of fourteen 15 cm/50 guns in casemates, eight of them firing forward and six firing rearward. The fire control stations of the 15 cm batteries were integrated into the casemates. The light anti-torpedo boat battery consisted of twenty 9 cm/45 guns with twelve of them being dual purpose guns with AA capability. The battleships had six 53.3 cm submerged torpedo tubes, one in the bow, one in the stern and two-two in the broadsides.

We know little about the fire control system which was to be fitted to these battleships. Official documents suggest that the Navy planned to equip each ship with two full sets of the Pollen fire control system. The conning tower differed from the ones of the *Tegetthoffs* and its design was similar to the ones on the contemporary German dreadnoughts. The main fire control position was accommodated in the aft part of the conning tower and it had a low armored cupola on the roof with slit windows. On the top of this cupola a rangefinder was fitted in a smaller, revolving armored cupola. The "*Improved Tegetthoff*" class battleships did not have aft conning towers on weight saving grounds. The aft fire control position was in the aft superimposed gun turret.³⁸⁷ The ships had seven rangefinders: one 5 m on the roof of the conning tower, four 5 m under the gun turret roofs and two of unknown base

length on the roofs of the 15 cm fire control positions. Unlike their predecessors, these ships had a single mast which was a simple pole foremast with an open "crow's nest" as firing observation station. The mainmast was omitted not on weight saving grounds but because the MTK intended to prevent damages which a collapsing mast could cause. The final design was fitted with a small mainmast, much lower than the foremast to facilitate connecting the radio-room to the radio antennas.³⁸⁸

Compared to the *Tegetthoffs*, the weight ratio of the armament especially of the gun turrets of the 24,500 design was lower: the weight of the gun turrets was 11.9 percent instead of 14 percent of the displacement. Therefore, the greatest part of the 4,500 tons increase of the displacement was spent on the armor and improved survivability, only a small part of it was dedicated to the increase of firepower and speed. The lighter superimposed gun turrets had a good effect on stability as the new battleships had a lower center of gravity and larger metacentric height.³⁸⁹

The weight of the vertical armor was 6,317 tons. The main belt was 310 mm thick tapered to 180 mm under the waterline. Forward of the barrette of the first 35 cm turret the belt reduced in thickness down to 110-140 mm, and aft of the barrette of the fourth 35 cm turret to 200 mm. The upper belt and the casemate armor was 150 mm thick. The armored deck was 36 mm thick. In addition, over the 35 cm magazines of the lower (triple) turrets, the Mitteldeck was 50 mm thick. The barbettes of the 35 cm turrets were 320 mm thick above the Oberdeck and 280 mm between the Mitteldeck and the Oberdeck. The barbettes were 110 mm between the armored deck and the Mitteldeck. The faces of the turrets were 340 mm thick, the sides of the triple turrets were 300 mm and the sides of the twins were 250 mm thick. The roofs of all turrets were 80 mm thick. The conning tower had 320 mm thick sides and 60 mm thick roof.

The torpedo protection system of the final 24,500 ton design was much better than that of the first dreadnought class. The system was 4 m deep instead of the 2.5 m of the *Tegetthoff* class and successfully tested in June 1914 on a 1/1 size middle section (*Sprengobjekt*). The thickness of the torpedo bulkhead was 36 mm. The thickness of the armored deck which closed the system from above and which was horizontal in this area was also 36

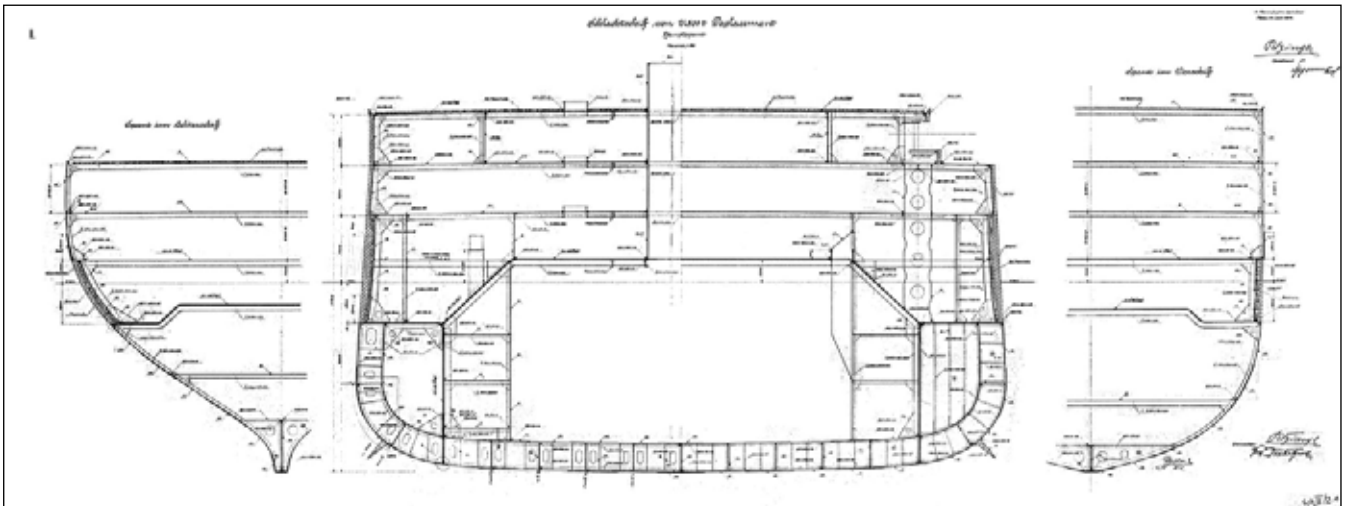

52 Midship section of the 24,500 ton battleship design; the depth of the torpedo protection system is 4 m

mm. The construction of the 21 watertight bulkheads was stronger than on the *Tegetthoff* class. While the distance between the vertical stiffeners of the bulkheads was somewhat greater (625 mm), the steel L profiles themselves were much stronger than on the preceding class. These bulkheads had also two horizontal stiffeners. Only two watertight doors were cut in the bulkheads, one in the bulkhead which separated the two broadside torpedo rooms and one in the bulkhead between the two aft dynamo rooms. The MTK stated that the bulkheads would hold without the excessive use of supporting timbers.³⁹⁰

The “*Improved Tegetthoff*” class would have been the first Austro-Hungarian battleship with a raised fore-castle deck. The raised fore-castle deck would have provided better seagoing performance and more accommodation space for the crew. The length-to-beam ratio of the hull was 6.07:1, which was considerably larger than the 5.43:1 of the *Tegetthoff* class. The larger beam ratio was favorable for attaining greater speed. Thanks to the lighter main armament and the fact that twin turrets were in the superimposed position instead of triple turrets, the center of gravity was 1.289 m over the waterline instead of the 1.789 m of the *Tegetthoff* class and the metacentric height was 1.886 m instead of 1.101 m, which would have provided better stability to the new class. To reduce the risk of deformation of the rear part of the hull while docking, the upward inclined part of the keel at the stern was 17 m long instead of 27 m.³⁹¹

The design weight of the machinery complex of an “*Improved Tegetthoff*” class battleship was 1,830

tons. The machinery consisted of two sets of direct drive³⁹² Parsons-turbines (Danubius AEG-Curtiss) without cruising turbines, nine coal firing with oil spraying and six oil firing water tube Yarrow (Danubius Babcock-Wilcox) boilers. The design power output of the machinery was 31,000 SHP and the design speed of the ships was 21 knots. Each of the two stages (HP, LP) of the two sets of turbines drove a three-bladed manganese bronze screw. The machinery room was subdivided into four compartments the turbine room was subdivided into three compartments by two longitudinal bulkheads, while the main condensers were in a fourth compartment aft of the turbines. The fifteen boilers were arranged in three boiler rooms, three coal firing boiler in a row in the first, six oil firing boilers in two rows in the second and six coal firing boilers in two rows in the third. The first and the second boiler rooms had a common funnel, while the third one had its own. The ships could carry 1,425 tons of coal and 1,035 tons of fuel oil which enabled a maximum range of 6,000 nautical miles at a cruising speed of 10 knots.

In international comparison the fighting value of these battleships would have been approximately equal to the British *King George V* and *Iron Duke* (23,500 and 25,000 tons, 10×34.3 cm) classes of 1911-1912. On the Mediterranean they would have been fine ships, clearly better than the French 34 cm *Bretagne* class of 1912. Their greatest disadvantage was the fact that they would not have been in the same league with the new Italian battleships to be built, the *Francesco Caracciolo* class (31,400 tons, 8×38.1 cm, 25 knots). These Italian

ships would have been the enlarged copies of the British *Queen Elizabeth* class fast battleships. Most probably the units of the *Francesco Caracciolo* class were the “super-dreadnoughts” in the 1913 October article of the “*Neue Freie Presse*” which criticized the Navy’s 24,500 ton battleship design.³⁹³

Political and Financial Background

The struggle of the Navy for securing the money for the new battleship class started in March 1912. Marinekommandant Admiral Rudolf von Montecucoli presented a very ambitious (in fact, the most ambitious in the history of the Navy) program in March 1912: he asked a grant of 464 million Kronen. This sum would have allowed the construction of four 24,500 ton battleships, five cruisers, a dozen destroyers, six submarines, three colliers, a new 40,000 ton floating dock, four Danube monitors and four Danube patrol boats. The Emperor, Franz Joseph was realist and advised him to present his program at a more favorable time.³⁹⁴

At the 9 July meeting of the common Council of Ministers, Montecucoli asked only 24 million Kronen for starting the construction of one new battleship. The Hungarian members, Prime Minister László Lukács and Finance Minister János Teleszky, rejected even this modest sum. On 3 October, Montecucoli asked 170 million Kronen for the construction of two 24,000 – 25,000 ton battleships. On 8 October, Lukács and Teleszky told him that they would assent to the costs of the new class only if the precedent one would be paid, but they promised to bring forward the payment from 1916 to 1914. The Hungarian government approved only the construction of two colliers.³⁹⁵ Anton Haus as the newly appointed Flotteninspektor on 25 July 1912 visited Franz Ferdinand in Chlumetz. At this introductory meeting, the Heir of the Throne expressed his wish to start the building of the new battleships as soon as possible. He told Haus to convene a common Council of Ministers and to build the battleships even if financing was “from the air”.³⁹⁶

In February 1913, the old and compromised Montecucoli was succeeded by Anton Haus. In March 1913, Archduke Franz Ferdinand, who wanted to repeat the method to start the construction at the formal own risk of the shipyard STT

before the voting on the expenses of the battleships like in the case of the *Tegetthoff* class, urged Haus to order the new dreadnoughts secretly without informing the Austrian and Hungarian politicians.³⁹⁷ Despite the great pressure from the Archduke, Haus did not want to go behind the backs of the politicians and in April he started negotiating with Austrian and Hungarian ministers on this method of building.

On 18 April 1913, the STT, the Škoda Works and the Witkowitz Ironworks in a joint letter offered to start the construction of a battleship on designs provided by the Navy at their own risk. The three firms asked for orders, claiming otherwise they should begin to dismiss qualified employees from the second half of the year. In the official documents this method was called “*Spekulationsbau*”. The Navy made two preliminary draft replies. The first was an enthusiastic version for the case if both governments would assent to the building at formal own risk. The first line of this variant is the following: “My predecessor already expressed before the delegations in December 1912 that the *Monarch* class should be replaced with dreadnoughts.” According to this variant the Navy would have provide the three firms with the plans of the 24,500 ton battleship for price calculation. The second version was less enthusiastic. In this variant the Navy emphasized that under the circumstances they could not give an order or could not make a commitment. Both variants included a paragraph which called the attention of the three firms to the orders to be provided for the Hungarian industry.³⁹⁸

On 20 April 1913, Haus met Lukács in Vienna and gave him an exemplar of the abovementioned letter of 18 April and the less enthusiastic version of the preliminary draft reply. The Hungarian Prime Minister thanked the fairness of Haus. Lukács told Haus that he was hearing rumors of this matter since a month, and the members of his cabinet were very anxious about this matter. Haus felt that he was justified and the secret-mongering pressed by the Heir of the Throne was a blunder. The common ministers, common War Minister Krobotin, common Foreign Minister Berchtold and common Finance Minister Biliński supported the plan of building at the formal own risk, but the Austrian Prime Minister Stürgkh and Finance Minister Zaleski were not too enthusiastic. Zaleski

told that under such demands the budget easily could collapse.³⁹⁹

On 25 April, Teleszky in a letter to Biliński refused the plan and said no to the *Spekulationsbau*.⁴⁰⁰ The Hungarian Finance Minister said that the *Spekulationsbau* would violate the legislation's budget rights. He added that this method of ordering without legal authorization a battleship to be constructed to the Navy's own design and specifications could be very risky because she could be sold to a foreign power. He said that the temporary lack of orders of the three firms had been caused by Montecucoli's policy, when the Navy had ordered the first two units of the *Tegetthoff* class before the voting of the expenses of the class. Finally, he remarked that this matter was also dangerous from economic point of view because both in Austria and Hungary at that moment the credit market was under strain.⁴⁰¹ On 28 April, Biliński informed Haus of Teleszky's letter. An angry Haus noted in his diary: "Stürghk is a windbag, Biliński is a kind, good, optimistic nobleman who bids more than he can accomplish, Teleszky is a Jew, Lukács is disingenuous, cunning, a dog."⁴⁰²

On 30 April, Franz Joseph promised Haus that he would speak about the battleships with Teleszky. On 1 May, even the Emperor tried to convince the Hungarian Finance Minister in vain. After this audience Haus negotiated with Teleszky who only repeated his former arguments. Haus told Teleszky that starting the construction of the new battleships as soon as possible was very important, because in three or four years the Dual Monarchy would likely struggle for its life. Teleszky replied him that with the changing of the fiscal year the delegations could vote for the battleships in the spring of 1914, so the difference of the legal and the extralegal start of the construction would be only eight months. A decision was made in 1913 to change the Austro-Hungarian fiscal year from January-December to July-June. The first full fiscal year on the new calendar would begin in July 1914. On 7 May, Lukács sent a letter to Haus in which he explained that the political and economic situation in Hungary did not make it possible to support the construction of a battleship at the formal own risk of the shipyard. He added that any kind of orders given to the shipyard from the Navy should be considered as a formal order, thus the violation of the legislation's budget right.⁴⁰³

At the 14 May meeting of the common Council of the Ministers, Haus made a last effort to have his plan accepted. The common and the Austrian ministers supported him, but the two Hungarian ministers refused the plan again. Beside the economic arguments Lukács enumerated political ones. He said that even in his own Party (*Nemzeti Munkapárt*⁴⁰⁴) would not be able to defend the building at the formal own risk. Teleszky repeated his promise to bring forward the new credit from 1915 to 1914. Haus asked Lukács, what would be the consequence if the Navy tried to start the construction. Lukács replied: he and Teleszky should resign.⁴⁰⁵

At the 19 May audience Haus informed Franz Joseph about what had happened at the common Councils of Minister on 14 May. The Emperor advised the *Marinekommandant* not to provoke the Hungarian government. Franz Joseph agreed with Haus about not going behind the backs of the politicians and not to compromise the Navy.⁴⁰⁶ The matter of the new battleship class came to a standstill which lasted until October 1913.

Haus, as *Marinekommandant*, had many troubles with Archduke Franz Ferdinand who was the chief patron of the Navy but who was always interfering in the affairs of the Navy in a narrow-minded manner.⁴⁰⁷ The greatest friction between them was caused by the question of battleship building. After the fiasco at the meeting of the common Council of Ministers, Haus, who in these times played with the idea of resignation,⁴⁰⁸ wrote a long letter to the Heir of the Throne in which he explained away his report. He described in all details the events of April and May and pointed out that the delay of the construction in fact should be only one month instead of six or seven, because the time needed to draw up the detailed plans for the new battleships. Haus added that even the Emperor had advised not to provoke the Hungarian government because their resignations could rebound on the Navy.⁴⁰⁹ The latter argument due to Franz Ferdinand's negative feelings toward the Hungarians possibly only angered him.

During the summer of 1913, important changes occurred in the Hungarian politics. It turned out that Lukács as finance minister in 1910 had received 4 million Kronen from the Magyar Bank which he had given to the *Nemzeti Munkapárt* for funding the campaign of the Party in the 1910 election.

Zoltán Désy, an opposition MP called Lukács the “Greatest Panamist of Europe⁴¹⁰”. Lukács lost a libel action against Désy and he and his government resigned. Franz Joseph appointed István Tisza to prime minister in June. Tisza appointed Teleszky to finance minister again. Tisza, in contrast to many of his countrymen, considered the development of the common armed forces important because he knew well that the Great Power status of the Dual Monarchy was a key factor of the conservation of the Hungarian supremacy in the Carpathian Basin. It was evident also that the Hungarian government would expect lucrative industrial orders in exchange for the support of the Navy’s program.

At the 1 October 1913 audience Haus informed the Emperor about the particulars of the extraordinary credit. The moment of victory for Haus came at the 3 October meeting of common Council of Ministers. All the ministers, including the new Hungarian Prime Minister, Count István Tisza and Teleszky approved the new extraordinary credit of 426.8 million Kronen which included the cost of a new battleship class of four units. It was decided that credit should be lent from the 1914-1915 fiscal year to the 1918-1919 fiscal year. The 426,836,000 Kronen extraordinary credit provided the costs of four 24,500 ton battleship (*Schlachtschiff VIII-XI*) at 81.5 million Kronen for each unit, three 4,800 ton cruisers (*Kreuzer K, L, M*), six 800 ton destroyers, two 520 ton monitors and a food transport ship. The full cost of these ships was 400 million Kronen. The greatest part of the remaining 27 million Kronen was intended for land constructions in the Arsenal, 4 million for naval aviation and 1.1 million for the Radio Station Pola.⁴¹¹

After the 3 October meeting of the common Council of Ministers, the news of the extraordinary credit and the new battleships should have remained in secrecy, but the always well informed Vienna newspaper “Neue Freie Presse” published an article on the second dreadnought class along with some criticism. The author of the article wrote that the Dual Monarchy built only “dreadnoughts” while other powers laid down “super-dreadnoughts”. Haus felt that he had to defend his battleships. In a short communiqué he explained that the 35 cm main caliber of the battleships was the result of a compromise because in contrast to other naval powers the Austro-Hungarian Navy did not possess limitless resources.⁴¹²

For the privately owned shipyards, the question of the design was only a question of prestige, from the business point of view the real important question was: who should build these ships? Hearing the news of the voting of credit the representatives of the three shipyards hurried to Vienna. In the second half of October the Navy sent the designs to the STT, the CNT and the Ganz and Co. Danubius for price calculation.⁴¹³ The agents of the CNT were the most aggressive. Seeing this, the Hungarians were afraid of being left out of the battleship building program. But their fears proved to be baseless: the Navy knew full-well that due to the political system of the Dualism the price of the Hungarian votes for the credit was that an order of battleships must be awarded to the Danubius shipyard, despite the problems with the construction of the *Szent István*. Hungarian Finance Minister Teleszky in 1913 clearly let the Navy know what the Hungarians expected in exchange of voting for the credit.⁴¹⁴ In January 1914, Hungarian Prime Minister István Tisza asked Haus whether the CNT would participate in the battleship building or not. On 27 January, Haus reassured Tisza that the Navy would order battleships only from the STT and the Danubius.⁴¹⁵

Before the voting for the credit in May 1914, in February-March the Navy made a study on the possible sharing of the industrial orders of the new program between Austria and Hungary, respective to the Quota (Austria 63.6 %, Hungary 36.4 %). According to that study two battleships, one cruiser and six destroyers and two monitors, or two battleships and two monitors should be ordered from Hungarian industry. The Navy liked neither variants, the first one contained too high a number of ships to be ordered from Hungarian shipyards, while in the second one was too high a volume of orders to the Hungarian iron industry. In the case of the first variant, the Navy feared that the Danubius would be unable to keep the time limits and the Hungarian shipyard would siphon off experienced workers from the Austrian yards. In the case of the second variant, the Navy knew that without a huge order to the Hungarian iron industry as compensation (17 million Kronen) it would be unacceptable for the Hungarians, but they also feared, not entirely without cause, that the Hungarian iron industry would not be able to deliver steel in time and of suitable quality.⁴¹⁶

In a draft agreement made in April 1914, 283.13 million Kronen was the share of the Austrian and 135.71 million Kronen (two battleships, six destroyers and two monitors) the share of the Hungarian industry.⁴¹⁷ This meant only 32.4 % instead of 36.4 % of the orders for Hungary. Because a written formal agreement is missing from the files of the Kriegsarchiv, it is not known what the Navy exactly presented to the Hungarian negotiating party led by Finance Minister Teleszky. Doubtlessly, it should have been satisfactory for the Hungarians because on 20 May the Hungarian delegation voted in favor of the credit without any debate. On 28 May the Austrian delegation voted in favor of the credit as well, but only after a brief debate. The Austrian Social Democrat Karl Leuthner lamented that still more big, expensive battleships would be launched “into the ocean of the Austrian state debt.”⁴¹⁸

The Fate of the “*Improved Tegetthoff*” Class

As was mentioned previously, on 1 July 1914 the Navy approved the final design of the “*Improved Tegetthoff*” class. Unfortunately, there are a few unanswered questions about the fate of these battleships. The first problem is that in the files of the Kriegsarchiv in Vienna there is no sign of an official contract with either of the two shipyards.⁴¹⁹ Only the ten plus one spare 35 cm guns were ordered from the Škoda works.⁴²⁰ In the spring of 1914, the Navy made the following building schedule for the battleships VIII-XI:⁴²¹

VIII August 1914 – July 1917

IX August 1914 – August 1917

X January 1916 – January 1919

XI January 1916 – January 1919

However, in March 1914 the II Geschäftsgruppe questioned if the detailed plans of the 24,500 ton battleship would be completed in time.⁴²² This may mean that the schedule above was too optimistic. Whatever the Navy actually ordered one or more battleships or not, some preparatory works continued after the outbreak of the war. On 5 August, the joints of the barbette armor were tested by firing a 30.5 cm projectile on them,⁴²³ but probably nothing significant happened after this test. It is almost completely certain that neither of the first two battleships was laid down, because the average time in

Austria-Hungary between the order and the laying down of the keel of a battleship was 6 to 8 months and the battleships were cancelled a little more than four months after the outbreak of the war. Allegedly the Hungarian Finance Ministry tried to achieve the cancellation of the construction of the 24,500 ton battleships in October 1914. In December 1914, the 24,500 ton battleships were cancelled unofficially by the Navy,⁴²⁴ the official cancellation occurred at the 3 February 1915 meeting of the common Council of Ministers. Formally the battleships were not cancelled but their construction was postponed until the end of the war.

From the eleven 35 cm guns ordered two were certainly finished and a third may have been finished.⁴²⁵ The first gun, the Rohr Nr. 1 (Barrel No. 1) was tested at Pilsen in November 1914. These guns were designated as 35 cm M16 and were used on the Italian Front and on the Romanian Front. On the latter front a 35 cm gun along with two 42 cm howitzers provided artillery support for the Mackensen-Army which crossed the Danube at Shvistov in November 1916. The Rohr Nr. 1 after firing 122 rounds was sent back from the Italian Front to the Škoda where it was found that despite its damaged chamber the gun was still serviceable.⁴²⁶ The ultimate fate of these guns after the war is unknown.

Little more than half a year after the cancellation of the 24,500 ton battleships, the Navy began to work on new battleship and battlecruiser designs. The MTK presented a series of battlecruiser proposals of 30,000 – 32,000 tons armed with 9×35 cm, 6×38 cm or 4×42 cm guns. In addition, two battleship proposals were made between 1915 and 1917, a 30,000 ton ship armed with 8×38 cm guns and a 37,000 ton ship armed with 8×42 cm guns.⁴²⁷ These plans were completely unfeasible, in fact the Navy could not build ships larger than destroyers of 800 tons during the war, and the budget of the Navy declined after 1914. In sharp contrast to the ambitious battleship and battlecruiser proposals of the MTK, the sad reality was that the Navy had to keep in commission the tiny and obsolete coastal defense ships of the *Monarch* class which would have been replaced by the new battleships.

Finally, some remarks on the ship's names: there is a popular belief that the first 24,500 ton battleship to be laid down in the STT yard was to be named *Laudon*, while her sister which would have laid down in the Ganz and Co. Danubius was to

be named *Hunyadi*.⁴²⁸ In view of the name-giving protocol of the Austro-Hungarian Navy this seems to be a mere speculation. This protocol was regulated by the name-giving regulation of the Navy sanctioned by Franz Joseph on 5 May 1898. In the Austro-Hungarian Navy the name for a new ship usually was chosen a few months before her launch. When the scheduled time for the launch was nearing the Navy sent its name proposals to the Military Chancellery of the Emperor. The Emperor had

the right to approve or reject the name proposed, or to propose his own choice. From 1911 the Heir of the Throne Franz Ferdinand had a greater say in the name giving procedure, a change which caused headaches several times to the Marinekommandant,⁴²⁹ but the Emperor still had the final word. So, it can be concluded that the Navy never officially dealt with the names of the 24,500 ton battleships, because these battleships never reached the necessary phase of construction.

Technical data of the “*Improved Tegetthoff*” Class

Length on waterline: 172 m
 Overall length: 173.2 m
 Beam: 28.5 m
 Draught: 8.4 m

Displacements

With ammunition, without fuel and provisions:
 23,372 metric tons
 Normal or trial: 24,517 metric tons
 Full load, but without oil: 2,425 metric tons
 Full load: 26,460 metric tons

Weights

Hull: 7,093.8 tons (28.9 %)
 Equipment and provisions: 1,549.3 (6.3 %)
 Armament including turret shields: 3,344.1 tons
 (13.7 %)
 Ammunition: 1,131.1 tons (4.7 %)
 Machinery: 1,830 tons (7.5 %)
 Electric power plant and equipment: 335.5 tons
 (1.4 %)
 Vertical armor: 6,316.9 tons (25 %)
 Deck and torpedo protection: 1,814.3 tons (7.5 %)
 Fuel: 970 tons (4 %)
 Total including 132 tons margin: 24 517 metric tons

Machinery

9 coal firing Yarrow water tube boilers with oil spraying, 3,200 m² heat transfer surface area
 6 oil firing Yarrow water tube boilers, 2,600 m² heat transfer surface area
 (Danubius: 9+6 Babcock-Wilcox boilers)
 Boilers in 3 boiler rooms, two funnels
 2 sets of direct-drive Parsons-turbines (Danubius: AEG-turbines) on four shafts
 Turbines divided in three watertight spaces, main

condensers in the fourth
 Design power: 31,000 SHP
 Design speed: 21 knots
 Estimated speed: 21.42 – 21.58 knots⁴³⁰
 Range: 6,000 nautical miles
 Fuel: coal 1,425 tons, oil 1,035 tons

Electric power

6×250 KW turbine-driven DC dynamos
 2×150 KW turbine-driven DC dynamos
 2×150 KW motor-driven DC dynamos
 2× AC generators

Armor

(KC: Krupp cemented, K: Krupp non-cemented, SP: Spezialstahl)
 Belt: 310 mm KC, lower part tapered to 180 mm KC
 Upper belt: 150 mm KC
 Casemate: 150 mm KC
 Bow/stern: 140-130-110/200 mm KC
 Fore and aft armored bulkheads: 150 mm KC
 Conning tower upper/lower/roof:
 320/280/110 mm KC
 Upper part of the 15 cm control towers: 180 mm KC
 Barbettes fore/aft: 320-280-110/320-110 mm KC
 Funnels up to 2 m over upper deck: 30 mm K
 Upper deck/armor deck/torpedo bulkhead:
 36/36/36 mm SP
 Gun turrets face/side/inclined part/roof: 340/300-250/230 mm KC 80 mm SP

Armament

10×35 cm/45 K14 Škoda guns with sliding wedge breech
 Weight of fore gun turrets triple/twin: 849.2/613 tons

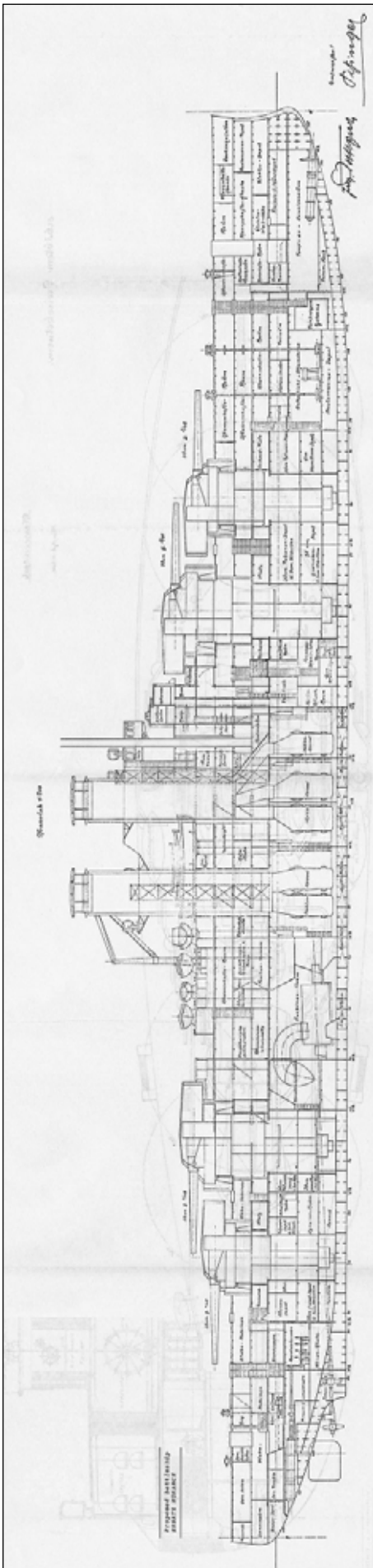

53 Longitudinal section of the "Improved Tegetthoff" class battleship

Weight of aft gun turrets triple/twin: 843/609 tons
 Weight of barrel with breech: 74 tons
 Elevation: $-4^{\circ}/+16^{\circ}$
 Elevation/train rate: 3° per sec/ 3° per sec
 Allowance for each guns: normal 76 + 12 practice
 Projectile's weight: 635 kg
 Muzzle velocity: 800 mps
 Range: N/A (Estimated range 21,000 m at $+16^{\circ}$)
 Armor penetration (hypothetic): 505 mm at
 8,000 m

14×15 cm/50 Škoda (Danubius: Magyar
 Ágyúgyár) guns with sliding wedge breech
 Weight of a gun with shield: 19.8 tons
 Elevation: $-6^{\circ}/+15^{\circ}$
 Weight of the ammunition: 80 kg
 Allowance for each gun: 225
 Projectile's weight: 45.5 kg
 Muzzle velocity: 880 mps
 Range: 15,000 m

20×9 cm/45 (8.8 cm) Škoda (Danubius: Magyar
 Ágyúgyár) guns with sliding wedge breech,
 12 of them for AA purposes
 Weight of a gun with mounting: 2,270 kg
 Weight of the ammunition: 18.5 kg
 Allowance for each gun: 400 (AA 550)
 Projectile's weight: 10.2 kg
 Muzzle velocity: 800 mps

6×53.3 cm Whitehead submerged torpedo tubes
 (1 bow, 1 stern, 2-2 broadsides)
 Allowance: 4-4 for fore & aft tubes, 6-6 for
 broadside tubes
 Torpedo's weight: 1,590 kg
 Overall length: 7.18 m
 Explosive charge: 180 kg

Fire control

1×5 m rangefinder on the top of the conning tower
 4×5 m rangefinders in the gun turrets
 2× rangefinders of unknown base length on the
 top of the 15 cm control positions
 12×110 cm searchlights

Boats (2×13 ton boats crane)

1×13 ton steam barge
 1×9 ton and 1×5 ton motor barges
 2×4.7 ton sailing barges
 4× cutters

1× rescue cutter
 2× jolly boats
 2× motor-gigs

4× small jolly boats
Complement
 38 officers, 16 NCO, 1,106 men

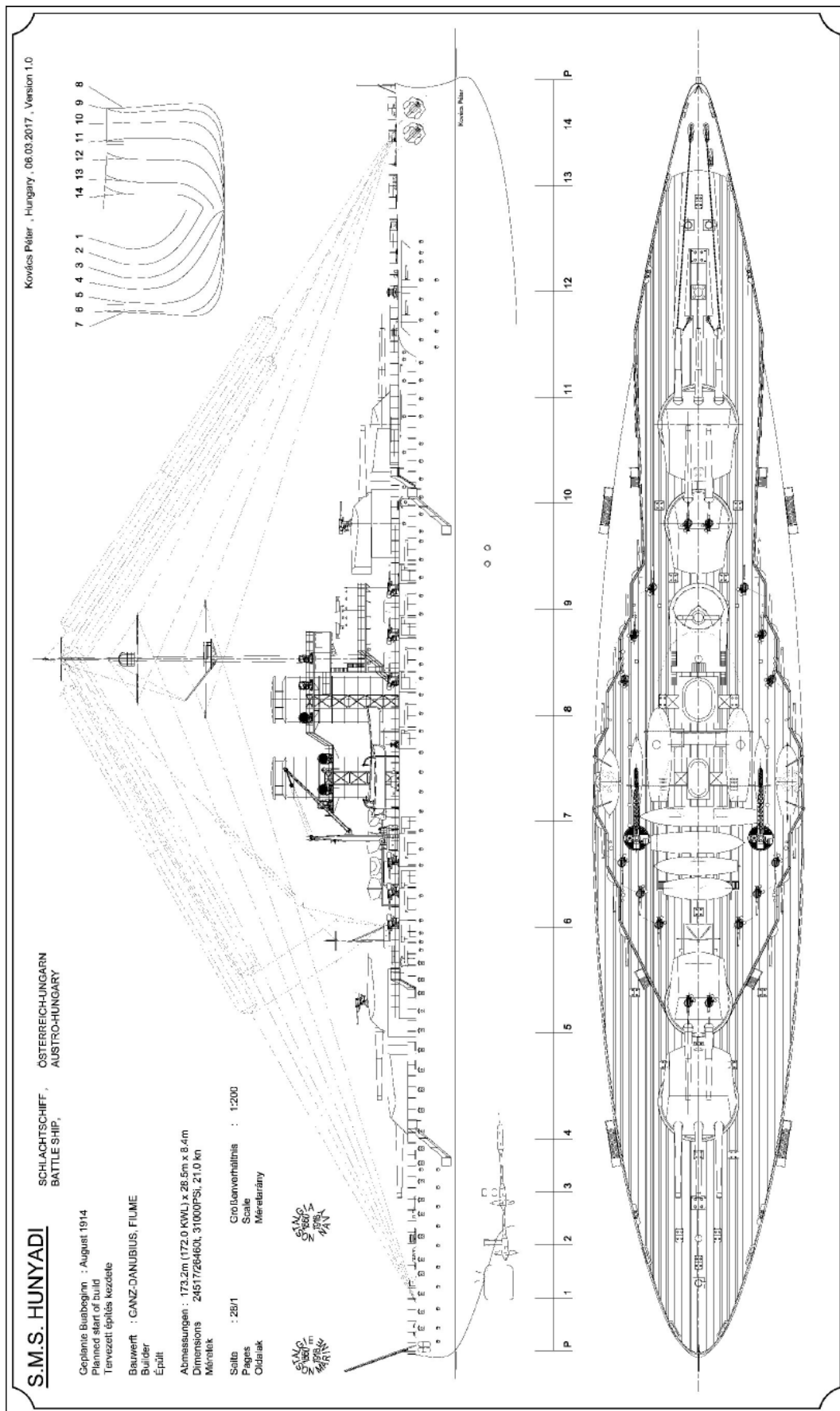

54 Model plans of the "Improved Tegetthoff" class battleships drawn by Péter Kovács (nostalgianavy.com)

AUSTRO-HUNGARIAN BATTLESHIPS IN PEACE AND WAR

THE SERVICE CAREER

OF THE RADETZKY AND TEGETTHOFF CLASSES

The last two battleship classes of the Austro-Hungarian Navy were destined to a relatively short active career like many other battleships of the time. They could not fulfill their main task for which they had been designed and built: to clash in a major naval battle with the enemy's battle fleet. Instead, they spent almost the entire war in the well-protected harbor of Pola. However, the Italian dreadnoughts, the main antagonists of the Austro-Hungarian battleships from May 1915, saw even less action. The *Tegetthoff* class was the unluckiest dreadnought class of the First World War: two of the four units sank in 1918 which is two-thirds of all dreadnoughts sunk during the war, excluding the ones destroyed in accidents. Post-war, the surviving five battleships were distributed between Italy and France but the 1922 naval disarmament treaty sealed their fate: four of them were scrapped and one was sunk as target ship.

La Belle Époque

The first unit of the *Radetzky* class, the *Erzherzog Franz Ferdinand* entered into service on 15 June 1910 as the new flagship of the Navy. The battleship was the flagship of the summer squadron flying the flag of Kontreadmiral Anton Haus. In the spring of 1911, the *Erzherzog Franz Ferdinand* made a tour with her sister *Radetzky* in the Levant. During this tour, German Emperor Wilhelm II visited the ship at Corfu. Between 22 and 25 August 1911, Franz Ferdinand personally led the summer maneuvers on board the *Erzherzog Franz Ferdinand*. The three units of the *Radetzky* class made a tour in the Levant in November 1912 during the First Balkan War.

The Dual Monarchy was represented at the Spithead Coronation Fleet Review of King George V in June 1911 by the battleship *Radetzky*. The battleship sailed from Pola on 5 June 1911 and arrived at Spithead on 19 June. Her commander, Linien-schiffskapitän Paul Fiedler travelled to London to

attend the Coronation on 22 June. At Spithead 165 British warships including 32 battleships and 19 foreign warships from 18 countries were gathered. The fleet review itself was on 24 June. King George V and Queen Mary inspected the parading vessels at Spithead on board the Royal yacht *Victoria and Albert*. The ships dressed overall and fired a twenty-one gun salute. The greatest spectacular of the review was the electric lighting of the participating vessels between 8:45 and 11 p.m. For this purpose, hundreds of light bulbs were placed on every ship.

On 6 October 1912, the Austro-Hungarian Monarchy entered into the dreadnought-era, first among the Mediterranean Powers with the commissioning of the new flagship of the fleet, the *Viribus Unitis*. The Austro-Hungarian Navy's first dreadnought held the honor of being the first battleship commissioned with triple gun turrets and also the dubious honor of being the most expensive warship ever built. The Dual Monarchy also became the first European power after Britain and Germany to have a dreadnought in active service.

On 16 February 1913, the white admiral's yacht *Lacroma* maneuvered alongside the battleship *Viribus Unitis*. Admiral Montecuccoli accompanied by the Flotteninspektor Vizeadmiral Haus went on the board of the fleet's flagship. This was the moment of Montecuccoli's farewell from the Navy. On the quarterdeck of the ship seventy-six officers, admirals and senior officers were gathered to say goodbye to the departing Marinekommandant. A group photo was made of the officers posing before the aft triple turrets, and Montecuccoli made a speech. Finally, he shook hands with the officers and returned to the *Lacroma* amidst the thundering of the saluting guns. A little later Admiral Julius von Ripper went on the board of the *Viribus Unitis* to bid farewell from the Navy too. Ripper and Haus were great rivals and, in the past, the two admirals had had many bitter conflicts. This was the moment of Haus's final victory. Ripper's leaving from the flagship marked the beginning of the "Haus era".⁴³¹

The Italian victory in the Italo-Turkish War in 1912 triggered a series of wars in the Balkans. During the First Balkan War in the spring of 1913 the interest of the Great Powers was engaged by the so called Scutari-crisis. The question where the city of Scutari should belong in the future, led to antagonism between Montenegro and her ally Serbia as well as with the European Great Powers. For the peaceful settlement of the problem a conference was convened in London. On 22 March 1913, the conference decreed that Scutari should belong to the independent nation of Albania in the future. On 29 March, an international naval demonstration was decided upon. Scutari was besieged by Montenegrin and Serbian troops from the end of October 1912. On 18 March 1913, Franz Joseph ordered the deployment the *Radetzky* class with two cruisers and some destroyers to Cattaro. On 2 April, this squadron under the flag of Kontreadmiral Maximilian Njegovan sailed to Antivari. It is worth mentioning that the commander of the *Zrínyi* was Linienschiffskapitän Alfred von Koudelka.⁴³²

The next day, Italian, French, British and German warships arrived before Antivari. British Vice-Admiral Sir Cecil Burney, as the highest ranking officer, held the command of the international squadron. Burney declared a naval block-

ade of the Montenegrin and Albanian coasts dating from 10 April. Serbia suspended the siege of Scutari but the Montenegrins continued on, and the Turkish defenders of the city surrendered on 23 April. After the capture of Scutari, King Nikola I of Montenegro was unwilling to evacuate the city. On 2 May, Austro-Hungarian common Foreign Minister Leopold Berchtold declared that the Monarchy would make independent steps to enforce the Great Powers decision. On 4 May, upon Russian and French intervention, King Nikola I decided to evacuate Scutari.⁴³³

The international naval demonstration proved to be a useful test bed for the new technologies used by the Austro-Hungarian Navy. Three French Donnet-Lèveque seaplanes were operated from the three battleships of the *Radetzky* class in late April, the first time in the history of the Imperial and Royal Navy.⁴³⁴ On 14 May, the blockade was lifted, but a great part of the international squadron remained in the mouth of the Bojana River. On 13 June, *Viribus Unitis* replaced the *Radetzky* class. The Monarchy's first dreadnought left the Albanian waters in late July and returned to Pola.

In July 1913, the independence of Albania was recognized by the Conference of London. Despite the decision of the Great Powers, Serbia contin-



55 The Austro-Hungarian fleet in 1913, *Viribus Unitis* ahead of the line followed by the three *Radetzky*s

The “French War”

ued the occupation of Northern Albania. In October 1913, the Dual Monarchy decided on a firm stand against Serbia over Albania. On 18 October, Austria-Hungary issued an ultimatum to Serbia on its own without consulting the Great Powers demanding that Serbian troops be withdrawn within eight days from the Northern Albanian territories. When the word of the ultimatum reached Pola, Haus was not very happy. He knew that it was a rather unfavorable moment for mobilizing the Navy, because two of the most modern battleships were under repair. The main steam pipe of the *Viribus Unitis* was under repair and the ship could not have been put in service again for two weeks. The other battleship temporarily unserviceable was the *Zrínyi* as the elevation gears of her gun turrets were under repair. It seemed that she would be ready again only after 10 November.⁴⁵⁵ Fortunately the Albanian Crisis passed, as on 25 October Serbian troops were withdrawn from Albania.

The last peacetime tour of the battleships was made between 30 March and 7 June 1914. The *Viribus Unitis*, *Tegetthoff* and *Zrínyi* visited Smyrna, Beirut, Alexandria and La Valetta. Between 4 and 18 May the British battlecruisers *Indomitable* and *Inflexible* visited Trieste, the Austro-Hungarian battleships returned this visit at La Valetta in Malta between 22 and 28 May. The reception of the Austro-Hungarian units was very cordial by the British. No one could foresee that two months later the two navies would be enemies.

In June 1914, Franz Ferdinand took a part of his last voyage on board the *Viribus Unitis*. On 24 June, he boarded the *Viribus Unitis* at Trieste and sailed to the mouth of the Narenta River. There he transferred to the yacht *Dalmat*, which steamed upstream to Metković, from where he travelled by train to Sarajevo. After the Sarajevo Assassination, the dead bodies of the Heir of the Throne and his consort were transported to Metković. In the mouth of the Narenta River the two coffins were transferred from the *Dalmat* to the *Viribus Unitis*. Upon hearing the news of the assassination, Haus raced to the Narenta aboard the yacht *Lacroma*, escorted by the *Tegetthoff*, the scout cruiser *Admiral Spaun* and several torpedo boats, arriving in time to witness the transfer of the coffins. Thereafter, the entire squadron steamed slowly to the North along the Dalmatian coasts with flags lowered to half-mast, reaching Trieste at the evening hours of 1 July.

The assassination of Franz Ferdinand was followed by a month of intense diplomatic activity called the July Crisis, which led to the general European war which had been predicted by many since the turn of the century. Unluckily, with the Sarajevo Assassination the strongest opponent of war in the Dual Monarchy was murdered. Franz Ferdinand in his last years gradually changed his belligerent views and realized that a great European war would cause the overthrow of such dynasties like the Habsburgs and Romanovs. In July among the most prominent leaders of the Dual Monarchy there were only a few, if any, who opposed a war with Serbia. The most potent possible opponents of a belligerent policy, the Heir of the Throne and the former Foreign Minister Alois Lexa von Aerenthal, were already dead. The others mostly viewed the Sarajevo Assassination as a divine opportunity to settle the Serbian question once for all, and a perfect *casus belli*, hoping that the European Powers were disgusted over the assassination enough to be sympathetic to any Austro-Hungarian action. They also underestimated the Russian threat. The only exception was the Hungarian Prime Minister István Tisza, who was realistic and who thought that the situation was unfavorable for a war against Serbia. On 7 July Tisza warned that any attack on Serbia would lead to an intervention by Russia and consequently to a world war. During the next two weeks Tisza was gradually persuaded, and he adopted the view that while the current situation was unfavorable for a war, the future situation would only be more unfavorable.

The Chief of the Austro-Hungarian General Staff Franz Conrad von Hötzendorf had a very important role during the July Crisis. As Admiral Haus remained in Pola, his deputy, Viceadmiral Karl Kailer von Kaltenfels represented the Navy in Vienna. When needed, Kailer joined Conrad in presenting the views of the armed forces in the common Council of Ministers, but no doubt Conrad played the lead role. On 7 July, Conrad was asked about the military balance and the Entente superiority. He answered that he did not know but he thought that the future changes would be not favorable for the Central Powers. He was also asked whether the armed forces of the Empire were prepared for a war or not. He answered yes they were prepared, while he knew well that the Army

was unprepared for a war with Russia, so Conrad misled the decision makers of the Dual Monarchy. But in this situation Conrad, who in the preceding years always had said that the external problems of the Empire could be solved only with a war, could say nothing else without losing face.

After the Austro-Hungarian ultimatum of 23 July to Serbia, Britain offered mediation, but this attempt failed. At this point even the German Emperor Wilhelm II changed his mind, but this resulted only in angering the German military leadership. The leaders of the Habsburg Empire marched the Dual Monarchy into a war with certain fatalism on 28 July which triggered a general European war within two weeks. The hopes for localizing the war ended within days. At the beginning of the war every belligerent thought that the war would not last long. Contrary to these hopes, the war lasted more than four years and cost more than ten million lives. The war led to the dissolution of the Austro-Hungarian Monarchy, and, as had been predicted by Franz Ferdinand, to the overthrow of the Romanovs, the Habsburgs and the Hohenzollerns.

As it was mentioned, Haus remained in Pola throughout the July Crisis. On 8 July, the third dreadnought, the *Prinz Eugen* was commissioned. The fourth member of the class, the *Szent István* was at Fiume in 72 percent complete. On the 31 July order of the Navy, she was towed to Pola. On the eve of the war, the most potent part of the Austro-Hungarian Navy was the First Battleship Squadron, commanded by Vizeadmiral Maximilian Njegovan, which was consisted of the three units of the *Tegetthoff* class (First Battleship Division) and of the three units of the *Radetzky* class (Second Battleship Division). The flagship of the whole operative fleet was the *Viribus Unitis*. Njegovan chose the *Tegetthoff* as his flagship. On 18 July, Haus received orders to mobilize the Navy for a Balkan war. On 22 July, he sent the three battleships of the *Radetzky* class to Cattaro, but within two weeks they were ordered back. On 24 July, Conrad sent to Haus the mobilization plans for the Adriatic forces and for the Danube Flotilla.⁴³⁶ After the declaration of war according to the preliminary plans Haus was promoted to Flottenkommandant, the commander of the active fleet. The general mobilizing for a war with Russia (Kriegsfall R) was ordered on 31 July.

On 28 July 1914, the Austro-Hungarian Monarchy declared war on Serbia. Thanks to the Naval Convention of the Triple Alliance of November 1913, in the first days of the Great War it seemed that the joint Austro-Hungarian-Italian fleet would conduct offensive operations against the French Navy. In the very first days of the war the Italian Navy made steps to fulfill the naval convention. On 29 July, the Chief of the Staff of the Italian Navy viceammiraglio Paolo Thaon di Revel ordered the 1st and the 2nd battleship squadrons to begin the preparations for mobilization.⁴³⁷ A few days later, on 2 August 1914 the Italian neutrality became official which torpedoed the prewar plans. The Naval Convention of the Triple Alliance, as did the Triple Alliance itself, ceased to exist on this day.

In mid-August 1914, the Austro-Hungarian Navy, the world's eighth largest navy, found itself standing alone against the world's fifth largest navy, the French, reinforced by British units. The only greater nightmare would be an enemy coalition of Britain, France, and the old rival Italy. This nightmare came true in May 1915, when Italy declared war on Austria-Hungary. No wonder, that Admiral Anton Haus wrote these lines in September 1914, explaining his position: "So long as the possibility exists that Italy will declare war against us, I consider my first duty to keep our fleet intact [...] for the decisive struggle against this, our most dangerous foe"⁴³⁸

The abovementioned strategic situation forced the Austro-Hungarian Navy to abandon all offensive plans, and the only possible choice was to defend their own coastline. The Austro-Hungarian Navy was bottled up in the Adriatic, but in exchange the eastern half of the Adriatic became practically an Austro-Hungarian lake. The French in 1914, the Italians in 1915, and the Americans in 1918 all harbored plans of amphibious operations against the Dalmatian coasts, but all these plans were rejected mainly due to the lack of available soldiers.

On the Adriatic, especially after the summer of 1915, the conflict evolved into a so-called "little war", fulfilling the 1880's prophecy of Archduke Albrecht.⁴³⁹ The Adriatic war was fought almost exclusively with submarines and light surface forces. It was soon found out that the confined waters of the Adriatic are unhealthy for large units due to the submarine menace. It is worth noting that even

the most modern battleships of the Mediterranean Powers lacked an effective torpedo protection system, and the navies were more or less aware of this fact. In addition, after the experiences of the battles of Dogger Bank and Jutland, seeing the vulnerability of the capital ships neither side was enthusiastic to risk its battle fleet in an open battle. This was especially true for Italy and Austria-Hungary.⁴⁴⁰ So from 1915, the Allied heavy units did not want to enter into the Adriatic while the Austro-Hungarian battleships were reluctant to leave their naval base at Pola. However, the threat that the seven modern Austro-Hungarian battleships posed as a “fleet in being” did tie up some Allied forces.

The battleships of the First Battleship Squadron left Pola for first time after the outbreak of the war on 7 August 1914 to assist the German Mittelmeerdivision. The Mittelmeerdivision, formed in 1912 was consisted of the battlecruiser *Goeben* and cruiser *Breslau*, its commander was Konteradmiral Wilhelm von Souchon. The battlecruiser spent the July Crisis in Pola, where her boilers were repaired. The *Goeben* left Pola and the *Breslau* left Durazzo as the Dual Monarchy declared war and the two ships steamed to Messina, only to confront the Italian declaration of neutrality. Souchon left Messina on 3 August for a raid on the Algerian coast. When he learned of the British declaration of war on Germany, he returned to Messina. The German ships were blockaded there by British units, and on 5 August Souchon sent a telegram to Pola asking Austro-Hungarian help. Despite the call for help being repeated from Berlin, Haus remained in Pola. Explaining his position, he pointed out that his fleet in Pola was much farther away from Messina than the French or the British forces.

Souchon managed to slip out from Messina on 6 August and headed for the Adriatic, followed by the pursuing British units. On the evening of 6 August, Berlin sent a telegram to the Austro-Hungarian Armee-Oberkommando (AOK) calling for Austro-Hungarian help again. This time the Germans issued a modified appeal, calling for the Austro-Hungarian fleet to come the latitude of Brindisi for a rendezvous with the Mittelmeerdivision. On the early morning of 7 August, Vienna informed Haus on the new German appeal. This time the Marinekommandant could not reject the German call for help. At 9 a.m. Haus left Pola with the three units of the *Tegetthoff* class, the

three units of the *Radetzky* class, escorted by the armored cruiser *Sankt Georg*, the cruiser *Admiral Spaun*, one *Tátra* class and five *Huszár* class destroyers and thirteen torpedo boats, in other words with the best and most modern units available. While the Dual Monarchy was still not at war with France and Britain, there was a state of tension on board the Austro-Hungarian ships, because everyone was afraid of a possible clash with the British or French forces. At 6:45 p.m. on 7 August, near the Cape Planka, Haus received the message of the German Admiralstab that Souchon’s move toward the Adriatic had been a diversion, and the German ships already had rounded Cape Matapan with their real destination being the Dardanelles. The Germans also added that by following Souchon’s lead and sailing for the Black Sea, the Austro-Hungarian Navy would perform its greatest service for the common cause. Haus was so angered by this suggestion that he immediately ordered his ships back to Pola.

Arriving back at Pola on 8 August Haus wrote a memorandum to the AOK, in which he pointed out that it, was practically impossible to reach the Black Sea without running into a superior British-French force. Furthermore, the Turkish ports lacked the basic facilities to support such a great fleet, which was aggravated by the fact at that time the Turks could not have supplied the ships there with coal, oil, ammunition and spare parts, because there was no direct connection between the Central Powers and Turkey. Haus argued also that if the Dual Monarchy’s Adriatic coastline were left virtually defenseless, the temptation for Italy would be great to join the Entente and declare war on Austria-Hungary. He wrote that the plan of deploying the Austro-Hungarian fleet to the Black Sea was not much more than a “*frivoles Va Banque-Spiel*” (frivolous gamble).⁴⁴¹ Conrad accepted Haus’s arguments, especially the logistical ones and the Italian threat. The frustrated Germans via their naval attaché in Vienna, Korvettenkapitän Freyberg, continued to try persuading Haus, but after 12 August when Britain and France finally declared war on the Monarchy, the Marinekommandant opposed the idea even more.⁴⁴²

The war on the Adriatic began for the Austro-Hungarian Navy when the tiny Kingdom of Montenegro declared war on the Dual Monarchy on 6 August. On 8 August, the old cruisers *Zenta*



56 *The French dreadnought Jean Bart (post-WWI photograph)*

and *Szigetvár* bombarded the Montenegrin port Antivari. Two days later the Austro-Hungarian Navy declared the naval blockade of the Montenegrin coasts. On 13 August 1914, the senior Entente commander in the Mediterranean, the French vice admiral Augustin Boué de Lapeyrère received word of the French and British declarations of war on Austria-Hungary. He was ordered to sail into the Adriatic immediately with all available French and British forces. Lapeyrère chose the tiny Austro-Hungarian blockading force off the Montenegrin coasts as his first target. Proceeding from the direction of Malta, Lapeyrère's vastly superior force consisted of fourteen battleships, including two dreadnoughts, succeeded in taking the small and obsolete cruiser *Zenta* and the destroyer *Ulan* by surprise on 16 August between Antivari and Cape Menders. Thanks to her greater speed the *Ulan* managed to escape back to Cattaro, but the much slower cruiser did not have a chance. Fregattenkapitän Paul Pachner, the commander of the *Zenta* chose the hopeless fight instead of surrender, and the tiny cruiser was sunk within forty minutes by the heavy shells of the battleships. The *Zenta* went down with one officer and 173 men from her crew of 324.⁴⁴³ Neither the French nor the British units of Lapeyrère's fleet attempted to rescue the survivors, who reached the Montenegrin coast af-

ter five hours of swimming. With the thundering of the guns of Lapeyrère's ships off Cape Menders on 16 August 1914 began the period of the Adriatic naval war which was colloquially called the "French War", and which lasted until Italy's declaration of war on the Austro-Hungarian Monarchy on 23 May 1915.

On 1 September, a dozen French battleships escorted by armored cruisers and lighter units sailed to Cattaro, where they bombarded the forts at the entrance of the Bocche di Cattaro. During that month the French made four sorties into the Adriatic, on 19 September reaching as far as Cape Planka. In October, the French made another three sorties. On 1 November, Lapeyrère made an attempt to take the Island of Lissa. At dawn of 2 November, a French destroyer entered the port, but after the Austro-Hungarian First Torpedo Flotilla led by the cruiser *Helgoland* arrived from Sebenico, the French left the island. Lapeyrère played the idea of sailing his fleet to Trieste, to provoke a clash with Haus's battleships but quickly dropped it, as he calculated that the losses would have been prohibitive. He also could not consider amphibious operations against the Austro-Hungarian coastline because the French Army under the pressure of the German Army was in no position to send soldiers to the Adriatic. The French presence at the

entrance of the Adriatic was weakened when the autumn stormy season arrived. The French ships could no longer be refueled on the open sea, and by October Lapeyrère had to devise a scheme for rotating his ships back and forth to Malta. Despite the weakening the French naval forces at the entrance of the Adriatic, partially thanks to the war psychosis, Haus continued to receive regularly false intelligence of an impending French offensive. The Marinekommandant refused to risk his larger units, and the modern battleships remained in Pola. The only exemption was the temporary deployment of the *Radetzky* to Cattaro.

Due to the critical situation on the Western Front the French had limited means to support their tiny ally, Montenegro. On 17 September, a large French squadron escorted a steamer to Antivari which carried a French detachment of two officers and 140 men with four 15 cm and four 12 cm naval guns. The guns were transported to the height Kuk of Mount Lovćen which towered over the Bocche on the Montenegrin side. The French battery was ready on 18 October and on the next day it began to bombard Teodo and the forts Vermoc and Gorazda. The French *charge d'affaires* in the Montenegrin capital, Cetinje, assured King Nikola I, that the Austro-Hungarian fortresses in the Bocche soon would be destroyed. The French gunfire caused some damages to the fortresses so the Flottenkommando (Fleet Command) decided for reinforcing the Fifth Battle Division (the *Monarch* class coast defense ships) in Cattaro, and sent there the *Radetzky*. The battleship arrived on 22 October, and on the next day she began to bombard with her 30.5 cm and 24 cm guns the French battery from 11 kilometers with the help of an observation balloon reeled from her poop deck. The *Radetzky* fired twenty-three 30.5 cm and fifty-six 24 cm HE projectiles over a five day period.⁴⁴⁴ By 27 October, the *Radetzky* had destroyed two of the French guns, while the others were removed from the battery. Capitaine de frégate Grellier, the commander of the detachment, in his report suggested to waste no more French lives and handed over the remaining guns to the Montenegrins, because he thought that it would be impossible to take the Bocche. In November the detachment was withdrawn from Montenegro and its guns were left behind as it had been proposed by Grellier. The *Radetzky* remained until 16 December in Cattaro. After this success the

Austro-Hungarian squadron in the Bocche earned some respect from the French.

On 21 December 1914, the Austro-Hungarian Navy achieved its first great success against the French. The submarine U XII⁴⁴⁵ commanded by Linienschiffsleutnant Egon Lerch launched two torpedoes at the French dreadnought *Jean Bart* at the Saseno Island near the Albanian port Valona. The French were lucky because one of the torpedoes missed and the other hit the bow causing no fatal damage. The *Jean Bart* with 1,400 tons of water in the bow managed to reach Malta, where she was docked and repaired. She was recommissioned in early April 1915. While the *Jean Bart* was lucky, it was a near-catastrophe because the French dreadnoughts lacked the effective torpedo protection system, as the Austro-Hungarians and the Italians did. Lapeyrère realized how risky was deploying battleships in the Southern Adriatic due to the threat of a submarine attack. The French never again sent battleships into the Adriatic. The French decision further increased the chances of that the Adriatic would not be the future scene of great clashes between battle fleets.

In January 1915, Paolo Thaon di Revel, Chief of the Staff of the Italian Navy revised his September plans for a possible war with Austria-Hungary. The lessons of the first months of the war were learned; Thaon di Revel was well aware of the threat what the mines and submarines were posed. He and his Italian colleagues still desired an engagement between the battle fleets thus revenging Lissa, but he insisted to use the Italian battleships only against the Austro-Hungarian battle fleet and never risking them to fall victim of mines or torpedoes during less important operations. Thaon di Revel recommended maintaining a group of warships in Brindisi superior to the Austro-Hungarian forces in Cattaro ready to attack and cut them off whenever they came out. The guiding principle of his strategy was that the light forces should hold the burden of the operations and the large units should be preserved for the decisive clash with the enemy's battle fleet.⁴⁴⁶ After Italy's entry to the war these ideas and principles characterized more or less the Italian conduct of the naval war on the Adriatic. There was, however, a major problem which remained unresolved until the end of the war: how to lure out the Austro-Hungarian battle fleet from Pola.

Turkey was very important for the Germans and when the ill-fated Dardanelles campaign began in February 1915, they urged Haus to help the Turks. The Dardanelles project was the brainchild of Winston Churchill, then First Lord of the Admiralty. Frustrated by the stalemate on the Western Front, he advocated an attack on the “soft underbelly” of the enemy. After considering Schleswig or the Adriatic finally the Dardanelles were chosen. The unsuccessful attempt to storm the Turkish straits led only to the fall of Churchill as First Lord of the Admiralty and the reactivated Sir John Fisher as First Sea Lord. Through mid-March, before the failure of the British became obvious, the Germans put a great pressure on Haus to do something. Among other demands the Germans suggested an attack on the French forces at the mouth of the Adriatic. Even after the Turkish position stabilized some politicians of the Dual Monarchy and the Germans continued urging Haus to attack the French. Count István Burián, common Foreign Minister argued that a naval victory over the French would deter Italy from entering the war. Desperate to secure the Italian neutrality, Burián did not realize the unreality of such a demand and the high chances that an action against the French fleet would rather push Italy towards the Entente.⁴⁴⁷ The German embassy in Vienna also tried to put pressure on Haus, employing even Baron Max von Beck, former prime minister of Austria as an emissary.

On 31 March, Haus wrote a lengthy letter called as the Haus Memorandum to Baron Beck in which he explained and defended his policy.⁴⁴⁸ Haus repeated his earlier argument about the limited achievements of the French in the Adriatic. He pointed out that the French were content with blocking the entrance of the Adriatic, and since neither the French nor the Austro-Hungarian fleet had a goal important enough to risk their destruction in a battle, that strategy of patient waiting is the sole rational one. Haus wrote: “To attack a superior fleet under these circumstances, when one does not know where to find it and how large their superiority is an unreasonable demand”. He complained: “It is difficult to make clear to many men that in many cases not to do anything is the only correct thing.” He pointed out that actions like Coronel, Falkland Islands and Heligoland had resulted in the defeat of the materially weaker squadron. Haus concluded that if one can draw lessons

from this, it is certainly not that the Austro-Hungarian fleet, which was much weaker, should increase the activity of its battleships. The old Emperor and Archduke Friedrich, titular head of the AOK agreed with Haus’s arguments.⁴⁴⁹

On the night of 26–27 April, the Austro-Hungarian Navy achieved its greatest success against the French. During the diplomatic negotiations between the Triple Entente and Italy, Lapeyrère extended to farther north the course of the French cruiser patrols. This decision proved to be disastrous. The Austro-Hungarian submarine U 5 commanded by the future submarine ace Linienschiffleutnant Georg Ritter von Trapp torpedoed and sank the French armored cruiser *Léon Gambetta* off Cape Santa Maria di Leuca on the Ionian Sea. The cruiser went down in only nine minutes with 574 hands. The sinking of the *Léon Gambetta* marked the end of the “French War” as Lapeyrère withdrew all his heavier units south to Cephalonia. Due to this decision and other circumstances the French blockade of the mouth of the Adriatic practically ended in May 1915. In the remainder of the war the French sent against the Austro-Hungarian Navy only submarines and destroyers.

A couple of hours before the U 5 sank the *Léon Gambetta* on 26 April the Treaty of London between the Triple Entente and Italy was signed. Signing the treaty Italy committed itself to declare war on Austria-Hungary and Germany within one month. On 23 May a new phase of the Adriatic naval war has begun: the so called “Italian War”.

The Eve of the “Italian War”

The Triple Alliance was never popular among the population of Italy. The country’s archenemy was the Dual Monarchy, the mysterious and menacing “Regno del Nord” of Dino Buzzati.⁴⁵⁰ Most of the disputed territories claimed by the Italians, fueled by *Italia irredenta*, were part of the Habsburg Empire, so not surprisingly the Central Powers could offer little during the diplomatic bargaining that took place after the outbreak of the war. Over the winter of 1914–1915, Italian Foreign Minister Sydney Sonnino negotiated with both sides in an effort to secure the best deal for Italy in exchange for its entering in the war. Germany pressured the Monarchy to appease the Italians, but this was a very

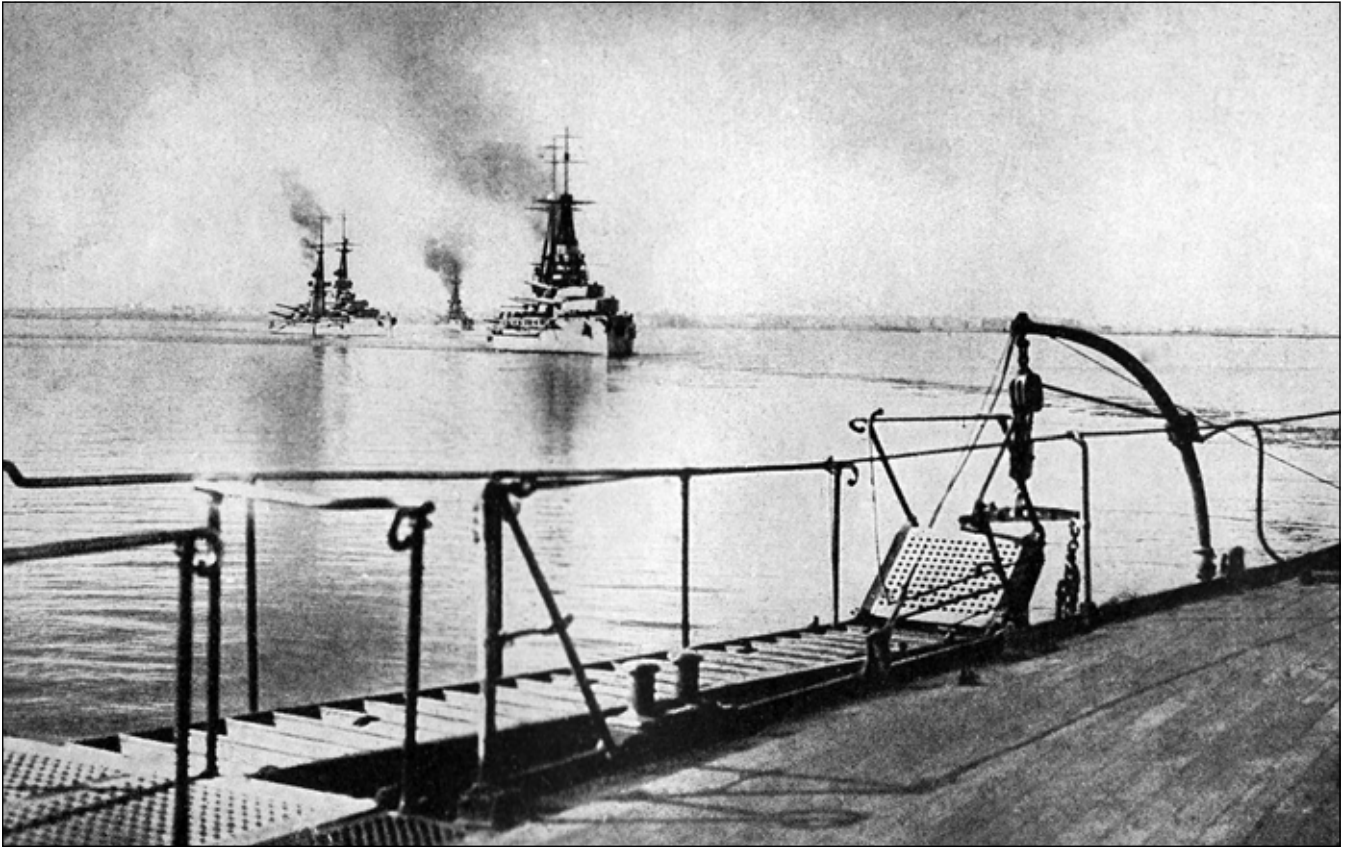

57 Italian dreadnoughts

hard if not impossible task. Italy asked a price too high even for its neutrality: Trentino and Trieste. In March 1915, Austro-Hungarian common Foreign Minister Burián offered the Italian speaking part of Tyrol, but it was too little, too late. To Italians, the intervention of Italy to the First World War is sometimes referred to as *Quarta guerra d'indipendenza italiana* – The Fourth Italian War of Independence, reflecting the view that this war was the final act in the unification of the nation.

The Entente was in the position to offer a much more attractive deal to Italy, not to mention that they did not have to sacrifice their own territories. Only the question of Dalmatia complicated matters, because Russia strongly supported Serbia's claim for a substantial part of Dalmatia. In the Treaty of London signed on 26 April 1915, the Triple Entente promised to Italy territories which had beside the Italians also an ethnic German and Slav population. A part of Tyrol, Trieste and the entire Istrian Peninsula, a part of Northern Dalmatia including Zara and Sebenico and many of the islands along the Dalmatian coast would go to Italy in a postwar settlement. The Entente confirmed also the possession of Valona and a sphere

of influence in Albania. The fulfillment of all the promises would have rendered the Adriatic de facto an Italian *Mare Nostrum*.

The third article of the Treaty of London provided for the naval cooperation. "The French and British fleets shall render active and permanent assistance to Italy until such time as the Austro-Hungarian fleet shall have been destroyed or until peace shall have been concluded. A naval convention shall be immediately be concluded to this effect between France, Great Britain and Italy." The naval discussions were started on 2 May in Paris and after some hard bargaining on 10 May a formal naval convention was concluded. The convention called for the establishment of the so called First Allied Fleet and the Second Allied Fleet. After Italy's entry into the war, bearing the burden of operating against the Austro-Hungarian fleet was primarily the task of the First Allied Fleet. This fleet, based at Brindisi and at Taranto, was composed of the most modern Italian units, a contingent of a dozen French destroyers and six submarines and a British detachment of four old standard battleships and four small cruisers. The Second Allied Fleet was de facto Lapeyrère's force. While the

commander in chief of the Anglo-French forces in the Mediterranean was Lapeyrère, in the Adriatic Sea all the French and British commanders were subordinated to the Italian commander in chief. The commander in chief of the Italian Navy between 1914 and 1917 was Prince Luigi Amedeo Duca degli Abruzzi, a polar explorer and the cousin of King Vittorio Emanuele III.

Oddly enough, the three parties had not any specific operational plan when Italy declared war on Austria-Hungary. This, and other factors, as the far from cordial Franco-Italian relationship or the low opinion of the British on the Italian Navy at least questioned the efficiency of the future naval cooperation between the three powers. In May 1915 the Italian Navy had five completed dreadnoughts (*Dante Alighieri*, *Giulio Cesare*, *Leonardo da Vinci*, *Conte di Cavour* and *Caio Duilio*) and one still under construction, completed in March 1916 (*Andrea Doria*). This was an equal, or slightly superior force compared to the three *Radetzky*s and the three completed *Tegetthoff*s, while in older battleships, armored cruisers, cruisers and smaller units the First Allied Fleet had at least a twofold superiority over the Austro-Hungarian fleet. The Italian dreadnoughts were based at Taranto, while the four *Regina Elena* class and the two *Regina Margherita* class standard battleships, the newest Italian ships of this type were deployed at Brindisi. Abruzzi planned to keep his dreadnoughts outside the Adriatic in the first phase of the war. Nevertheless, he as many others in the Italian fleet dreamed of the revenge for Lissa, but Abruzzi together with Thaon di Revel was cautious enough. Only after the southern Adriatic was cleaned of Austro-Hungarian light surface units and submarines would leave the Italian battle fleet Taranto for the Southern Adriatic in hope that Haus and the Austro-Hungarian fleet could be lured out from Pola. But the advantageous moment never came and the Italian dreadnoughts did not enter into the Adriatic until October 1918.

Political and military leaders of the Austro-Hungarian Monarchy were well aware of the diplomatic activity between the Triple Entente and Italy. On 27 April, the AOK warned Haus that Italy might launch an attack without declaring war. But Haus was well aware of the situation even without this warning as he regularly read the reports of the naval intelligence service as well as the Italian

press. In accordance with the Treaty of London, on 4 May Italy officially left the Triple Alliance, so it became evident that the hostilities would soon begin between the Monarchy and Italy. Korvettenkapitän Albrecht Freiherr von Freyberg, the German naval attaché in Vienna and a great enemy of Haus since August 1914, urged the Austro-Hungarian Navy to strike first, even before a formal declaration of war. The Marinesektion told him that no attack could be launched without the authorization of the Emperor.⁴⁵¹

Haus had plans from August 1914 for a strike against Ancona and the eastern coastline of Italy to be executed immediately after the Italian declaration of war. From 19 May the cruisers *Helgoland* and *Admiral Spaun* and several destroyers patrolled the routes between Gargano, Lagosta and Pelagosa, watching the lower Adriatic to prevent any unpleasant surprise from the south. The waters before Ancona were searched twice by torpedo boats and submarines to make sure that the Italians had not laid mines there. When word of the Italian mobilization ordered on 22 May reached Pola, the fleet was ready for an action against Ancona. It seemed probable that Italy would declare war on Austria-Hungary on the next day, so on 23 May the fleet in Pola stood ready to put to sea after darkness fell.⁴⁵²

The Bombardment of Ancona

At 4:15 a.m. on 24 May Peter von Moritz, the Austro-Hungarian Consul General in Ancona was tipped out of bed by two violent detonations which were followed by thundering of guns. At 5 a.m. an Italian police officer angrily told him: "Your nation is bombarding an open city!" Later he learned from another police officer that seventeen Austro-Hungarian warships had appeared before the city and had bombarded it.⁴⁵³

The Bombardment of Ancona on 24 May was the largest action of the Austro-Hungarian Navy during the war. This was also the only successful large fleet action against the enemy, and the only occasion – not counting the failed rendezvous with the *Goeben* in August 1914 – when the units of the *Tegetthoff* and the *Radetzky* classes put to sea together against the enemy. The detailed orders for the strike against Ancona and the Italian coastline were issued on 9 May.⁴⁵⁴ Haus as Flottenkomman-

dant wanted to lead his fleet personally against Italy. As flagship he chose the oldest battleship which was to participate in the action, the *Habsburg*. The reason behind this decision was that Haus did not intend to risk a dreadnought if he would run on a mine leading his fleet. The First Battleship Squadron was commanded by Vizeadmiral Maximilian Njegovan.

The word of the Italian declaration of war reached Pola at 4 p.m. The news of the declaration of war was allegedly welcomed by a spontaneous cheering of the sailors. The fleet raised steam, and the first reconnaissance groups left Pola at 7 p.m. At 7:30 p.m. Haus went on the board of the *Habsburg*. The battleships left the harbor between 8 and 8:30 p.m. En route to Ancona the *Radetzky* was detached from the fleet at 1:07 a.m. on 24 May and the *Zrínyi* at 1:45 a.m. The target of the *Radetzky* was the mouth of the Potenza River, while the *Zrínyi* sailed to Senigallia. After 3 a.m. the fleet led by Haus arrived near Ancona. Between 3:12 and 3:47 the torpedo boat groups which searched the waters before the city reported one after another that the southern and the northern route were free of mines. At 4:06 a.m. the Second Battleship Squadron composed of the three units of the *Habsburg* and the three units of the *Erzherzog Karl* classes heading towards Ancona at a speed of 6 knots on the southern route opened fire. At 4:10 a.m. Haus sent a radio telegram to every ship in which he ordered not to fire on churches.⁴⁵⁵

At 4:05 a.m. Haus ordered Njegovan to come closer. Njegovan with his four battleships, the three dreadnoughts and the *Erzherzog Franz Ferdinand* made a turn and followed the Second Battleship Squadron. At 4:34 a.m. Njegovan's flagship, the *Tegetthoff* opened fire from a distance of 6,400 m. In the next few minutes the other three battleships joined her. The last of them, the *Erzherzog Franz Ferdinand*, opened fire at 4:48 a.m. Njegovan's ships ceased fire between 4:55 and 5 a.m. Anyone imagining that during this 20–25 minutes period the heavy guns of the four battleships were thundering continuously, firing broadside after broadside is seriously mistaken. In fact, the ammunition was used economically and the commanders protected well the interests of the Treasury, expending only a few of the expensive,⁴⁵⁶ heavy shells. The *Tegetthoff* fired twelve, the *Prinz Eugen* five and *Viribus Unitis* an unknown number of 30.5 cm HE projectiles,

while the *Erzherzog Franz Ferdinand* did not fire a single one and only three 24 cm shots. At 5:06 a.m. on Haus's order, Njegovan's battleships left the scene and accelerating to full speed joined the Second Battleship Squadron. At this time appeared in the air the Italian airship M.2 *Città di Ferrara*⁴⁵⁷ at which the *Tegetthoff* fired six rounds from her 7 cm AA guns without any effect.⁴⁵⁸ It is interesting to note that the Italian airships were nicknamed in the Austro-Hungarian Navy as "Staniolhund" (tin foil dog).⁴⁵⁹

After she was detached from the fleet, the *Radetzky* escorted by two torpedo boats sailed to a point eight nautical miles off the mouth of the Potenza River. The battleship stopped there and the torpedo boats searched her intended course for mines. During this operation the contact sweep broke, so it had to be replaced which caused some delay. At 4:20 a.m. the *Radetzky* reached the point where she turned on the course which led to the firing position. At 4:37 a.m. from a distance of 3,000 m she opened fire on the stone bridge over the Potenza River. The large dust clouds caused by the hits covered the whole mouth of the river, so it had to cease the fire for a while. When the dust cloud dissipated the *Radetzky* opened fire again, this time on the railway bridge. The battleship ceased fire at 4:50 a.m. and left the mouth of the Potenza River. During this action she fired five 30.5 cm, five 24 cm and seventeen 10 cm HE projectiles. One of the 30.5 cm projectiles exploded in the air 600 m from the ship.⁴⁶⁰ The *Radetzky* united with the fleet after 5:15 a.m.⁴⁶¹

The *Zrínyi* arrived near Senigallia sometimes before 3:30 a.m. Between 3:35 and 4:00 a.m. the two escorting torpedo boats searched the waters before the city. At 4:03 a.m. the battleship opened fire from a distance of 3,400 m. Due to the shallow water a torpedo boat sailed slowly ahead of the battleship constantly sounding the depth. *Zrínyi*'s guns fired on the port, the water tower, the railway bridge and the railway station. When they fired on the station, a train coming from the north was spotted, so it was also destroyed with the 24 cm and 10 cm guns. At 4:38 a.m. the *Zrínyi* ceased fire and turned on the course leading to the meeting point with the fleet. Linienschiffskapitän Daublebsky did not mention in his report the number of the projectiles fired. At 4:45 a.m. they spotted the Italian airship *Città di Ferrara* coming from the direction of



58 *The Bombardment of Ancona on 24 May 1915*

Fano. From the poop deck of the *Zrínyi* a few dozen sailors commanded by two officers opened fire on the airship with machine guns and rifles, and the commander of the ship, Linienschiffskapitän Maximilian Daublebsky ordered an increase in speed and to zigzag. The *Città di Ferrara* dropped five bombs, all of which missed the battleship by 50-100 meters. The airship had started a new attack on the *Zrínyi* when two Austro-Hungarian flying boats appeared. The Italians fled, increasing their altitude. As it was mentioned, fifteen minutes later the airship encountered Njegovan's squadron. The *Zrínyi* united with the fleet at 5:25 a.m.⁴⁶²

Other Austro-Hungarian units bombarded different locations near Ancona on the eastern coastline of Italy. The armored cruiser *Sankt Georg* bombarded Rimini. The scout cruiser *Admiral Spaun* bombarded the signal station at Cretaccio Island, while the destroyer *Streiter* attacked the signal station at Torre di Mileto. The scout cruiser *Novara*, commanded by Linienschiffskapitän Miklós Horthy, the later Flottenkommandant, escorted by three light crafts entered the Corsini Channel and bombarded Porto Corsini. The *Novara* was the only ship which suffered damages and casualties during the operation, when she was hit by an Italian shore battery. Six men were killed and ten wounded from

her crew of 325.⁴⁶³ A squadron composed of the scout cruiser *Helgoland* and four destroyers ran into the Italian destroyer *Turbine* and sank her. The destroyers *Tátra* and *Csepel* shelled Manfredonia. The fleet arrived back to Pola after an uneventful voyage around 11 a.m.

In Ancona heavy damage was inflicted by the guns of the battleships. The port facilities, the railway station, the old barracks which served as military hospital at that time and several private houses were damaged. Despite the definite order of Haus, the Ancona Cathedral, the Duomo San Ciriaco, was damaged. Different sources put the number of the deaths between 63 and 70 in Ancona alone. The majority of the victims lost their lives when the military hospital was hit. In contrast to the first Austro-Hungarian reports and despite their hopes the Italian railway line which ran along the eastern coastline was only lightly damaged. It is worth noting that it was always a very hard task to evaluate the damage done in land targets from the board of a ship. Citterich, the Austro-Hungarian Vice-consul in Brindisi on the day of the bombardment with his wife travelled incognito along the railway line from Brindisi to Jesi through Ancona and Rimini. The train could cross all the railway bridges which were shelled a few hours before and

the damaged railway facilities were under repair or even already repaired.⁴⁶⁴

The Italian Press wrote about the “barbaric enemy” after the Bombardment of Ancona. Later it turned out that while the Italian government declared Ancona an open city in 1914, the government itself did not proclaim this declaration.

It’s worth a closer examination the report on the action of 24 May of the commander of the *Viribus Unitis*, Linienschiffskapitän Edmund Grassberger in the context of the alleged ventilation problem and lack of oxygen in the triple turrets described one year later. The *Viribus Unitis* which followed the *Tegetthoff* and was the second ship in Njegovan’s line, opened fire at 4:38 a.m. and ceased fire at 5:00 a.m. During this 22 minutes period she fired an unknown number of 30.5 cm and 15 cm projectiles. Grassberger, who was notorious for his manner and his long, pamphlet-like reports in which he criticized every defect, real or imagined; this time wrote a very short report, the shortest of all the battleship commanders. In his report he did not mention any problem with the turret ventilation.⁴⁶⁵ It is inconceivable that such a serious problem would not have been reported, especially because a less important problem with one of the *Tegetthoff*’s 30.5 guns was reported, and this report was repeated in Njegovan’s report.⁴⁶⁶

After the action of 24 May, during the summer of 1915 the Austro-Hungarian Navy shelled Italian land targets on a few occasions, but in these operations only cruisers or smaller units participated. The largest battleships of the Navy remained in the well-defended naval base of Pola for (almost) the rest of the war. The *Radetzky*s until November 1918 left Pola only for gunnery practice in the Fasana Channel. The same was true for the *Tegetthoffs* until 8 June 1918. On 8 and 9 June 1918, the four dreadnoughts of the Monarchy left Pola for participating in the ill-fated “Operation Korfu” which ended prematurely due to the sinking of the *Szent István*.

The Italian War: The Long Stalemate

After its entry to the war Italy’s activity on the Adriatic intensified in June 1915. The Italians succeeded in occupying the tiny and remote Pelagosa Island on 11 July. The four newest and largest

Italian armored cruisers were deployed to Venice to support the Army’s operations and also to attack and destroy enemy naval forces in the Northern Adriatic. It was soon demonstrated how dangerous the confined waters of the Adriatic were for larger units lacking the proper torpedo protection system. On 7 July, the German submarine UB 14 under Austro-Hungarian flag (Germany and Italy were not yet officially at war) torpedoed and sank the Italian armored cruiser *Amalfi*. The Italian Navy had a plan for an attack on Ragusa, and this led to their second major loss: the armored cruiser *Garibaldi* en route from Brindisi to Ragusa was torpedoed and sunk by the Austro-Hungarian submarine U 4 commanded by Linienschiffleutnant Rudolf Singule on 18 July. The Italian Navy planned also the occupation the Island Lagosta, but this was rejected. On 17 August, Austro-Hungarian cruisers and destroyers appeared at Pelagosa and shelled the Italian positions. The Italians decided for giving up the tiny, barren island and on the next day evacuated Pelagosa.

Owing to the serious losses of the Italian Navy in the first months of the war, the reputation of the Regia Marina was ravaged in the eyes of the Italian public. After losing two armored cruisers, in September a serious accident occurred: the battleship *Benedetto Brin* blew up in Brindisi with a great loss of lives.⁴⁶⁷ By the end of the summer of 1915, the war in the Adriatic was a stalemate and this stalemate lasted practically until October 1918. In October 1915, Thaon di Revel resigned from the position of Chief of Staff and took command of the naval base of Venice. He returned to the top in February 1917 and became the Commander in Chief of the mobilized naval forces when the Commander in Chief of the Navy, Prince Luigi Amedeo was dismissed.

The French liaison officer, capitaine de vaisseau René Daveluy, provided a perfect analysis of the situation by the end of August: “From these facts one can draw the following conclusion: submarines prohibit large warships from keeping to the sea, each party scratched their heads to ‘do something’ but one has not found any other thing to do except small operations which have no real significance and are, above all, intended to give the illusion one is acting. But, as one cannot fire indefinitely on the same bridge, the same station, the same railways, the same lighthouses and the same semaphores, it seems

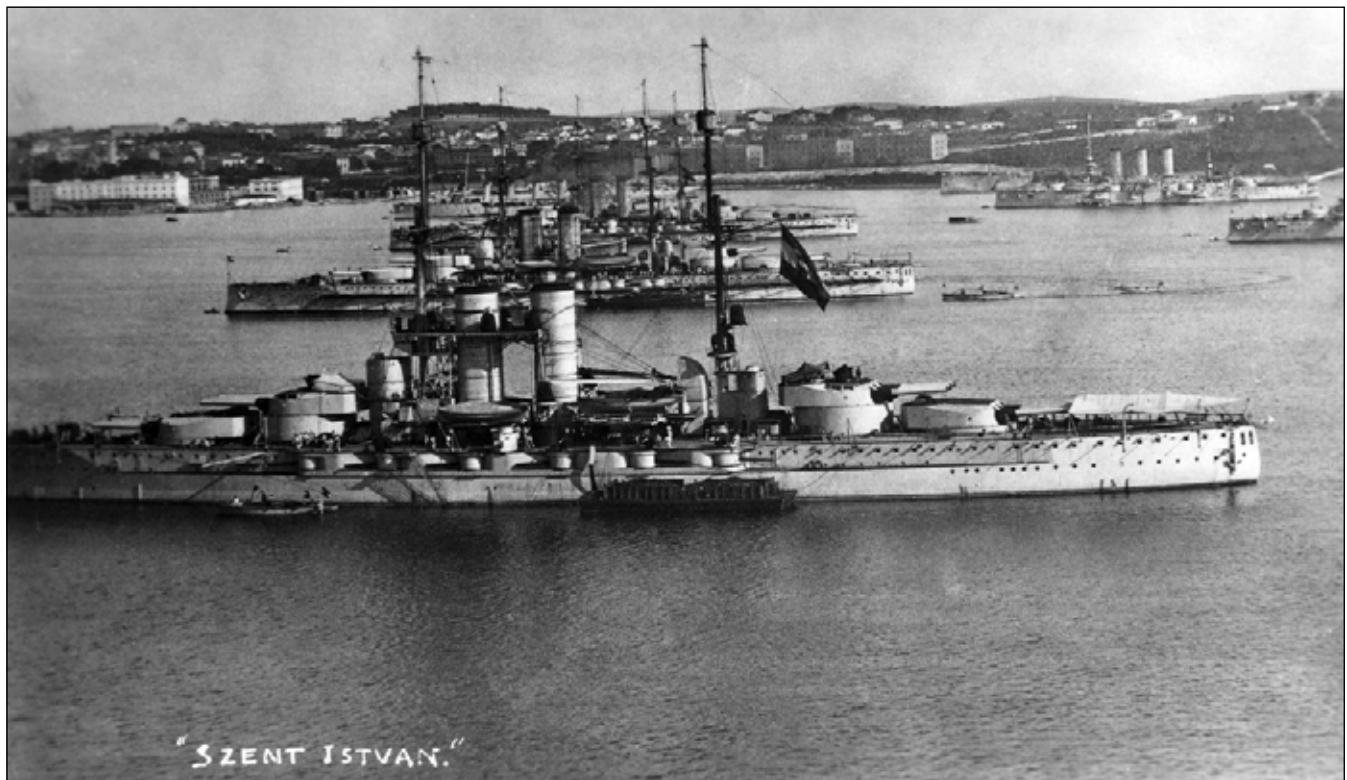

59 *Austro-Hungarian dreadnoughts at Pola in 1916, Szent István in the foreground*

clear that now the Italians and the Austrians are at the end of their resources; after having wanted to do ‘something’ no one longer knows ‘what to do.’”⁴⁶⁸

Linienschiffskapitän Erich Heyssler who was the Chief of Staff of the Cruiser Flotilla (Kreuzer-Flottille) between 1914 and 1917 had similar thoughts: “The military situation on the Adriatic was like that it was not suitable for larger scale, promising actions. There were times in 1915 when our relative inactivity, compared to the performance of the Army, was weighing on our minds. We were always thinking ‘we must do something; we have to perform something again’. [...] Some of our attacks on the Italian coasts originated only from our desire ‘to do something’. Real strategic success was therefore not associated with them.”⁴⁶⁹

Behind the inactivity of the large Austro-Hungarian units stood also other factors beside the above described situation. The most important of these factors was the fuel shortage. The Austro-Hungarian Navy before the war relied entirely on imports of coal. More than 90 percent of the Navy’s coal was imported from Britain. Domestic coal was considered unsuitable for fuel due its high sulfur content.⁴⁷⁰ British coal was of the best quality and the cheapest so the boilers and grates of the Navy’s ships were optimized for burning British coal. In

1913-1914, on the initiation of the new Marinekommandant, Anton Haus the Navy purchased much higher quantity of coal than in the preceding years. Thanks to Haus, the Navy had stockpiled nearly 330,000 tons of coal before the outbreak of the war. After the outbreak of the war, it became impossible purchasing more coal from Britain and from the USA; therefore the Austro-Hungarian Navy had to rely on the prewar stocks and on the strictly limited shipments of German coal. As the battle fleet consumed 1,000 tons of coal per hour on the open sea, sending the large units frequently into missions would have resulted in fast depletion of the stock of high quality coal.⁴⁷¹

The pet project of the Allied Powers especially of the British on the Adriatic was the Otranto barrage from 1915. The father and inventor of this barrage was Winston Churchill, the First Lord of the Admiralty. Its purpose was to prevent the German and Austro-Hungarian submarines entering from the Adriatic to the Mediterranean. As Italy lacked the ships and the financial means, the British took over the barrage and its command. Despite the great efforts the barrage was ineffective. The idea of closing the narrow entrance of the Adriatic with nets towed by drifter fishing boats did not work in reality. The destroyers and other Allied

vessels tied up in guarding the barrage were badly missed from convoy escort duties in the worst days of the submarine warfare. The greatest and most famous battle of the Adriatic theatre, the Battle of the Otranto Straits in May 1917 evolved from an Austro-Hungarian raid on this barrage.

The death of the old Emperor Franz Joseph in November 1916 and the accession to the throne of Emperor Karl brought important changes in the military and civil leadership of the Dual Monarchy. The new emperor presumably was planning to remove the old and ailing Haus from his position, but something other was occurred. Karl met the German Emperor Wilhelm II at Schloss Pless in January 1917 discussing the unrestricted submarine warfare. Haus accompanied Karl, and on the way back to Pola get a cold in his unheated railway car. On 8 February, the Marinekommandant died of pneumonia aboard his flagship, the *Viribus Unitis*. At the time of Haus's death now existed a plan to reorganize the Navy's command, including the separation of the administrative command from the operational command of the fleet. Vizedmiral Maximilian Njegovan, commander of the First Battle Squadron was appointed to Flottenkommandant and was promoted to full Admiral, but the post of Marinekommandant remained vacant. Vizeadmiral Karl Kailer was appointed to Chef der Marinesektion. This system was very short lived: Kailer died in April 1917 and Njegovan was promoted to Marinekommandant and Chef der Marinesektion. With these promotions, the pre-1917 system of command was restored, which had been established by Tegetthoff back in 1868.⁴⁷² In his one year period of command Njegovan continued the cautious policy of Haus, but he lacked the undoubted authority of his predecessor.

In the greater part of 1917, things went relatively well for the Austro-Hungarian Navy. It caused more losses to the enemy than suffered itself. The small Austro-Hungarian submarine force doubled during 1917 and successfully joined the unrestricted submarine warfare being waged at that time. It is worth mentioning though, that this submarine force played a secondary role in the submarine war on the Mediterranean, while the German submarines operating from Austro-Hungarian ports had the heaviest burden of it in this theatre. On 15 May 1917, took place the most famous naval engagement of the First World War on the Adriatic,

the Battle of the Otranto Straits, a great success for the Austro-Hungarian Navy. The three *Helgoland* class cruisers led by Linienschiffskapitän Miklós Horthy made a raid on the Otranto barrage, sinking fourteen drifters of forty-seven. On the way back to Cattaro a battle evolved between the three cruisers and the joint British-Italian-French forces sailed from Brindisi to intercept Horthy's ships. The heavier artillery of the Allied cruisers crippled Horthy's flagship, the *Novara*. The Italian commander, contraammiraglio Alfredo Acton broke off the pursuit seeing the smokes of Austro-Hungarian heavy units closing from Cattaro on the horizon, which enabled to escape the three Austro-Hungarian cruisers. On this day the Allies lost two destroyers, one merchant steamer and fourteen drifters while the Austro-Hungarians lost not a single ship.⁴⁷³

Fortune turned against the Austro-Hungarian Navy on 10 December 1917. On this night an Italian MAS (motor torpedo boat) commanded by Luigi Rizzo sneaked into the Gulf of Trieste, and torpedoed and sank the old coastal defense ship *Wien*. This event marked the beginning of the decline of the Austro-Hungarian Navy. Njegovan sank into depression, as naval historian Paul G. Halpern wrote: "[Njegovan] who was reputed to be interested solely in regular meals and rest, always refused anything proposed to him and seemed to have given up."⁴⁷⁴

The first signs of a breakdown of discipline were the demonstrations in Pola in the summer and fall of 1917. Discontent over shortages of food was the main cause of these demonstrations. Order and discipline was restored with little difficulty, and Njegovan wisely chose not to enforce harsh punishments.⁴⁷⁵ The discontent of sailors after three and half years of war culminated in the Cattaro mutiny in February 1918. No doubt, there were political motives behind the mutiny, but its main causes were war weariness, shortage of food, and the enormous gap between the life of the sailors and their officers. This gap under the commanding officer of the forces in the Bocche di Cattaro, Kontreadmiral Alexander Hansa had grown too wide on board the idle, older ships. The mutiny began at noon on 1 February on Hansa's flagship. On 3 February, after the arrival of the three battleships of the Third Battle Division (*Erzherzog Karl* class) from Pola, the mutineers surrendered. From the mutinous crews 392 men were arrested, four of

them were sentenced to death and executed. Order and discipline – at least on the surface – were restored. In Hungary up to this day there exists a strong popular belief that Horthy was sent to Cattaro with the Third Battle Division as a special emissary to suppress the mutiny and the executions were ordered by him. This false story was invented by the Communist regime in the 1950s to blacken Horthy, the former Regent of Hungary.⁴⁷⁶

Emperor Karl appointed Admiral Archduke Karl Stephan to a special emissary making investigations of the causes of the mutiny and to recommend changes for the future.⁴⁷⁷ One of the results of Cattaro's and Karl Stephan's report was the change of the command system of the Navy. The Marinekommandant and Flottenkommandant, Admiral Njegovan was forced to retire. It was offered to him to formally retire on his own request which he accepted. Emperor Karl resumed the command of the Navy personally. He was represented by Vizeadmiral Karl von Keil, who was appointed to "Admiral zur Disposition der allerhöchsten Oberbefehls" (Admiral at the disposition of the High Command). Karl wanted a young, energetic admiral as the commander of the fleet, so he promoted Linienschiffskapitän Miklós Horthy, the "Hero of the Battle of the Otranto Straits" to Kontreadmiral and appointed him Flottenkommandant, the commander of the active fleet on 27 February 1918.⁴⁷⁸ Horthy's appointment caused great discontent among the senior admirals. Vizeadmiral Franz von Holub was appointed to the Chef der Marinesektion in Vienna. As Walter Wagner wrote in his book, the 1918 February reorganization of the command of the Navy, the separation of the administrative command from the operational command had an ad hoc nature and its main goal was to placate the senior admirals angry over the appointment of Horthy.⁴⁷⁹ Horthy as the commander of the active fleet was subordinated directly to the Emperor and had to ask the permission of Karl for all major fleet actions.

The Sinking of the *Szent István*

In the first months of his tenure Horthy executed a reorganization program, which included the transfer of officers and men, and the decommissioning many older warships. After these changes the ac-

tive fleet counted only the seven most modern battleships in Pola (*Tegetthoff* class, *Radetzky* class), and three older battleships in Cattaro (*Erzherzog Karl* class). In March 1918, the American Mediterranean commander, Vice Admiral William Sims proposed an offensive action in the Adriatic to cut off the communication line between Pola and Cattaro, and to bottle up the German and Austro-Hungarian submarines. He planned an assault on Cattaro itself. The lack of available Allied soldiers, especially after the beginning of the German offensive on the Western Front (21 March) sealed the fate of these ambitious plans and all operations were cancelled.⁴⁸⁰

After the exit of Russia from the war the Dual Monarchy reached an agreement with Germany to undertake a new offensive against Italy, which was later called as the Second Battle of the Piave River. The start of the offensive was scheduled for end of May, so it would to be launched at roughly the same time with the second German assault on the Chemin des Dames in France. Later the date of the offensive was postponed several times; finally the date of 15 June was fixed. The two army group commanders on the Italian front, Franz Conrad von Hötzendorf, the former Chief of Staff and Svetozar Boroević von Bojna, who had a dislike for each other, could not agree about the location of the attack. The Emperor and the new Chief of Staff, Arthur Arz von Straußenburg were unable to decide either, which led to a plan of an all-out frontal attack employing the Army all along the front. For such an offensive against the much better organized Italian defense system compared to the one in the previous year the Austro-Hungarian Army simply did not have enough strength. The matter was complicated by the lack of equipment, materiel and food. As it was predictable the offensive launched on 15 June collapsed within days due to strong Italian resistance and lack of supplies. By 23 June, the Italians recaptured all territories lost and the battle was over. The failure of the offensive marked the beginning of the end of the Austro-Hungarian Army and the multiethnic Empire itself.

The Navy had its own plan for an attack in the first half of June. The target of the attack, the so called "Operation Korfu" was the Otranto Barrage again, but this time not only with light forces but with supporting battleships as well. Unfortunately, our knowledge is scarce about the genesis



60 Miklós Horthy, nagybányai, the last Flottenkommandant.
The photograph was taken after his promotion to Vizeadmiral
on 1 November 1918

and the real scopes of the plan as about its possible connections with the Army's offensive of 15 June. Perhaps future researches will reveal more information about the decision making process preceding "Operation Korfu". Until the emergence of new documents, researchers could mostly rely on different memoirs. It should be noted that the historical value of these memoirs is often limited.

In his memoirs Horthy writes about the genesis of the plan: "It seemed to me that the best way to restore discipline in the Navy would be to put ships into action, a view that I knew was shared by my colleagues of the German Navy. The men who had not yet heard a shot fired in anger must be shaken out of their lethargy.

I decided therefore to take the fleet out and once again try to break the blockade of Otranto. The whole fleet was to be engaged in this operation, for it was clearly certain that, after the experience of May 15th 1917, the enemy would throw in battle cruisers at least in an attempt to intercept and destroy our returning warships. I hoped that our fleet would be able to surround and destroy them."⁴⁸¹

The English historian Owen Rutter in his authorized biography of Horthy published in 1939 writes: "Having received permission from Admiral Keil he began to make plans and took only twelve officers into his confidence. Even so it was always supposed that there may have been some leakage of information. The Austro-Hungarian fleet had no *Tintenschiff*, as the German navy had at Wilhelmshaven, in which secret operations were worked out. Horthy's plans were made in his own cabin in the *Viribus Unitis*, which had the only table large enough to take the charts. During the day the usual routine had to be carried out, so that the conferences took place at night, and even if no unauthorized person overheard a word of it, it was obvious that an action was being planned.

The scheme as finally evolved was for a surprise attack on the Straits by cruisers and destroyers, with supporting battleships to cover their withdrawal by engaging any enemy ships which might come out from Valona and Brindisi. All vessels were to be in position for the attack by dawn on 11 June."⁴⁸²

It should be understood that these memoirs or authorized biographies have little historical value, as their main purpose is to paint a favorable picture of their authors or subjects. Relying only on these could be very misleading. As it was mentioned the main problem is the lack of official documents. During the past hundred years generations of researchers could not find official documents related to the planning of "Operation Korfu" in the Kriegsarchiv in Vienna. Probably a great part of the most important documents made in the Flottenkommando at Pola never reached the Marinesektion at Vienna. In the last days of October 1918, many documents were burned in Pola. The remaining documents fell into Italian hands and were transported to Italy. As it was mentioned Horthy as Flottenkommandant had to ask the permission of the Emperor to a major fleet action. On 27 May 1918 Horthy had a private audience with the Emperor.⁴⁸³ Most probably the Flottenkommandant at this audience presented his plan to the Emperor, but there is no information what was said at this meeting.

The plan of the "Operation Korfu" comprised a raid on the Otranto Barrage and on the Italian naval and air base of Otranto by cruisers, destroyers and torpedo boats. German and Austro-Hungarian submarines would be sent to Brindisi and

Valona to ambush the Allied warships sailing out to intercept the Austro-Hungarian light forces. Seaplanes from Cattaro would provide air support. The great novelty of the plan was the employment of the four dreadnoughts of the *Tegetthoff* class and the three *Erzherzog Karl* class battleships to set a trap for the intercepting Allied warships. The Assault Group "A" which consisted of the cruisers *Novara*, *Helgoland* and four *Tátra* class destroyers were to raid the barrage itself and sink as many drifters as possible. The Assault Group "B" consisted of the two slower cruisers, *Admiral Spaun* and *Saida* escorted by four 250 ton torpedo boats would bombard the Otranto air and naval base. The seven battleships with seven small escort groups were to be distributed one by one on the Southern Adriatic along the possible courses of the intercepting Allied squadrons. These were designated as Support Groups "A" through "G".

Group "A" *Viribus Unitis*, destroyers *Balaton*, *Orjen* and four 250 ton torpedo boats

Group "B" *Prinz Eugen*, destroyers *Dukla*, *Uzsok* and four 250 ton torpedo boats

Group "C" *Erzherzog Ferdinand Max*, destroyer *Turul* and five 200 ton torpedo boats

Group "D" *Erzherzog Karl*, destroyers *Huszár*, *Pandur*, two 250 ton and one 200 ton torpedo boats

Group "E" *Erzherzog Friedrich*, destroyers *Csikós*, *Uskoke* and three 200 ton torpedo boats

Group "F" *Tegetthoff*, destroyer *Velebit*, one 250 ton and three 200 ton torpedo boats

Group "G" *Szent István* and five 250 ton torpedo boats

"Operation Korfu" was scheduled for 8-11 June when the nights were moonless. The raid on the Otranto Barrage itself was planned for dawn on 11 June.

In the meantime, especially from the end of 1917, the Allies considerably reinforced the Otranto Barrage. The barrage was widened and for patrolling purposes the Allies had 40 destroyers, 20 submarines, 124 drifters, 36 British submarine chasers and an American submarine chaser flotilla. In Brindisi and Valona British and Italian cruisers were stationed. The largest Allied warship in Brindisi was the Italian standard battleship *Roma*. With her two 30.5 cm and twelve 20.3 cm guns she was no match for an Austro-Hungarian dreadnought. The Italian dreadnoughts were far away in Taranto, too far to interfere if the Austro-Hungarian battleships succeeded to reach unnoticed their positions at dawn of 11 June.

The crucial factor of the success of the "Operation Korfu" was surprise. The above described secrecy during working up of the plans for the offensive was essential. Naturally, it was impossible to entirely conceal the preparations for the large fleet action in such a city as Pola which was crawling with Italian spies. From the first days of June reservists and seamen on leave were called in, the four dreadnoughts were inspected, ammunition and fuel were loaded. These were clear signs for the popula-

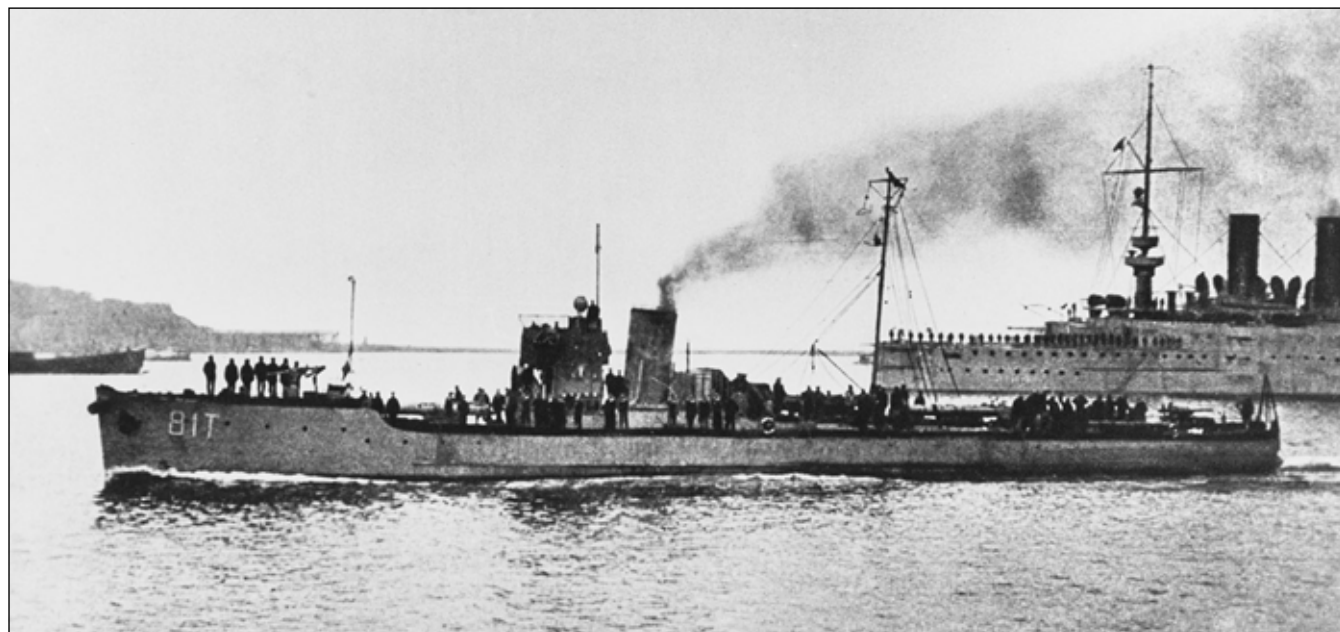

61 Austro-Hungarian 250 ton torpedo boat, six of such boats escorted the *Szent István* and the *Tegetthoff*

tion of the city that something would happen. Despite this from the available Austro-Hungarian and Italian documents it can be deduced that there was no serious leakage of information. The Navy succeeded in keeping secret the plan of the offensive and the destination of the four dreadnoughts. The Italians realized on 10 June only after the sinking of the *Szent István* that something major was occurring. It is important to emphasize this because many treachery theories exist up to day. We have not enough space here to discuss them in detail,⁴⁸⁴ but all these theories state that the encounter of the *Szent István* and the *Tegetthoff* with the two Italian motor boats led by Luigi Rizzo was not by accident.

While the cruisers and the *Erzherzog Karl* class battleships were already at Cattaro, the four *Tegetthoffs* had to slip out from Pola days before the raid to reach the Southern Adriatic. According to Horthy's plan the battleships had to leave the naval base in two groups on 8 and on 9 June respectively. Horthy, who led the operation personally, left Pola on the evening of 8 June with the *Viribus Unitis* and the *Prinz Eugen* escorted by four *Tátra* class destroyers and eight 250 ton torpedo boats. Aboard the Flottenkommandant's flagship, the *Viribus Unitis* there was also a group of journalists, presumably to chronicle the coming victory. Among the journalists was the famous Egon Erwin Kisch who styled himself as "Der rasende Reporter" (Raging Reporter). Kisch later wrote about the operation and his experiences on the *Viribus Unitis* but his account is full of lies.⁴⁸⁵ The two dreadnoughts and their escort sailed to the little port of Tajer which they reached on the early morning of 9 June. From Tajer Horthy's group sailed to Slano on the night of 9/10 June.

On 9 June, at 2 p.m. the two dreadnoughts of the second group, the *Szent István* and the *Tegetthoff* began to raise steam. The commander of the group was the commander of the *Szent István*, Linienschiffskapitän Heinrich Seitz. Because Horthy's group had taken on the preceding day all the modern destroyers and the majority of the available 250 ton torpedo boats, the escort of the second group was consisted only of the old 400 ton destroyer *Velebit* and six 250 ton torpedo boats (numbers 76, 77, 78, 79, 81 and 87). The commander of the escort was the commander of the *Velebit*, Korvettenkapitän Stanisław Witkowski. Witkowski had been the gunnery officer of the cruiser *No-*

vara in the Battle of the Otranto Straits in May 1917. Both Maschinebetriebsleiter 1. Klasse Karl Mohl, one of the survivors of the sinking of the *Szent István* in his memoirs and the board of inquiry which investigated the sinking considered this escort insufficient for two dreadnoughts.⁴⁸⁶

According to the plans the second group would have left Pola at 10 p.m. on 9 June, but the ships left the harbor somewhere between 10:40 and 11 p.m. This late start was the fault of Linienschiffskapitän Charles Masjon, Chief of Staff of Seitz who failed to give the order to open the harbor boom in time.⁴⁸⁷ Seitz hoped that he could make up the lost time and after leaving the Bay of Pola increased the speed of his squadron to 16 knots. At 00:20 a.m. on 10 June, the Maschinebetriebsleiter of the *Szent István* reported to Seitz that the bearings of the turbines were overheating. Consequently, the speed of the *Szent István* thus that of the entire squadron had to be reduced to 12 knots. Due to the inexperience of the stokers, large black clouds and sometimes sparks were emitted from the funnels of both battleships which dangerously increased the chances of detection. After half an hour of cooling it became possible to slowly increase the speed of the ship. Around 3:30 a.m. near the Premuda Island northwest of Zara the *Szent István* reached the speed of 14 knots when she was hit by two Italian torpedoes.⁴⁸⁸

At 5 p.m. on June 9, the Italian motorboats MAS 15 and MAS 21 left Ancona in the tow of the torpedo boats 18 OS and 15 OS. The commander of the action was the commander of the MAS 15, the now legendary capitano di corvetta Luigi Rizzo, the hero of the sinking of the *Wien* and the "La beffa di Buccari".⁴⁸⁹ This was another random event in the chain of events which led to the sinking of the *Szent István*: this sortie originally had been planned for 7 June but due to engine problems it had to postpone to 9 June. It was a routine mission; the two motorboats had been sweeping mines during the night in the Selve Channel near to the Dalmatian coasts. They were now sailing back to rendezvous with the torpedo boats when at 3:15 a.m. Rizzo spotted large clouds of smoke on the starboard quarter at a distance of six nautical miles. First, he thought that smaller units were coming from Lussin to intercept them. He ordered a 180 degrees turn with the intention to attack the Austro-Hungarian ships. As the two motor boats

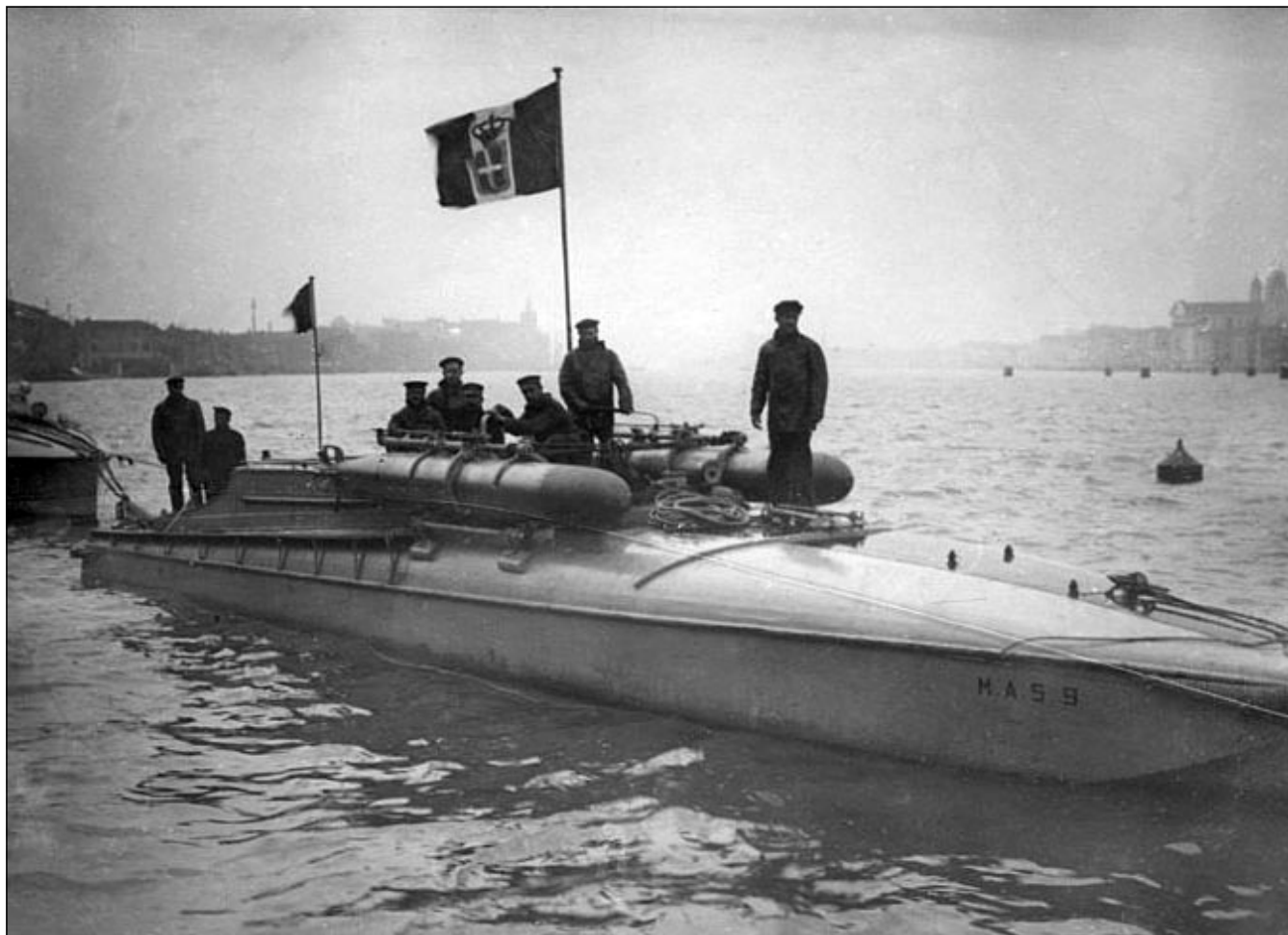

62 Italian MAS motor torpedo boats

slowly approached Rizzo realized that two large units and their escort were coming. Rizzo managed to slip unnoticed between two escorting torpedo boats and launched the two torpedoes of the MAS 15 from a distance of 300 meters which hit the *Szent István*. Ironically, the two 45 cm torpedoes were manufactured in Fiume, the same city where the *Szent István* was built.⁴⁹⁰ The MAS 21 commanded by guardiamarina Giuseppe Aonzo attacked the *Tegetthoff*. Aonzo reported that one of the torpedoes hit the battleship while the other due to the malfunction of the launcher missed her. In fact, both of the torpedoes of the MAS 21 missed the *Tegetthoff* or the one which hit her failed to explode. The torpedo boat 76 gave a chase to the MAS 15 which dropped two depth charges which forced the torpedo boat to turn away. The two MAS boats managed to escape unharmed and returned to Ancona at 7 a.m. on 10 June.⁴⁹¹

Around 3:30 a.m. Linienschiffsleutnant Jenő Szentgyörgyi Szégner checked the positions of the escorts with his pair of binoculars from the bridge

of the *Szent István* when torpedo boat 76 suddenly turned to starboard by 45 degrees because her crew had spotted the two motor boats. The torpedo boat tried to overrun the motor boats and made a blast on her horn when one of the motor boats launched her torpedoes. On the *Szent István* the blast on the horn was not heard but from the bridge two coming bubble trails were spotted. They began to maneuver but it was too late, the two torpedoes hit the starboard side of the *Szent István*.⁴⁹² The first torpedo hit the aft boiler room near the transversal watertight bulkhead which separated the two boiler rooms. The second torpedo hit the starboard fore turbine room near the transversal bulkhead which separated it from the aft boiler room.⁴⁹³ The first victims of the two explosions were the crews of the nearby 15 cm and 7 cm magazines. The death yells from the 7 cm magazines could be heard through the open hatches of the ammunition hoists on the Oberdeck.⁴⁹⁴

As Tirpitz had prophesized nine years before, the torpedo protection system designed in an

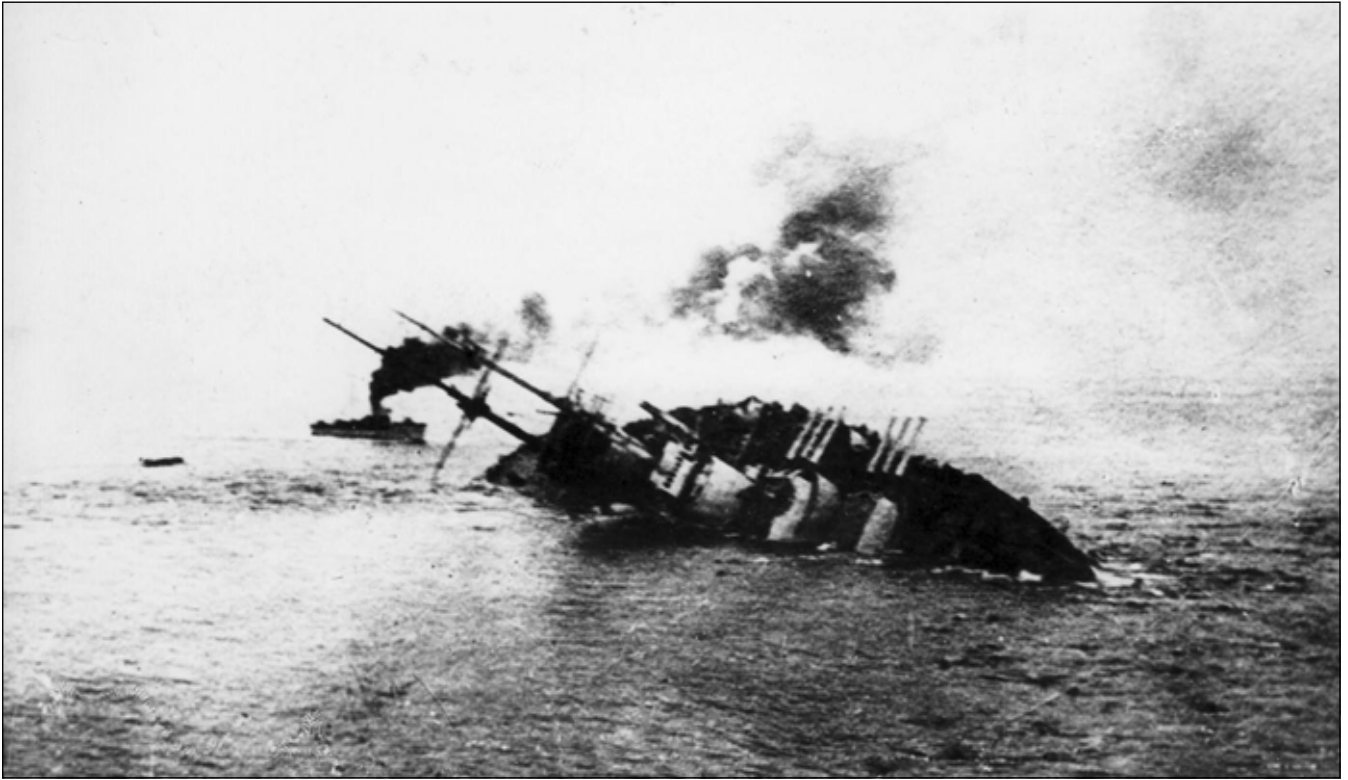

63 Szent István sinking on 10 June 1918 near the Premuda Island

armchair without taking into account the German data, failed to protect the ship. The explosions pierced the 50 mm thick torpedo bulkhead which was only 2.5 m from the side shell plating and the thin external bulkheads of the coal bunkers and 15 and 7 cm magazines which were behind the torpedo bulkhead separated by a vault space of 0.2 – 0.9 m. The explosions could not pierce the longitudinal watertight bulkhead which separated the coal bunkers and the magazines from the boiler and turbine rooms and only damaged it otherwise; the water would have flooded immediately into the aft boiler room and the starboard fore turbine room. Water began to flood the aft boiler room from the direction of the bilge keel. The pumps could not keep up with the flooding and within twenty minutes the water level was near to the level of the boiler grates. The fire in the boilers was raked out and the steam was blown off through the safety valves to prevent a boiler explosion. Twenty minutes after the torpedo hits all men left the aft boiler room.⁴⁹⁵ While the fore boiler room was not directly hit a water jet through an ash ejector began to flood into this boiler room too,⁴⁹⁶ but here the pumps could keep up with the flooding. When the aft boiler room was abandoned all the pumps were switched to pump out the water from the fore boiler room.⁴⁹⁷ Inter-

estingly, about the effects of the second torpedo hit there is little information in the official reports and memoirs. Only the report of the board of inquiry mentions that through a corridor the water found its way from one of the flooded 15 cm magazines to the starboard turbine rooms.⁴⁹⁸

The water flooded the ship not only through the pierced torpedo bulkhead. The other important element of the torpedo protection system, the outer part of the armored deck which closed the system from above failed to contain the flooding. Hungarian diving expeditions discovered that the outer edge of the of the sloped part of the armored deck above the holes made by the torpedo hits separated from the side shell plating leaving a gap of few meters long and at least half meter wide. As it was mentioned, the outer part of the sloped part of the armored deck was only 18 mm thick instead of 48 mm which proved to be a fatal error. This thin edge could not withstand the force of the explosion and water could flood compartments above the armored deck. The thin 6.5 mm thick outer longitudinal bulkhead of the coal bunkers above the armored deck which run immediately above the torpedo bulkhead was pierced or separated from the deformed armored deck. Water flooded these coal bunkers which increased the list of the ship.

The list of the ship soon reached 10 degrees. Counterflooding succeeded in reducing the list to 7 degrees. The turbines were stopped in order to try closing the holes with collision mats. The *Szent István* carried three mats but they did not know that these 4×4 meters mats were considerably smaller than the holes made by the torpedoes. The two holes were approximately 5×7 meters.⁴⁹⁹ When the ship stopped and the list was reduced to 7 degrees seemingly the crew succeeded in fitting one of the mats over the aft hole. It was a temporary success only, because one of the ropes broke.⁵⁰⁰ Further attempts to fit another collision mat over the hole were unsuccessful due to the list and the ropes became stuck on the bilge keel. The gun turrets were trained to port by 90 degrees and the ready projectiles (eighteen per turret) were thrown off from the turret rears in the hope that the turrets which were nose heavy without the ready projectiles stowed in the rear of the gunhouses would counterbalance somewhat the list.⁵⁰¹ Allegedly the turrets were trained by hand which lasted fifteen minutes. It is known from official files that the gun turrets of the *Szent István* had been fitted with small crude oil engines coupled to the emergency hand training gears in 1917,⁵⁰² so it is possible that these engines were used to train the turrets.

Despite the counterflooding and other measures the list of the ship began slowly to increase. As time went on and the list increased it worsened the situation in the fore boiler room. The transversal bulkhead which separated the two boiler rooms under the pressure of the water which flooded the aft boiler room began to bulge, rivet heads popped out and water began to leak through the joints. The men tried to caulk these leaking joints with hammocks and other materials. As the water level rose in the fore boiler room and the list increased, stokers in the two starboard boilers had to rake out the fire. Later in the two center boilers the stokers had to rake out also the fire. The two port boilers continued to produce steam until the very end. In the meantime, the electric lighting went out and stokers worked at the light of electric torches because the emergency lighting was insufficient. The men working in the fore boiler room were led by Karl Mohl. In Mohl's memoirs one of the most often repeated words is "Todesangst" (fear of death) which fits the situation in the half-flooded boiler room perfectly. He writes that after they finally

abandoned the fore boiler room half of his forty men could not reach the Oberdeck and perished.⁵⁰³

Ten minutes after the torpedo hits the *Szent István* hoisted the signals "Prepare for towing" and "Urgent" but on the *Tegetthoff* which began to zig-zag at full speed could not read these signals. At 4:20 a.m. the *Szent István* signaled the *Tegetthoff* with her searchlight ordering to take her in tow. Seitz hoped that the damaged battleship in the tow of her sister ship could reach the shallow waters of the nearby Bay of Brgulje where she could be run ashore. At 4:45 a.m. the *Tegetthoff* closed within earshot the *Szent István* when due to a false submarine alarm – not the first since the torpedoing – she moved off again. At 5 a.m. the *Tegetthoff* approached again her damaged sister and around 5:20 a.m. succeeded to connect the end of her towing cable to the *Tegetthoff*. At this time the starboard 15 cm guns of the *Szent István* were now under the water. As the list of the *Szent István* suddenly began to increase further the towing cable was cut on the *Tegetthoff*.⁵⁰⁴ The *Szent István* was now doomed, as more and more compartments were flooded through leaking joints and cable passages. Around 6 a.m. a loud booming sound was heard from the inside of the ship: probably the transversal watertight bulkhead between the boiler rooms broke under the pressure of the water. This event accelerated the agony of the ship: at 6:05 a.m. the *Szent István* capsized and at 6:12 a.m. sank.

Szent István is the only battleship whose sinking was filmed during World War I. The famous film footage of the battleship's last half-hour was taken by Linienschiffsleutnant Meusburger, one of the officers of the *Tegetthoff* with his own camera and by an official film crew. The two films were later spliced together. The *Szent István*'s sinking was one of only two on the high seas to be ever filmed, the other being that of the British battleship *Barham* in 1941.⁵⁰⁵

After the torpedo hits some seamen jumped into the water but mass panic was avoided. On Seitz's order the seamen in the water were picked by the torpedo boat 78. These seamen were later court martialed.⁵⁰⁶ Around 5:40 a.m. when it was clearly evident that the *Szent István* would sink Seitz ordered to abandon ship. He with Linienschiffskapitän Charles Masjon and other officers remained on the bridge. Allegedly Seitz was prepared to go down with the ship, but he and his

officers were thrown off the bridge when she capsized. They were rescued by the torpedo boat 81 and transferred to the *Tegetthoff*. Many seamen tried to reach the bottom of the slowly capsizing ship but the majority of them slipped down on her fouled side. Many of them were wounded from the sharp shells of the barnacles which covered in great quantity the underwater part of the hull. The *Tegetthoff*'s boats and the torpedo boats picked up 32 officers and 845 seamen until 7 a.m. From the rescued wounded one officer and twelve seamen died later. The final number of casualties was 1 officer and 13 seamen killed, 3 officers and 72 seamen missing and 29 seamen wounded. The *Tegetthoff* and her escort continued their way to Tاجر which they reached at 10:38 a.m.⁵⁰⁷

The ordeal of the seamen did not end at Tاجر. On Seitz's order three torpedo boats transported half of the surviving seamen to Sebenico where they were accommodated on the collier *Pola*. Probably Seitz thought that the operation would continue and the survivors would hinder the crew of the *Tegetthoff*. The second half of the surviving seamen would have been transported to Sebenico too, but in the meantime Hothy's order arrived to call off the action and to sail back to Pola. The *Tegetthoff* with the remaining survivors left Tاجر at 9 p.m. and arrived to Pola at 4:45 a.m. on 11 June. The fate of the men transported to Sebenico was the most shameful episode of the sinking of the *Szent István*. Approximately four hundred mostly half-naked or naked men were crowded on the narrow gangways of the *Pola* without any protection from the weather. For two days they were left there without water and food. On 12 June, they received some canned food and three days later, on 15 June clothes were distributed between them. On the morning of 17 June, the cruiser *Helgoland* arrived at Sebenico and transported the survivors to Pola. The men were compensated with a thirty days leave and 300 Kronen per head.⁵⁰⁸

Beside "Operation Korfu" there were plans for a closer cooperation between the Army and the Navy on the Piave Front. To discuss these plans a conference was scheduled for 10 June in the office of Vizeadmiral Alfred von Koudelka, the head of the Bezirkskommando of Trieste between the delegations of the Army and of the Flottenkommando. To their surprise instead of a delegation only one naval officer, Linienschiffskapitän Hermann Jobst

arrived from Pola on 10 June. Jobst informed them of the sinking of the *Szent István* and of the decision that with regard to the circumstances the fleet could not participate in the offensive of 15 June.⁵⁰⁹

On 10 June, the Navy informed the Military Chancellery of the Emperor of the sinking of the *Szent István* in a telegram: "Today at 3:30 a.m. *Szent István* was torpedoed near Premuda Island. At 6 a.m. she sank. Greatest part of the crew rescued."⁵¹⁰ On 6 July, the Marinesektion sent to the Military Chancellery of the Emperor five photos of the sinking battleship had been stuck into a piece of paper showing the different phases of the sinking.⁵¹¹ A board of inquiry was formed to investigate the causes and the details of the loss. The board was headed by Kontreadmiral Alfred von Cicoli, the head of the Hafenamiralität Pola and its members were Kontreadmiral Count Johann Firmian and Linienschiffskapitän Franz Lauffer. The board of inquiry sent its top secret report to the Marinesektion on 1 August 1918.⁵¹²

The first commander of the *Szent István* Kontreadmiral (from 1 May 1917) Edmund Grassberger was asked to write his opinion on the causes of the sinking. Grassberger fulfilled the request and wrote a lengthy comment dated on 10 July 1918. He wrote that the *Szent István* was much slower than the screw revolutions per minute/speed table indicated, especially at the time of her sinking because her underwater hull never had been cleaned since her commissioning. In his opinion this slowness made her an easy target. Grassberger – as many others – found the number of the escorting vessels insufficient. He considered that more energetic attempts to fit the collision mats could have saved the ship. Naturally he could not have known that the holes were much larger than the collision mats available. Grassberger blamed also for the loss the building quality of the *Szent István* especially the weakness of the watertight bulkheads. He summarized the question of responsibility in ten points. He mentioned among them the design flaws of the torpedo protection system, the low quality of the rivets and the riveting, the insufficient escort and the failure of fitting the collision mats.⁵¹³ While Grassberger liked to blame the Hungarian shipyard, the design flaws of the torpedo protection system and the weakness of the bulkheads were not primarily the Ganz and Co. Danubius's faults. For the design flaws of the protection system Siegfried

Popper, the designer of the ships was primarily responsible. The weakness of the watertight bulkheads of the *Tegetthoff* class battleships had been demonstrated now during the so called “caisson test” conducted in 1914.⁵¹⁴ According to Karl Freiherr von Puchner, who served on the *Tegetthoff*, after the loss of the *Szent István* the watertight bulkheads of the remaining three dreadnoughts were pressure tested. The result was surprising and disappointing: the bulkheads could not withstand the water pressure as on the *Szent István*.⁵¹⁵

The board of inquiry examined the following: the preparation of the operation, sailing to the site of torpedoing, the torpedoing of the *Szent István*, the rescue measures, the actions of the *Tegetthoff* and the secrecy. There was a little polemic over what orders for signaling had been issued by Seitz, but because all the secret orders and documents went down with the ship the board could not determine the truth. The board of inquiry made the following decision: Linienschiffskapitän Seitz as group commander was reprimanded for issuing orders for signals not visible enough. Linienschiffskapitän Masjon was reprimanded for failing to give the order to open the harbor boom in time. The *Tegetthoff*'s commander, Linienschiffskapitän Pergler was also reprimanded for failing to provide assistance in time. The board also bitterly criticized the leaders of the Empire for neglecting the Navy and for the low naval budgets which did not enable to build sufficient number of modern escorting vessels.⁵¹⁶ The reprimands did not really hinder the careers of Seitz and Pergler. Seitz in August was appointed to the commander of the Kreuzerflottille and on 1 November 1918 was promoted to Kontreadmiral. Pergler von Perglas remained the commander of the *Tegetthoff* until the end of the war and in March 1919 he became a titular Kontreadmiral. Masjon spent the remainder of the war on land in administrative positions.

About the design flaws of the *Szent István* the report of the board of inquiry wrote the following: “The first commander of the *Szent István*, Kontreadmiral Edmund Grassberger in his report presents the design flaws and defects which are characteristic for the other units of the *Tegetthoff* class too. The designer of the ship aiming at the greatest possible offensive power did not take into consideration the other equally important design requirements. This was noted at the time of the construction by

the supervising naval officers, but in vain because they had no authority to make changes. The ship's design in general was in accordance with the trends of the naval architecture of the time. However, it was a serious flaw that the distance between the armored torpedo bulkhead and the bulkhead of the 15 cm magazine was small.”⁵¹⁷ The board of inquiry proposed to inform Siegfried Popper that the board's report was containing the following paragraph. “The insufficient distance between the armored torpedo bulkhead and the bulkhead of the 15 cm magazine is a serious flaw which most probably helped to widen the hole. We propose to inform of this naval architect Kontreadmiral Siegfried Popper, the designer of the ship.”⁵¹⁸ It is very interesting that even in 1918 Grassberger and the members of the board did not understand that the real flaw of Popper's torpedo protection system was the insufficient distance between the armored torpedo bulkhead and the side shell plating.

The board of inquiry finished its work on 1 August 1918 and sent its top secret report to the Flottenkommando and Marinesektion. In the last paragraph of the report they did not recommend to court martial Seitz, Masjon and Pergler von Perglas, but instead only the ones who had left the torpedoed *Szent István* without being ordered.⁵¹⁹ The Flottenkommandant, Kontreadmiral Horthy and the Admiral zur Disposition der allerhöchsten Oberbefehls, Vizeadmiral Keil, were of a different opinion. Horthy proposed to court martial Seitz, Masjon and Pergler von Perglas primarily to reassure the public and the Parliament. He also proposed to entrust Vizeadmiral Keil with the conduct of the proceedings to avoid the conflict of interests because he, as Flottenkommandant had been also the C-in-C of the “Operation Korfu.” In mid-September 1918, the Chef der Marinesektion, Vizeadmiral Franz von Holub sent this proposal to the Emperor, who on 20 September approved it. At Keil's insistence Franz Pitzinger, Popper's successor, as the one who had officially approved the designs of the *Tegetthoff* class was also to be court martialled.⁵²⁰ Despite Keil devoting much attention to this matter in October, the four men were never tried thanks to the collapse of the Empire.

For many survivors of the sinking of the *Szent István* 10 June 1918 was the most remarkable day of their lives. No wonder that later at least a dozen of them, officers, petty officers and seamen put

pen to paper and wrote their memoirs on the event. The most notable Austrian memorialists were Maschinebetriebsleiter 1. Klasse Karl Mohl, Stabsmaschinewärter Franz Dueller⁵²¹ and Franz Scheiber. There are many Hungarian survivors who wrote their memoirs. The author of the longest and most detailed memoir is Ferenc Pintér, whose votive offering, a tiny anchor mentioned in the Preface, still hangs from the altar screen of the Serbian Orthodox Church of Szeged. Other Hungarian memorialists are Ferenc Magyar, János Szilágyi, Adolf Maritny, Antal Bicskey, János Kovács and the chaplain of the battleship József Sági, who is the main antagonist in Pintér's story.⁵²² Most of the above listed memorialists wrote more or less realistic and reliable memoirs, but naturally not without errors. Among them János Szilágyi was the too-imaginative one. Sometimes he drew the longbow: he wrote of Persian carpets, paintings of Titian and Rembrandt, banknotes, Egyptian cigarettes and Cuban cigars all over the deck.⁵²³ It is assumed that there are several other unpublished memoirs which perhaps will be discovered in the future.

The wreck of the *Szent István* lies upside down at a depth of 65 meters. Her bow broke off when she hit the seabed while her stern was still afloat. The four triple turrets are still in place, they did not fall out during the period of seven minutes when the capsized battleship was still afloat contrary to earlier speculation. Since the early 1990s several Austrian, Croatian and Hungarian diving expeditions have visited the wreck. Now the wreck is a protected site and has a war grave status. Some experts state that the wreck will collapse in the near future under its own weight.

The Sinking of the *Viribus Unitis*

After the unsuccessfully Piave offensive of the Monarchy in June and the successful Allied offensive on the Western Front in August it became evident that the Central Powers had lost the war. After the loss of the *Szent István* the Austro-Hungarian naval activity was mostly confined to submarine warfare. The 3 August report of Horthy to the AOK on the state of the fleet declared that the Navy was still ready for action. The Flottenkommandant announced that the mutinous spirit of Cattaro, the South Slav and political propagan-

da had been successfully repelled by harsh punishments⁵²⁴ and successful counter-propaganda. One type of cure to the internal problems of the Navy proposed by Horthy was the change of sailors with questionable loyalty to new recruits, but the number of the new recruits available was much less than was desired.⁵²⁵

The last battle fought by the Austro-Hungarian Navy was the Second Battle of Durazzo of 2 October 1918. A large Allied naval force, including Italian, British, American and Australian units attacked the Albanian port of Durazzo, then in Austro-Hungarian hands. Three Italian armored cruisers protected by the Italian dreadnought *Dante Alighieri* began to bombard the city. The two Austro-Hungarian destroyers, one torpedo boat and two submarines which were stationed in the port initially returned the Allied fire, and then successfully fled.

On 24 October, when the internal collapse of the Austro-Hungarian Monarchy was well underway, the Italian Army launched a major offensive. The defeat and the dissolution of the Dual Monarchy were imminent. On 26 October, Karl I informed Wilhelm II that the German – Austro-Hungarian alliance had come to an end, but the time for a separate peace had long gone. The Habsburg Empire was unsavable now. In April–May 1918, the Allies finally had decided for the dissolution of the Monarchy after the war, so every attempt to save it was now futile.

In the last days of October, the fleet in Pola was on the verge of mutiny. Horthy, desperately trying to maintain order on 27 October asked help from the AOK, but on the next day he was informed that the Army could not transfer troops to Pola. On 28 October, the larger warships were now in hands of their crews. On 29 October, the situation in Pola further deteriorated. Sailor's councils were controlling most of the warships, and some sailors began to loot in the city. The commander of the submarines, Franz von Thierry, suggested that he would use his boats against the mutinous ships but it would be against the direct orders of the Emperor. On the night of 28–29 October, a group of civilians under Italian flags broke the windows of the Marinekasino of Pola.⁵²⁶

On 29 October, the State of Slovenes, Croats and Serbs comprising the South Slav territories of the Dual Monarchy, was proclaimed in Zagreb.



64 *Viribus Unitis* sinking on 1 November 1918 in Pola

Through its short history this state remained unrecognized and on 1 December 1918 joined the Kingdom of Serbia to form the Kingdom of Serbs, Croats and Slovenes. On 30 October, a conference was held at Schönbrunn, with Emperor Karl, Chief of the General Staff Arthur Arz, Keil and Holub participating in it. This conference decided to turn over the fleet to the new South Slav state. The order, signed by Keil was cabled from the AOK to Horthy at Pola at the evening of 30 October. A little later the same telegram was cabled to the Hafenadmiralität of Pola, to the naval base of Cattaro, and to the Bezirkskommandos of Trieste, Fiume and Sebenico.⁵²⁷

Up to this day the question of who was the real originator of the turnover of the fleet, or what were the real motives behind it, are still open. Karl Friedrich Nowak, an Austrian journalist, in his 1923 book "Chaos" published his theory, that the turnover was made on Horthy's advice, and its

main purpose was to poison the relationship between the South Slavs and Italians. Horthy's former Chief of Staff, Emil Konek in his note of 1923 strongly denied this theory. He wrote that Horthy as Flottenkommandant in Pola in the last days of October 1918 was not in a position to propose anything. Konek stated that the real advisor was Vizeadmiral Keil. He wrote: "At the first moment this order shocked all of us. [...] A little later, re-considering it, this order seemed as a possible way to avoid the total loss of the fleet."⁵²⁸ In a memoir written in 1920 Karl argued that this decision prevented a violent South Slav takeover of the Navy.⁵²⁹

Horthy met the South Slav representatives on the morning of 31 October. The transfer ceremonies took place at 4:45 p.m. Horthy left his flagship, the *Viribus Unitis*, and a twenty-one gun salute greeted the raising the new flag.⁵³⁰ The commander of the *Viribus Unitis*, Janko Vuković was promoted to kontraadmiral and appointed to the commander of the Navy by the National Council of Zagreb.

In 1918 an Italian naval officer, Raffaele Rossetti developed a new, torpedo-like device intended to attack ships at anchor, which was capable to carry two divers and two magnetic mines, each filled with 180 kg of TNT, called *Mignatta* (Leech). Rossetti won over Raffaele Paolucci, a medical officer, to his cause. They planned to test the *Mignatta* under real circumstances in Pola harbor. They left little time because the armistice between Italy and the Monarchy was imminent. The last ideal date for the action seemed the moonless night of 31 October – 1 November. On 31 October a torpedo boat escorted by the MAS 95 carried the *Mignatta* from Venice near the Brioni Island. From there the MAS 95 towed the device 600 meters off the entrance of Pola harbor. Rossetti and Paolucci, vested in diver's suits, boarded the *Mignatta* and without any difficulty entered into the harbor. They passed the darkened battleships of the *Radetzky* class and continued their way toward the well illuminated *Viribus Unitis*, on which the South Slav crews were celebrating the transfer of the fleet. The two Italians succeeded, not without some difficulties, to attach one of the magnetic mines to the underwater part of the ship between the starboard 15 cm casemates No IV and V. They were spotted by a searchlight upon leaving the ship. In a hurry they armed the other mine and released the slow

moving *Mignatta* hoping that it would find another ship. Their wish came true, the steamer *Wien* of the Austrian Lloyd fell victim of the device.

The captured Rossetti and Paolucci were taken on board of the *Viribus Unitis* where they were surprised to learn that the fleet had been transferred to the State of the Slovenes, Croats and Serbs a dozen hours before. They told Janko Vuković de Podkapski, the last Austro-Hungarian commander of the battleship, who on the preceding day had been promoted to kontraadmiral by Zagreb, that they had attached a magnetic mine to the ship. Vuković immediately ordered abandon ship, the two Italians jumped into the water where they were picked out later by one of the boats of the *Viribus Unitis*. When the explosion did not occur at the time indicated by Rossetti, Vuković and his men returned to the battleship, bringing the two Italians with them. At 6:30 a.m. (other sources state 6:44 am) an explosion shook the ship when the magnetic mine detonated. The outraged sailors wanted to force their Italian prisoners to go down with the ship, locking them in a cabin. Vuković barely succeeded to talk them out of this inhumane act. Fourteen minutes after the explosion the *Viribus Unitis* capsized and sank. Rossetti and Paolucci survived the sinking, while their savior, Vuković perished. The exact number of the victims is unknown, because on those chaotic days no one administrated the number of the men on board or the number of the survivors. In the Pola cemetery there are around forty graves of the victims of the sinking of the *Viribus Unitis*. Estimates range between 50 and 400 deaths, the truth may be closer to 50.

On the sketches of the wreck made by the Italians in the 1920s it is clearly visible that the edge of the armored deck separated from the side shell plating which enabled the flooding of compartments above this deck, as had occurred in the case of the *Szent István*. Allegedly the watertight doors which had been closed and sealed at the start of the war were opened by the celebrating crew, which can help to explain the rapid sinking of the battleship.⁵³¹ The wreck was broken up by the Italians in the 1920s. Some parts of the ship are now on display in Venice: an anchor, together with the *Tegetthoff's* anchor and a small section of the bow.

Rossetti and Paolucci as prisoners of war were taken to a hospital ship. They were freed when the Italian Navy took control of Pola on 5 November.

They were presented with gold medals for bravery and they were awarded more than 1 million Lire from the Italian government as a reward for their services. The jealous Costanzo Ciano, the commander of the MAS flotilla in Venice demanded a part of the reward for himself stating that he had been co-inventor of the *Mignatta*. Due to Rossetti's protest Ciano was deprived of the reward.⁵³² Rossetti, who felt remorse, gave a great part of his reward of 650,000 Lire (1 percent of the value of the *Viribus Unitis*) to the widow of Vuković. The money was used to establish a trust fund for widows of other war victims. Rossetti later wrote a book and he offered the revenue to the family of Vuković. With the advent of the Fascism in Italy he founded an Anti-Fascist movement and later had to leave the country. Thanks to his activity the Italian government revoked his gold medal during the Spanish Civil War. Raffaele Paolucci, now conte di Valmaggiore, followed a political career during the Fascist regime beside his medical career, although he was rather a Monarchist than a Fascist. After his rehabilitation he continued his political career from 1953 until his death in 1958.

End of a Sea Power

After the turn over the fleet to the National Council of Zagreb, the non-South Slavs had to abandon the ships they had under their control. Over the next several days they had to organize the homeward journey of the other nationalities amidst the chaos. It was not an easy task, at least in the case of the Hungarians, because the majority of the Hungarian officers left Pola immediately after the turnover of the fleet, leaving behind their men. Only a handful of junior Hungarian officers remained in Pola to help organize the return of the Hungarian sailors which took place in the first days of November. The Hungarian committee which organized the return journey made an advertisement which was published in the newspapers of Pola thanking the South Slavs for their help in repatriating the sailors.⁵³³

The Allied Powers naturally did not recognize the turnover of the fleet, the Italians being especially angry. From 30 October, armistice talks took place at Villa Giusti outside of Padua between Italy and Austria-Hungary. The Austro-Hungarian

Navy was represented by Prince Johann Liechtenstein and Georg von Zwiernowski. The armistice was signed on 3 November. The Armistice of Villa Giusti authorized Italy to transfer five battleships, three cruisers, eight destroyers and a dozen torpedo boats among other units to Venice. This was done in March 1919. In this month the Italians held a victory parade in Venice, on this occasion on the masts of the former Austro-Hungarian ships the following signal was flying: "We have revenged Lissa".⁵³⁴ The armistice also authorized Italy to occupy all Austro-Hungarian Adriatic ports within 48 hours.⁵³⁵ Between 4 and 9 November, the Allied Powers occupied the former Austro-Hungarian ports, and (almost) all the warships came under Italian flag. The Italian government in the next months vehemently protested against the turnover of the former Austro-Hungarian Navy via the Swiss Embassy of Vienna, considering the transfer unlawful.⁵³⁶

On 7 November, her South Slav crew sailed the battleship *Zrínyi* to Buccari, a port not yet occupied by the Italians. Days later the US Navy seized the ship, which came under US flag as USS *Zrínyi* until the distribution of the former Austro-Hungarian fleet. In the Cattaro naval base all the flags were cut in small stripes, which the crews brought home to prevent them falling in the enemy's hands as a last act of defiance.⁵³⁷

Negotiations to determine the fate of the former Austro-Hungarian fleet began on Corfu in early November 1918. The leader of the Italian delegation, contraammiraglio Ugo Conz, concluded that the former Austro-Hungarian Navy in Yugoslav hands would represent an unacceptable threat to Italy. He said: "The Austro-Hungarian fleet must either be given to Italy or destroyed."⁵³⁸ The representatives of other powers, especially the British showed some sympathy to the South Slavs, because they were disgusted by the arrogance of the Italians. Nevertheless, it was out of question that any of the victors would accept the transfer of the fleet.⁵³⁹

The fate of the former German and Austro-Hungarian fleets generated considerable debate and disagreement. The interned German fleet was scuttled by the German crews of the ships in Scapa Flow in June 1919. After this act the debates continued over the fate of the former Austro-Hungarian fleet, and the Allies postponed the final decision to 1920. The distribution of the fleet was made in 1920 by the Naval Allied Commission of Disposal of Enemy Vessels (NACDEV). The overall spirit of naval disarmament which culminated in the Washington Treaty of 1922 sealed the fate even of the most modern battleships. With the exception of the three *Helgoland* class cruisers, all of the former Austro-Hungarian warships larger than 1,000 tons were scrapped or destroyed in the early twenties.

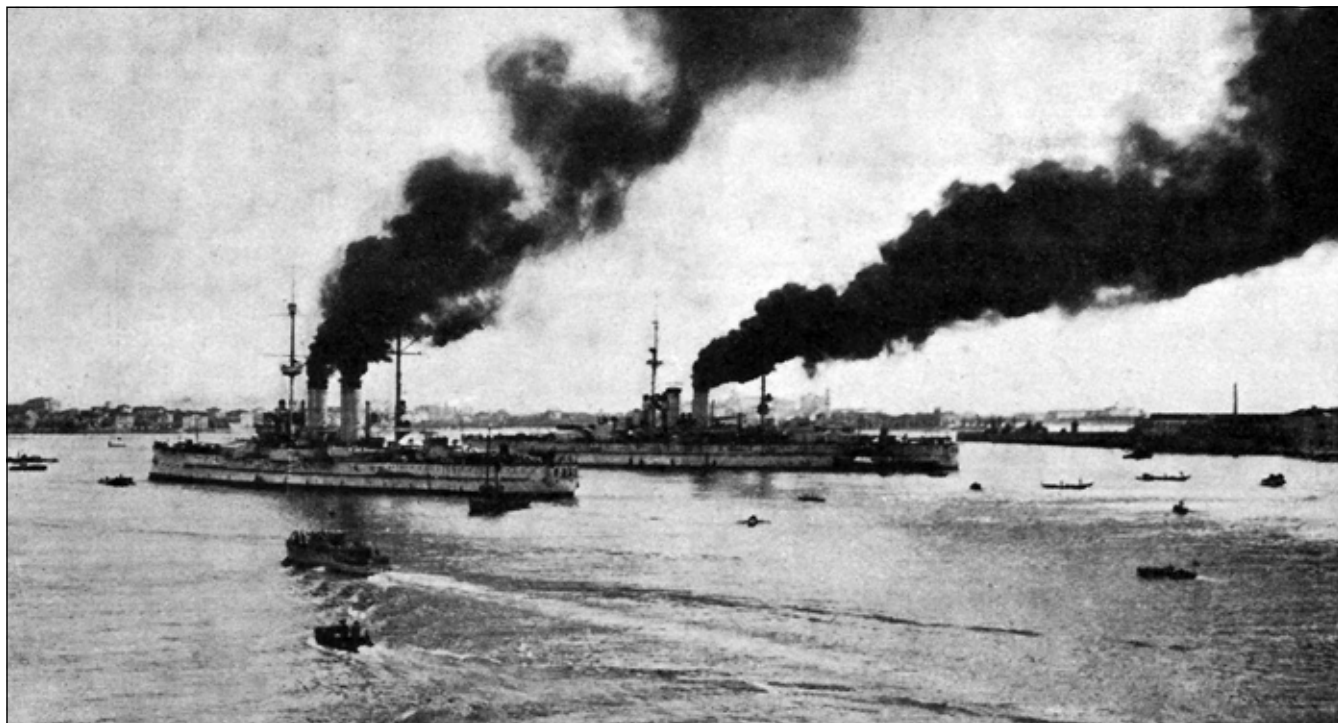

65 Erzherzog Franz Ferdinand and Tegetthoff paraded in Venice in March 1919

The three units of the *Radetzky* class and the two remaining dreadnoughts were distributed between Italy and France in May 1920. All the three *Radetzky*s were transferred to Italy. The *Tegetthoff*, which had been in Italian hands since March 1919, was officially transferred to Italy and the *Prinz Eugen* was transferred to France. The distribution of the two dreadnoughts was not lacking a certain symbolism. The eponym of the *Tegetthoff*, Wilhelm von Tegetthoff had defeated the Italian fleet at Lissa, while the eponym of the *Prinz Eugen*, Prince Eugene of Savoy had achieved victories over the French during the War of Spanish Succession. All five battleships were transferred with the proviso that they should be scrapped within five years.

The *Erzherzog Franz Ferdinand* was scrapped at Ancona in 1921-1922, the *Radetzky* at Pola in 1921-1922 and the *Zrínyi* also in 1921-1922. In the case of the *Tegetthoff* the Italians tried to stall for time, finally she was demolished in 1924-1925 after their former allies had put pressure on Italy. The guns and other valuable fittings were removed from the ships before sending them to the breakers yard. Some equipments of the fire control system of the *Tegetthoff* are now on display at the Technical Museum of Milan. The French intended to

use the *Prinz Eugen* as a target ship. She was towed from Pola to Toulon, where she arrived in September 1920. In the first months of 1921 her guns, machinery and all other fittings were removed from her. In May 1921, the *Prinz Eugen* was used as a target ship for aerial bombs. She withstood well the bombing, even the largest bombs inflicted little damage on her. Next, in January 1922, her torpedo protection system was tested with a torpedo warhead. As in the case of her sisters, the torpedo bulkhead could not withstand the underwater explosion, and the entire compartment behind it was flooded. Because the water was leaking through the makeshift sealing of the bulkheads which had been made after the removal of the pipes and electric cables, neighboring compartments were also flooded and the ship sank in the shallow water. The *Prinz Eugen* was salvaged and repaired in Toulon. On 28 June 1922, she made her final journey. She was towed to ten nautical miles off Toulon, where she was used as a target ship for the 34 cm and 30.5 cm guns of the French dreadnoughts which sank her. This is how the story of the last two and largest Austro-Hungarian battleship classes ended. Their construction had cost the taxpayers of the Empire 360.4 million Kronen, equivalent of 109 metric tons of gold.

AUSTRO-HUNGARIAN HEAVY NAVAL GUNS, GUN TURRETS AND FIRE CONTROL

From the early 1870s until 1901, the German firm of Krupp had been the exclusive supplier of heavy ordnance to the Austro-Hungarian Navy. The first domestic heavy naval guns, classified as 24 cm/40 was manufactured in 1901 at the Škoda Works of Pilsen. For this occasion, a committee was convened which decided to retain the Krupp breech mechanism. The first capital ship armed with Škoda large caliber guns was the standard battleship *Babenberg*. The Škoda 24 cm/40, which was more or less of a Krupp-clone, served on four battleships and one armored cruiser. In the period between 1904 and 1914, the Škoda developed three new heavy gun types: the 24 cm/45, the 30.5 cm/45 and the 35 cm/45, the last used only as land artillery. This chapter describes in detail these guns as well as the gun turrets and the fire control system of the battleships which were actually built.

Austro-Hungarian Heavy Naval Guns

In September 1905, during the design process of the battleships later called the *Radetzky* class the design board decided that the vessels would have a main armament of 30.5 cm/45 guns. Later in this year another decision was made to increase the caliber of the secondary battery from 19 cm to 24 cm. The Škoda Works, which was enjoying a virtual monopoly of Austro-Hungarian naval ordnance, had to develop two new gun types for the 14,500 ton battleships. The first was the 30.5 cm/45 gun. The manufacturing of this weapon began in the summer of 1909. In 1909-1910, the Škoda manufactured thirteen 30.5 cm guns (12+1 spare), the majority of them (11) being ready in December 1909.⁵⁴⁰ It is worth mentioning that the Škoda 30.5 cm/45 gun was twenty percent more expensive than the Krupp 30.5 cm/50 gun.⁵⁴¹ The second gun type which was developed by Škoda for the *Radetzky* class was the 24 cm/45. The Czech firm made twenty-seven 24 cm/45 guns (24+3 spares) for these battleships. The 30.5 cm and the 24 cm guns had horizontal wedge breeches which

were hand operated only. The Austro-Hungarian 30.5 cm guns, unlike the German 30.5 cm guns, did not use fore charges, all the propellant charge was in a single brass cartridge. These brass cartridges could be reused 8 to 10 times.

During the first phase of the design of the next battleship class (*Tegetthoff* class) which went on until April 1909, a new type of gun, the 30.5 cm/50⁵⁴² was favored by the Navy. In April 1909, a rumor spread that the Škoda was having problems with the development of the longer gun. With the advent of the twelve-gun battleship design with the guns mounted on four triple turrets, the Navy returned to the 30.5 cm/45 gun. Originally these guns were planned to be entirely identical with the ones built for the *Radetzky* class.⁵⁴³ In 1910, the Austro-Hungarian Navy approved a new type of propellant which was somewhat weaker than the previous propellants.⁵⁴⁴ Due to this decision, Škoda had to slightly redesign the existing 30.5 cm/45 gun. The new gun's chamber was 5 cm longer, so that it could handle the longer cartridge with a heavier propellant charge which would be needed to achieve the same muzzle velocity with the weaker powder. The guns could use also the older, shorter cartridges. The new gun was designated as 30.5 cm/45 K10 (K means *Konstruktionsjahr*, year of construction).⁵⁴⁵ The previous variant was officially designated as "30.5 cm SK L/45" where SK means *Schiffs-Kanone* (naval gun). Škoda manufactured fifty-two 30.5 cm/45 K10 guns (48+4 spares).

In the summer of 1911, when the design of the second dreadnought class began, the Navy decided to introduce a new caliber. First the 34.5 cm caliber was taken into consideration. Beside this caliber the Navy studied the possibility of introducing the 35.5 cm caliber. It is clear from the documents that the Škoda did not waste time on working on the design of the 35.5 cm gun, but they produced detailed 34.5 cm/45 twin and triple gun turret designs with any-angle loading in two versions. The 34.5 cm gun mounted on these turret designs weighed 73 tons and its projectile's weight was 650 kg. Achieving a muzzle velocity of

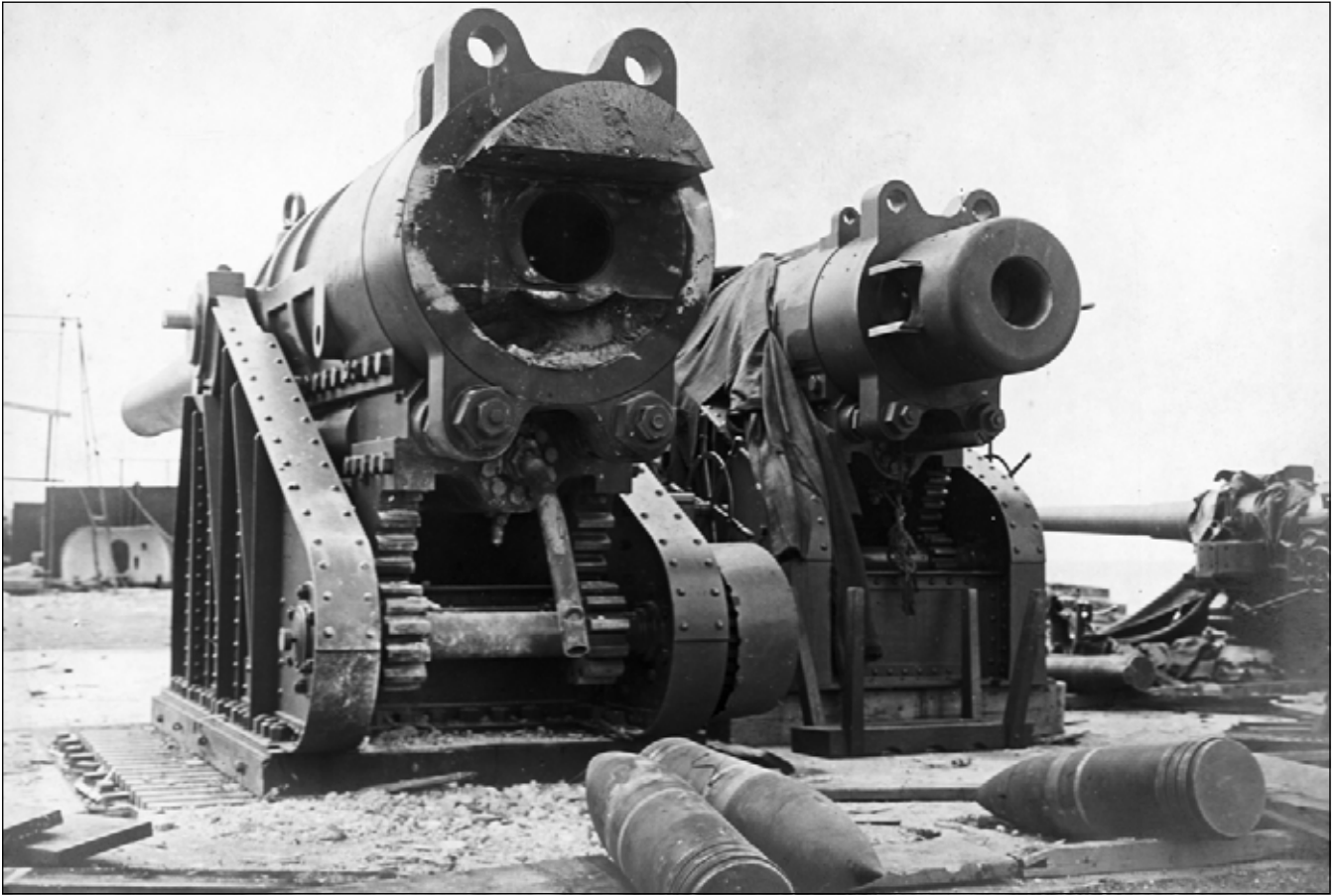

66 *The gun on the left is a 30.5 cm/45 which exploded on 21 August 1913, killing Vizeadmiral Karl Lanjus von Wellenburg and three sailors. Shells in the foreground are cast iron practice rounds.*

The gun on the right is a 24 cm/45. Photograph taken on the Saccorgiana test ground near Pola

800 mps it needed a propellant charge of 205 kg. It is interesting that all the propellant charge was again in a single, very large and heavy brass case. This case was around 1,800 mm long and its empty weight was 97 kg.⁵⁴⁶ The use of such a large case was possible only because on these turret designs with any-angle loading the handling of the spent cartridge case was mechanized.

On 25 June 1912, a board which examined the battleship designs decided that the guns of the new battleships would be yet another new size, 35 cm/45. In July 1912, the Navy asked Škoda to work on the designs for 35 cm twin and triple turrets. With the introduction of the 35 cm caliber the Navy chose to follow the German practice of splitting the propellant charge into two parts by using a fore charge forward of the main charge, else the single brass cartridge would have been overly large and unwieldy, at least in a turret with a fixed loading angle (see above). The greater part of the propellant charge was in a brass cartridge, which

was even so considerably larger than the one for the 30.5 cm gun. While the German fore charges were in a double silk bag, the fore charge of the Austro-Hungarian 35 cm gun was in a thin (0.5 mm) brass casing which burned during firing. Unlike the previous Škoda heavy guns, the breech block for the new weapon would have been pneumatically operated, but in case of emergency it could also be operated by hand. The units of the 24,500 ton battleship class were cancelled after the outbreak of the war, but the first batch of the 35 cm guns (10+1 spare) was still ordered from the Škoda Works. The first barrel (Rohr Nr 1) was ready in November 1914. The first tests with this gun were executed at Pilsen on 20–21 November 1914. During the tests, the gun fired eight 635 kg projectiles at muzzle velocities between 819 and 823 mps. The test committee recommended reducing the muzzle velocity down to 800 mps in order to reduce wear and improve barrel life. As a naval gun it was officially designated as “35 cm SK L/45 K14”. Two or per-

haps three 35 cm guns were completed during the war, and they were used as land artillery on the Italian and on the Romanian fronts where they were designated as “35 cm M16.” Plans were made to use them as railway guns, but these were never realized.

The Škoda large caliber naval guns were so called “all steel” guns: the barrels of the guns were made from massive steel castings. The barrels were constructed so that the breech mechanisms could be opened either to the left or to the right, facilitating their use in the triple turrets. In order to preserve the material, the barrels were kept in oil baths for several weeks after they were finished. The maximum gas pressure when the guns were fired was 2,900 atm. The barrel life of the Škoda heavy naval guns was about 200 rounds, after this it was advisable to re-line the gun. If a barrel was to be re-lined, the outer tube was removed by means of hydraulic presses and placed on a new lining, somewhat larger in outer diameter.⁵⁴⁷ The first 35 cm gun (Rohr Nr. 1) fired 122 rounds on the Italian Front, before it was returned to the Škoda Works. In the factory it was found that the gun chamber was damaged but that the gun was still serviceable.⁵⁴⁸

All of these guns (24 cm, 30.5 cm and 35 cm) had similar slides, differing mostly in size. Škoda large caliber naval guns, unlike Krupp heavy naval guns, had vertically symmetrical Hornrings⁵⁴⁹ with two holes above and below the gun barrel for the recoil/counter-recoil attachments. Recoil cylinders and run-out cylinder were attached to the underside of the slide and their piston rods were attached to the lower portion of the Hornring. The run-out cylinder was between the two recoil cylinders. Run-out was done by 125 atm compressed air. On the upper part of rear end of the slide there was a similar half-ring to the half-Hornring, with two attachment holes. When the gun was not in use, two bars (bolts) were attached to the upper portion of the Hornring and to the half-ring of the slide which locked the barrel to the slide. Elevation gears of these guns were arc and pinion style, so massive twin arcs protruded from the underside of the slide.

For the new guns it had to develop new projectiles, even for the longer 24 cm guns. Before the war two types of projectiles were used for heavy

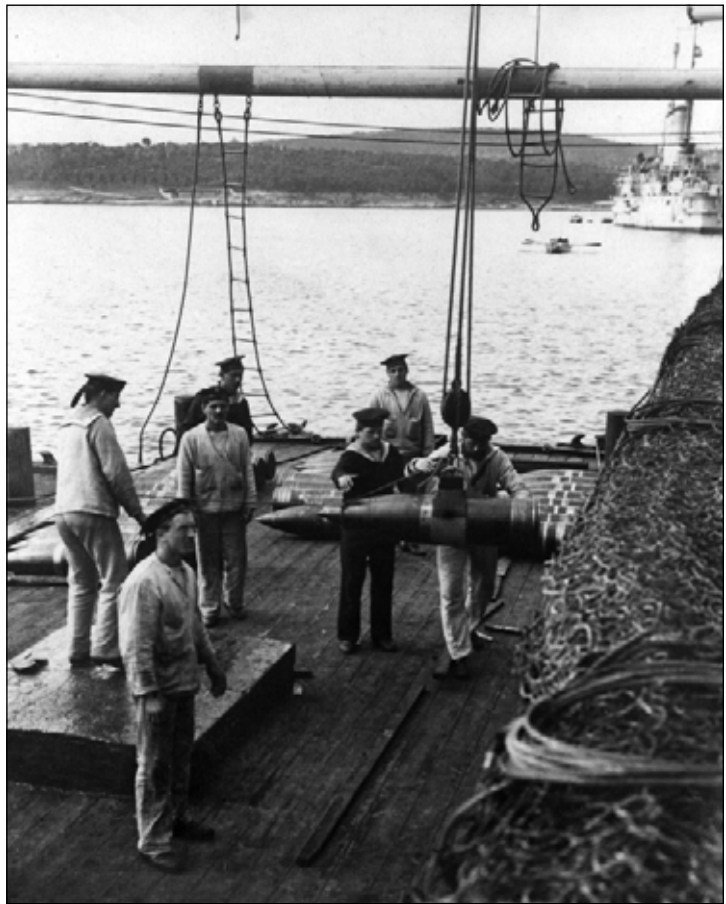

67 Sailors loading 30.5 cm 5crh projectiles in 1915.
Note the torpedo nets in the foreground
and an Erzherzog Karl class battleship in the background

naval guns: (bekappte) *Panzergranate* (APC) and *Zündergranate* (HE). Some sources suggest that capped AP projectiles were introduced first on the *Habsburg* class battleships after the turn of the century. For the 24 cm/45 guns a new APC known as the 24 cm P. Gr. M/08 was developed which was used exclusively on the *Radetzky* class battleships. This projectile weighed 215 kg and was more expensive than the old APCs of the 24 cm/40 guns.⁵⁵⁰ A new HE shell, the 24 cm Z. Gr. M/08 was also developed for this gun, which also had an AP cap. The projectiles of the 30.5 cm/45 guns weighed 450 kg. At least two types of APCs were developed for these guns, but some sources suggest that during the war a third, newer and more expensive 30.5 cm APC was also introduced. Official documents state that the size and weight of the AP caps of the APCs for the non-K10 (*Radetzky*) and the K10 (*Tegetthoff*) guns differed in size and weight.⁵⁵¹ There were also two different types of 30.5 cm HE projectiles: one not fitted and one fitted with an AP cap.⁵⁵² These 24 cm and 30.5 cm capped HE

projectiles, while the weight percentages of their bursting charges were between 5.93 and 8.1 percent, fell rather in the SAP category due to their considerable armor penetration. This was also true for the projected 35 cm HE projectiles.

In 1914, the Austro-Hungarian Navy considered to introduce *Einheitsgranate* (or *Einheitsgeschöß*) for the 30.5 cm guns. *Einheitsgranate* was a lighter APC with greater bursting charge and it was a preferred type in the German Navy. From June until October 1914, the Navy tested this new type of projectile at least four times on the Saccorgiana test ground near Pola.⁵⁵³ Immediately after the outbreak of the war the Navy asked some factories to make an offer for the 30.5 cm *Einheitsgranate*.⁵⁵⁴ The range table of the 30.5 cm/45 K10 gun from the first half of 1914 contains also the armor penetration data of the *Einheitsgranate*.⁵⁵⁵ However, the official booklet on the fuzes used in the Navy published in 1917 does not list the 30.5 cm *Einheitsgranate* which suggests that this type of projectile was not adopted for the Navy.⁵⁵⁶

Until around 1911-1912, Austro-Hungarian naval projectiles were not fitted with ballistic caps. The aerodynamically adverse form of the projectiles without ballistic caps, especially in the case of the blunt-nosed capped APs, badly affected the range and the armor penetration at every range. The Navy was aware of this phenomenon and around 1912 ballistic caps were introduced. An internal report on the Austro-Hungarian naval artillery suggests that the 30.5 cm and 24 cm projectiles used on the *Radetzky* class were fitted with 4.5crh ballistic caps.⁵⁵⁷ The larger ammunition hoists of the *Tegetthoff* class battleships could accommodate longer shells, so the 30.5 cm projectiles intended for the dreadnoughts were fitted with 5crh ballistic caps.⁵⁵⁸ An interesting fact: in the 1910s AP caps and ballistic caps were manufactured under the license from the British firm Firth and Sons, Limited, in the Dual Monarchy. This monopoly on the cap design was protected by patents both in Austria and in Hungary.⁵⁵⁹

During the first phase of the design process of the “*Improved Tegetthoff*” class battleships the introduction of the 34.5 cm or the 35.5 cm calibers were considered. The projectile weight of these guns would have been 650 kg and 700 kg respectively. In June 1912, the Navy finally decided for the 35 cm caliber. For this caliber a lighter, 635 kg

projectile was chosen. For the 35 cm/45 K14 naval guns four types of projectiles were developed: one APC, one *Einheitsgranate* (light APC) and two different HEs. All these projected shells including the HEs had an AP cap and a 5.25crh ballistic cap. Based on theoretical calculations the 35 cm *Einheitsgranate* would have had similar armor penetration capability as the 30.5 cm APC.⁵⁶⁰ Because the “*Improved Tegetthoff*” class battleships were cancelled in 1914/1915 the few (2 or 3) 35 cm guns completed were used as land artillery. Redesignated as 35 cm M16 they fired totally different shells which had been developed for land use.⁵⁶¹

All the 24 cm and 30.5 cm projectiles were fitted with the same base fuzes designed by Škoda. Most probably the same fuzes were intended also for the 35 cm naval shells. The B. Z. M/09 (*Boden Zünder*, base fuze) were manufactured in two variants: one instantaneous type for the HE shells and one delay type for the APC projectiles. The M/09 fuze had a ball bearing safety device (*Kegelsicherung*). When the projectile reached its maximal rotation after leaving the barrel the centrifugal force removed the small steel balls which blocked the firing pin.⁵⁶² The M/09 fuze contained a 200 gram booster charge of so called “Blumauer Pulver” (corned black powder). Allegedly this fuze was too sensitive and shells with this fuze sometimes exploded in the air due to the sensitivity of the fuze.

The internal report on the Austro-Hungarian naval artillery from 1912 states that the bursting charges of the larger caliber shells were made of TNT.⁵⁶³ Because TNT was expensive and its manufacturing was import-dependent in the Dual Monarchy, TNT was replaced with T-Ammonal (*Amatol*, mixture of TNT and ammonium nitrate). T-Ammonal was cheaper and less import-dependent. The 35 cm projectile drawings made in July 1913 show T-Ammonal (T. A.) bursting charges. The form-pressed pieces of explosive were wrapped in thick paperboard. Usually, two pieces of pressed and wrapped explosive were loaded into the APCs and three pieces into the HEs. At the top of the bursting charge in the nose end of the hollow part of the shell body a wooden shock absorber was placed. Between the wrapped pieces of explosive felt discs were placed. When the bursting charge was loaded into the shell molten wax was used as gap filler material.

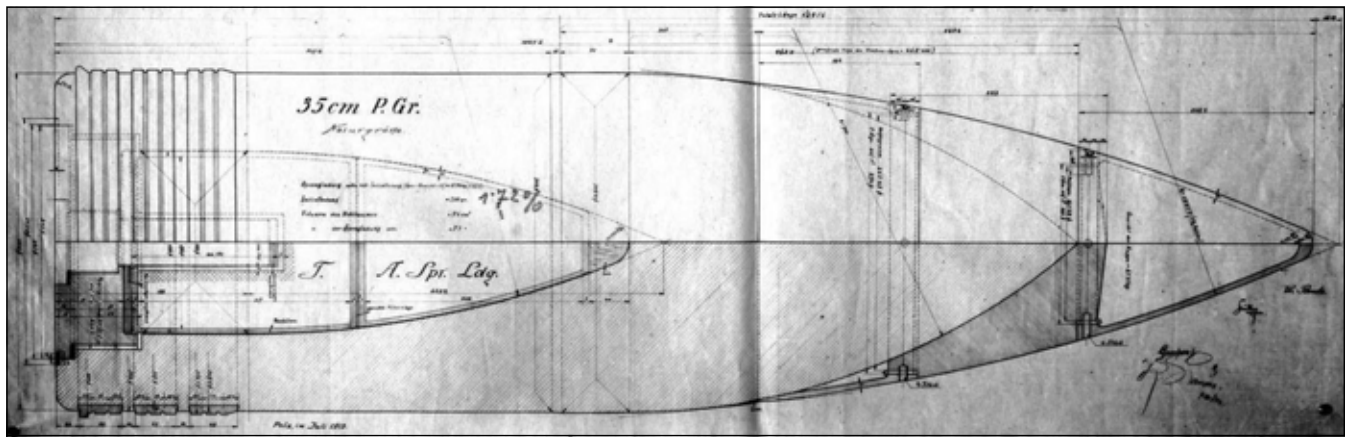

68 35 cm APC projectile with 5.25crh ballistic cap. Note the wooden shock absorber at the top of the burster

In 1892, the Austro-Hungarian Navy started using a single-based “smokeless powder” designated as M/92 consisting of 100 percent nitrocellulose. Like other pure nitrocellulose propellants of this time, the M/92 was unstable and in 1893 the Navy switched to a double-based nitrocellulose/nitroglycerin propellant designated as M/93. This also had no stabilizer elements and again proved unstable. In 1897, the Navy introduced a new double-based propellant designated as M/97 that included barium nitrate as an oxidizer and vaseline (petroleum jelly) as a stabilizer. This proved more stable than the earlier propellants and became the basis for all subsequent propellants in use until the end of World War I. Over the next two decades, the percentages of the ingredients of this propellant were changed several times but all were known as M/97 with a letter suffix indicating the change.⁵⁶⁴

Almost all propellants were manufactured in the form of hollow tubes (*Rohrenpulver*). Rohrenpulver was used in most guns 12 cm and larger. At the time of the commissioning of the *Radetzky* class battleships the standard propellant for the large caliber naval guns was the R. P. M/97f. It was composed of 62% nitrocellulose (12.6% nitrogen content), 25% nitroglycerin, 8% barium nitrate and 3% vaseline. For the 24 cm/45 and 30.5 cm/45 guns it was manufactured in tubes of 21 mm outer diameter and of different lengths – 580 mm for 24 cm and 660 mm for 30.5 cm guns.⁵⁶⁵ As was mentioned previously, in 1910 the Navy planned to introduce a new, somewhat weaker propellant for the 30.5 cm guns of the future *Tegetthoff* class. The internal report on the naval artillery states that this new propellant was intended exclusively for the 30.5 cm/45 K10 and 15 cm/50 guns of the

dreadnoughts.⁵⁶⁶ The composition of this propellant is unknown at this time. One source suggests that the 35 cm/45 gun as land gun used the older M/97f propellant; the outer diameter of the tubes was 23 mm and the length of them 703 mm.⁵⁶⁷

The M/97 propellants were safer than the French or Italian propellants, at least in the Austro-Hungarian Navy there were no catastrophic magazine explosions like in the other two navies; while magazine cooling issues were not uncommon on Austro-Hungarian ships during the hot Adriatic summers. Reportedly, propellant charges which caught fire burned and did not explode. M/97 propellants were manufactured in the Pulverfabrik Blumau in Austria, owned by the Heeresverwaltung (Military Administration) and in the Dynamit Nobel factory in Pozsony, Hungary.

One of the unique features of the Škoda large caliber naval guns – thanks to the close technical relationship to the Krupp guns – was that they had wedge breech blocks as opposed to the screw breech blocks of the bag guns used by the other sea powers excluding Germany. Consequently, the propellant charge of these guns was in a massive brass case. Unlike German guns of the same calibers which had a fore charge the 24 cm and 30.5 cm Škoda guns used a single brass case which contained all of the propellant charge. The empty case of the 30.5 cm gun weighed around 69 kg. The first Austro-Hungarian naval gun which used a fore charge was the 35 cm/45 gun, but this gun never entered into naval service. This gun used a relatively small, 50 kg fore charge which was in a thin, 0.5 mm brass casing. The greater part of the propellant charge was in a large brass case which weighed 78 kg empty.⁵⁶⁸ The propellant was in silk

**Technical Data of the Large Caliber Austro-Hungarian (Škoda)
Naval Guns Developed After 1904⁵⁷¹**

	<i>24 cm/45 Radetzky class</i>	<i>30.5 cm/45 Radetzky class</i>	<i>30.5 cm/45 K10 Tegetthoff class</i>	<i>35 cm/45 K14 "Improved Tegetthoff" class</i>
Actual bore diameter	240 mm	305 mm	305 mm	349.5 mm
Gun Weight	27,700 kg	54,634 kg	54,650 kg	74,000 kg
Gun Length oa	10,800 mm	13,725 mm	13,750 mm	15,750 mm
Rate of Fire	2 rounds/pm	1-2 rounds/pm	1-2 rounds/pm	1-2 rounds/pm
Ammunition Type	Separate, propellant in a single brass cartridge	Separate, propellant in a single brass cartridge	Separate, propellant in a single brass cartridge	Separate, main propellant charge in a brass cartridge, fore propellant charge in thin brass casing
Projectile Types and Weights	APC: 215 kg HE (SAP): 215 kg	APC: 450 kg HE (SAP): 450 kg	APC: 450 kg HE (SAP): 450 kg	APC: 635 kg HE 1: 635 kg HE 2: 635 kg Einheitsgr: 635 kg
Projectile Length	APC: 820 mm HE: 997 mm	APC: 1036 mm HE: 1229 mm	APC: N/A HE: N/A	APC: 1292 mm HE 1: 1500 mm HE 2: 1469 mm Einheitsgr: N/A
Bursting Charge	APC: 2.4 kg HE: 17.4 kg	APC: 4 kg HE: 26.7 kg	APC: N/A HE: N/A	APC: 10.9 kg HE 1: 42.5 kg HE 2: 37.7 kg Einheitsgr: 18.5 kg
Propellant Charge	70 kg	137 kg	142 kg	Main: 156 kg Fore: 49 kg
Cartridge Empty Weight	32.95 kg	69.5 kg	68.53 kg	Main: 78 kg Fore: 0.9 kg
Muzzle Velocity	800 mps	800 mps	800 mps	800 mps
Range	12° 1' - 12,000 m 20° - N/A	13° 50' - 15,000 m 20° - N/A	16° - 19,000 m 20° - 22,000 m	16° - N/A
Armor Penetration (APC) KC Side Armor	5,000 m - 193 mm 10,000 m - 107 mm	5,000 m - 433 mm 10,000 m - 202 mm 15,000 m - 143 mm	5,000 m - 502 mm 10,000 m - 273 mm 15,000 m - 208 mm	5,000 m - 590 mm 10,000 m - 450 mm 15,000 m - 346 mm

bags and these bags, two in the case of the above mentioned guns were loaded into the brass case. The inside of the cases were painted with a so called "orange lacquer" to prevent corrosion caused by the

propellant.⁵⁶⁹ The separate cartridge cases were fully enclosed, their mouths plugged by a brass lid. This lid was fired along with the shell. The igniter, which was in the center of the base of the case,

was protected by a mechanical device which was removed before loading.

The brass case had its advantages and disadvantages. This type of propellant container allowed higher rates of fire and was less likely to catch fire in case of damage from a shell hit. It was also less likely to suffer a flareback type of disaster caused by the smoldering remnants from the previous propellant charge. However, it had to be removed from the gun and be safely handled out of the turret after firing. This could be uncomfortable in the cramped gunhouses of the large caliber gun turrets. For ejecting the spent cases from the turret there were holes cut in the footplate at the rear part of the gunhouse. The ejected heavy caliber cases rolled freely back and forth on the open deck around the turrets. After a firing practice or engagement, the expensive cases were collected and inspected. Large caliber cases were reusable 8 to 10 times. Cases which were considered no longer reusable were sent back to the factory for recasting. After 1910, fifty percent of all the naval cases were manufactured by the Weiss Manfréd Works in Csepel, Hungary and the other fifty percent by different Austrian (and Czech) factories.

Unfortunately, there is little information to judge how accurate and reliable were these Škoda 24 cm/45 and 30.5 cm/45 naval guns. The seven largest and most modern Austro-Hungarian battleships never fired their guns in anger on an enemy ship. Six of the seven ships participated in the Bombardment of Ancona in 1915 when they fired on land targets and one ship, the *Radetzky* bombarded the French batteries in Montenegro in 1914. Two ships, the *Szent István* and the *Erzherzog Franz Ferdinand*, never fired their 30.5 cm guns in anger. The report on the bombardment of the French batteries on Mount Lovčen found the accuracy of the 24 cm and 30.5 cm guns of the *Radetzky* satisfactory.⁵⁷⁰ The most serious accident of a large caliber Škoda gun occurred on 21 August 1913 when an overloaded 30.5 cm/45 gun exploded on the Saccorgiana test ground near Pola. The explosion killed three sailors and seriously injured Vizeadmiral Karl Lanjus von Wellenburg who stood near the gun. His lower legs were amputated and he died on the next day in the hospital. There are some reports of minor accidents but in the majority of cases it was found that they were caused by mishandling by the gun crews. For the battleships

as a weapon system, it was not the guns but the obsolete fire control system that was the weakest link.

Gun Turrets

The gun turrets of the *Radetzky* and the *Tegetthoff* classes were all-electric operated, as would have been the turrets of the “*Improved Tegetthoff*” class. Turrets were fed by steam turbine driven dynamos providing 110 Volt DC current. The documentation of the Škoda 30.5 gun turrets is rather incomplete, but the available plans, documents and the 1/25 scale *Viribus Unitis* model suggest that on these turrets Ward Leonard control was used. The Škoda presented its first 30.5 cm triple turret design to the Navy in October 1909. According to this design the firm planned to use so-called Universal-transmissions on the triple turret. The Universal-transmission was a hydraulic, variable speed transmission driven by an electric motor, which had the same function as the Ward Leonard control.⁵⁷² One year later for an unknown reason Škoda abandoned the idea of using electro-hydraulic turret machinery and the September 1910 triple turret design incorporated the Ward Leonard control.⁵⁷³ The complete gun turrets of the battleships actually built were manufactured by the Škoda Works, excluding turret armor, fire control equipment and some safety devices.

The revolving portion of an Austro-Hungarian gun turret (gunhouse and rotating turret stalk) rested on the stool (Untersatz), which was a massive construction made of steel plates inside the barrette on the Batteriedeck. The bottom part of the ball path was attached to the top of the stool, while the top part of it was attached to the underside of the gunhouse. Austro-Hungarian gun turrets, like Germans, rested on steel balls of 16-17 cm diameter instead of rollers. The ring gear of the training gear (Backszahnkranz) was attached to the bottom part of the stool. There were hold-down clips (Klauen) to prevent the turret from upsetting when the guns were firing. The bottom of the rotating stalk rested on a central pivot. Through this center pivot entered into the turret the electric cables, the compressed air pipelines and the air duct of the turret ventilation.

All of the 24 cm and 30.5 cm twin turrets had four flats (levels) in their rotating stalks. Lower tri-

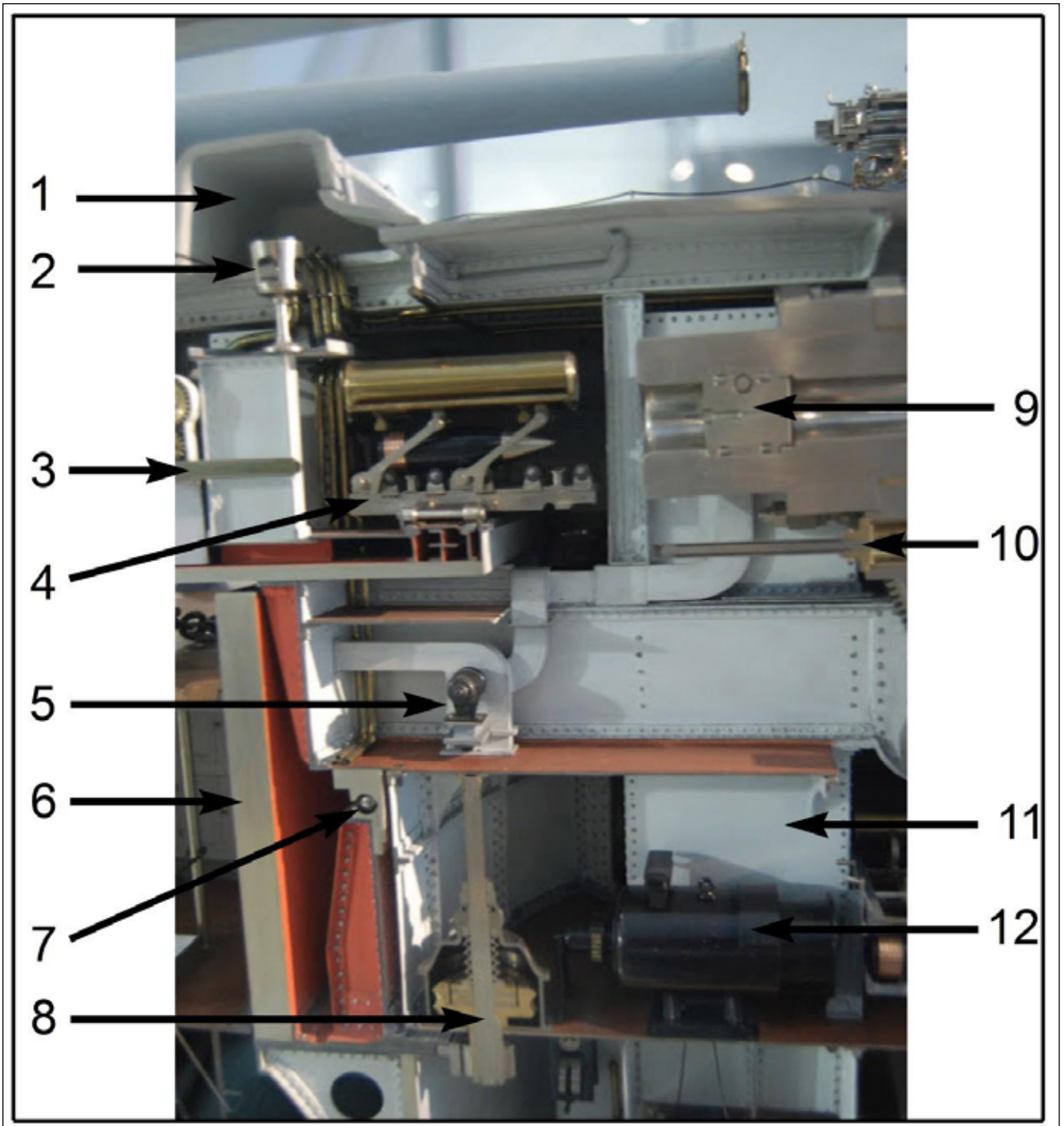

69 A part of the 30.5 cm/45 triple turret on the 1/25 scale model of the Viribus Unitis at the Heeresgeschichtliche Museum, Vienna (courtesy of Heeresgeschichtliche Museum, Vienna, photo: György Koltai, graphic: Kristóf Csákváry)

- 1 Armored cupola for turret rangefinder (the rangefinder is missing)
- 2 The seat of the turret commander
- 3 Telescopic chain rammer
- 4 Loaded loading car, cartridge above, projectile below
- 5 Propellant gas exhausting ventilator of the central gun
- 6 Barrette armor (280 mm)
- 7 Stool and ball race on which the revolving part of the turret rests
- 8 Training gear (worm gear)
- 9 Horizontal sliding wedge breech block of the central gun
- 10 Run-out cylinder of the central gun working by 125 atm compressed air
- 11 Main ammunition hoist of the central gun
- 12 Electric training motor (98 HP)

ple turrets had five flats;⁵⁷⁴ superimposed triples had an additional flat. These flats were numbered from the top to the bottom, so the first flat was directly underneath the gunhouse and gun pit. The training gear, the handling room (Umladestation; which did not mean a true handling room like on contemporary British turrets), the elevating gears (on the ceiling) and the control stations of the ammunition hoists were on the first flat. In these handling rooms it was possible to store 12 complete rounds in the twin turrets and 16 in the triple turrets. The electric motors and winches of the main hoists, the hand powered emergency gears of the main hoists and a part of the similar emergency training gear were on the second flat. Also, there were the electric motor and generator sets of the Ward Leonard system, one large set for the training motor and two or three small sets for the elevation motors. In the case of an emergency, it was possible to train the turret with one of the hoist motors. On the third flat of the twin turrets were the cartridge handling room and the rotatable cartridge ring (Patronendrescheibe). In the lower triple turrets, the motors and the winches of the auxiliary hoists were on the third flat, these were on the fourth flat in the superimposed triples. In triple turrets the cartridge handling room and the cartridge ring were on the fourth/fifth flat. On the bottom flat (fourth in twins, fifth/sixth in triples) were the projectile handling room and the rotatable projectile ring (Geschossdrescheibe).

As previously mentioned, the turrets could operate entirely by manpower when needed. However, the Navy soon realized that under realistic conditions the turrets were practically inoperable by manpower. Various solutions to maintain the operability of the turrets during a power failure were introduced over the years. The turrets for the *Prinz Eugen* and *Szent István* were originally constructed with auxiliary pneumatic motors for the ammunition hoists.⁵⁷⁵ Training the heavy triple turrets by hand was possible only on the calmest sea and even that was at a snail's pace. To solve this problem (at least on triple turrets) a 20 HP auxiliary crude oil engine was installed in each turret, coupled to the emergency training gear through a Universal-transmission.⁵⁷⁶

Twin and triple turrets were almost identical in the terms of ammunition handling. Main ammunition hoists (Hauptaufzug) ran directly from

the lowest flat to the gunhouse and came up between the guns. The hoist of the center gun of the triple turret was on the left side of the gun. On the twin turrets there were two tube-like auxiliary hoists (Nebenaufzug), which ran directly from the lowest flat to the gunhouse and came up on outside of the guns. The larger barbette diameter (9.6 m vs. 7.8 m) of the triple turrets made it possible to build in these turrets two auxiliary ammunition hoists forward of the left and the right main hoists. These auxiliary hoists were identical to the main ammunition hoists. In the gunhouse of the triple turret the left main and auxiliary hoists and the right main and auxiliary hoists were connected with metal trays. Prasky states in his book that on the *Prinz Eugen* and the *Szent István* the auxiliary hoists ended on the first flat.⁵⁷⁷ However, a blueprint of the compressed air pipelines for the turrets of these two ships dating from March 1913 contradicts to this statement. On this plan the auxiliary hoists also run from the lowest flat up to the gunhouse.⁵⁷⁸ The main hoists of the twin and the main and auxiliary hoists of the triple turrets had bi-level cars moved by four cables. In these cars the complete round of ammunition was transported in horizontal position, projectile on the lower level and the cartridge on the upper level of the car. These hoists had large non-closeable openings in the forward and rear walls of the hoist trunks in the gunhouse, in the handling room and in the projectile and cartridge handling rooms. So, it seems that flash protection was on the bottom of the priority list of the turret designers. Maybe this was a result of the typical prewar thinking which fetishized rapid rate of fire. They may think, partly correct, that the lack of flash protection was not such a big issue than it was in the case of bag guns, because Austro-Hungarian propellant was fully encased in brass cartridges. Moreover, Austro-Hungarian powder was less dangerous than the British cordite, in the case of a hit it burned rather than exploded. During the war, thanks to the German experiences, the practice of cartridge handling changed significantly.

On both battleship classes the shell rooms (Geschossen-Depot) and magazines (Patronen-Depot) were located on the same level, the Plattformdeck, which was well under the waterline. Shell rooms for the bow turrets were forward of the turret trunk, magazine aft. Stern turrets had a reversed

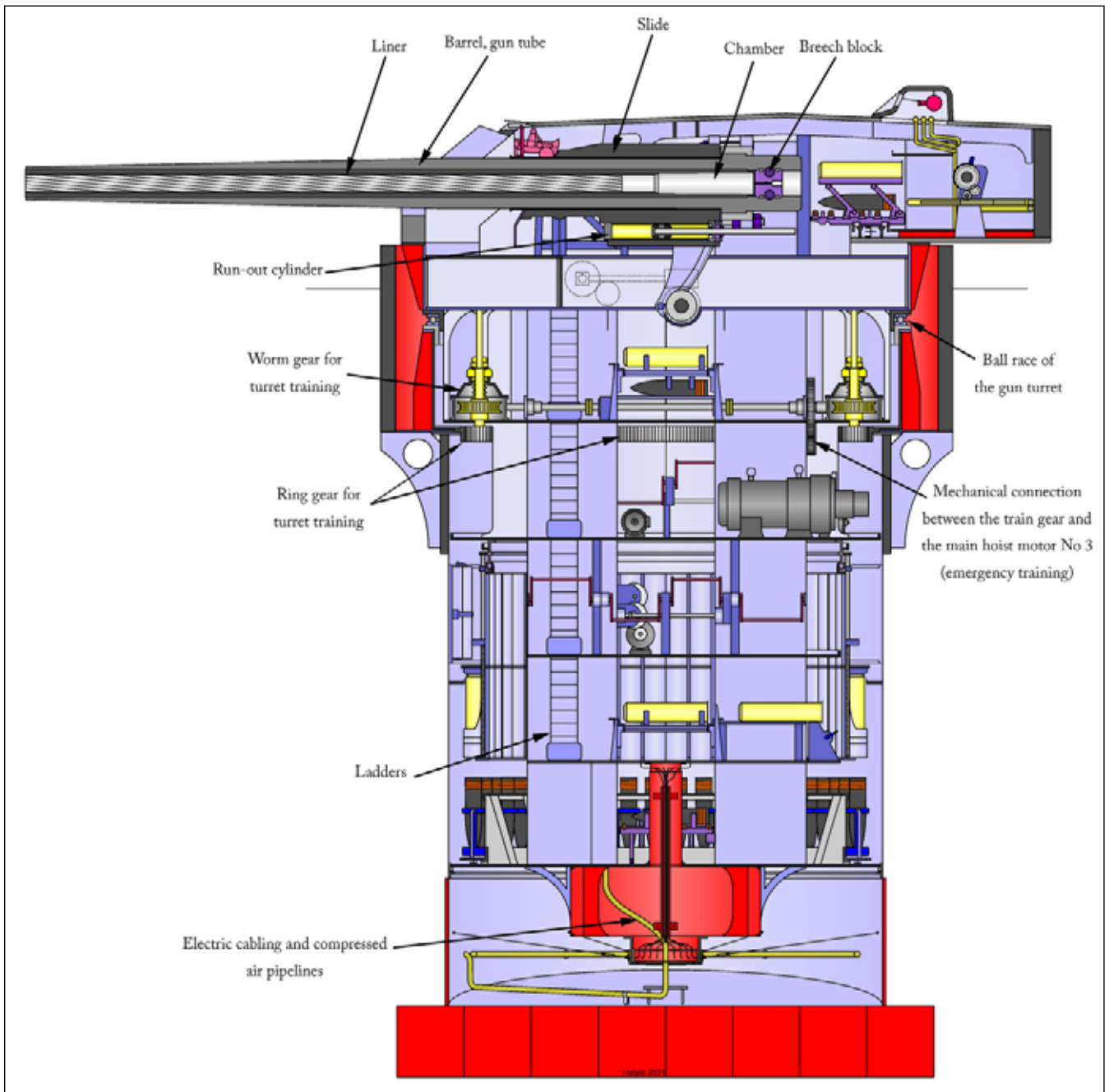

70 Longitudinal section (above), cross section (opposite page and page 160) and plan views (on the page 161-163) of the Turret No I of Viribus Unitis

arrangement. In the shell rooms the projectiles were stowed hanging from roof chains pointing nose down, and they were moved by travelling hoists. Cartridges were stowed horizontally. Projectiles were transferred from the shell room to the rotating turret stalk hanging in vertical position on rails attached to the fixed turret trunk, and they were loaded into the projectile ring. The individual projectile-bins of the projectile ring could be tilted into horizontal position, and the projectiles were transferred to the hoist on rails. The capac-

ity of the projectile ring of the 30.5 cm twin turret was 30 projectiles, while the ring of the triple turret held 40. In the magazine two hoists were installed, which brought the cartridges up to the next deck level (Zwischendeck). From here the cartridges were transferred to the revolving stalk, and were loaded into the upper cartridge ring. Twin and triple turrets had double cartridge rings, a lower and an upper, the lower was immediately above the projectile ring. Cartridge rings had the same capacity as the projectile rings. The lower projec-

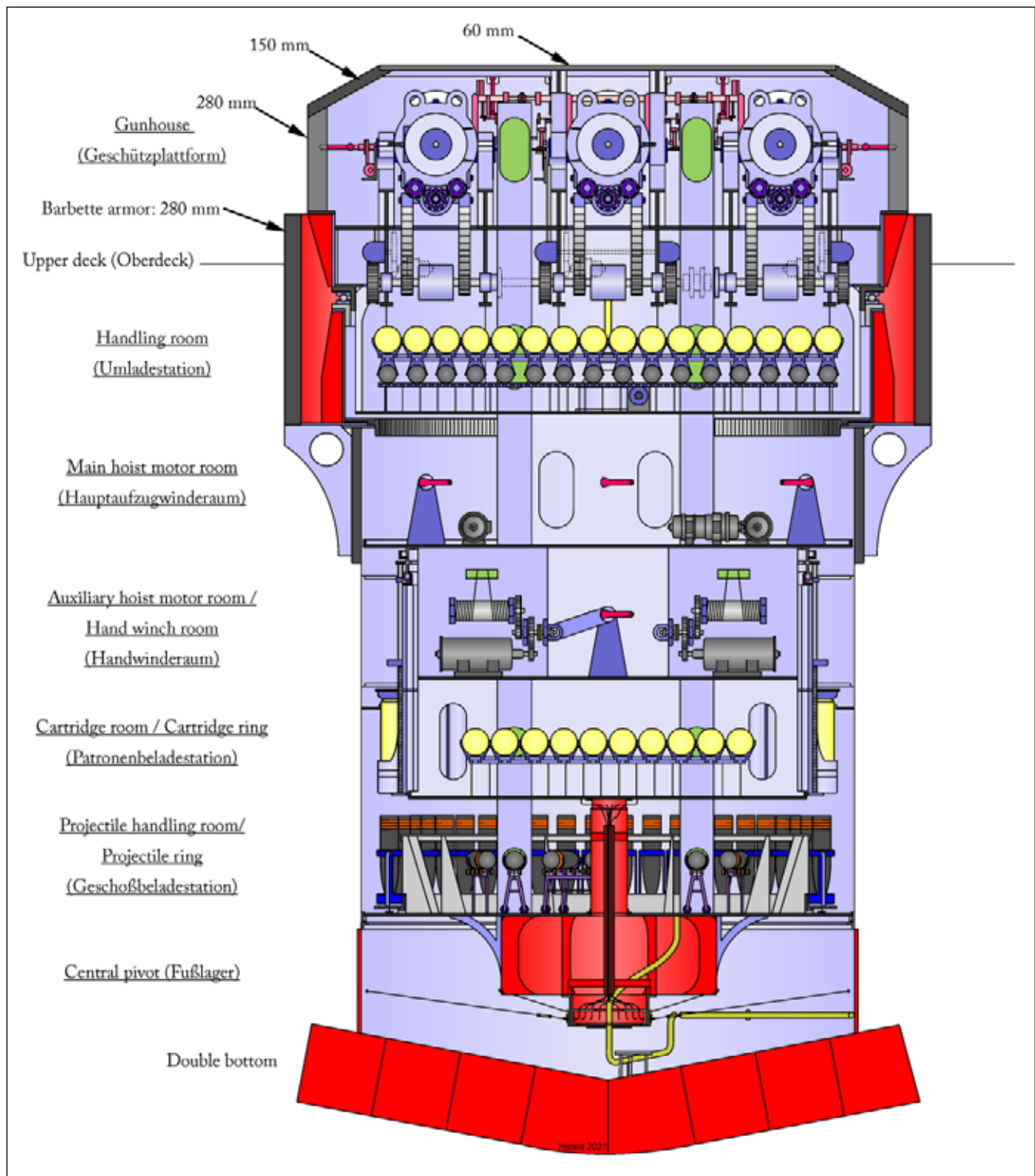

tile ring could be loaded directly from the magazine. Cartridges were transported from the rings to the hoists in a different way as the projectiles. The cartridges were transferred sliding on two trays to a central table which was between the main and the auxiliary hoists. From this table they could be loaded either into the main or the auxiliary hoists. The projectile ring and the cartridge rings could be rotated by hand gears.

In the minds of the turret designers the highest priority was a high rate of fire. The possibility of storing a great quantity of projectiles and cartridges inside the revolving stalk served the purpose of transferring the ammunition to the gunhouse by the fastest possible way. The revolving structure could hold around 60 projectiles and 80 cartridges in the 30.5 cm twin turret, while the triple mountings could hold 87 projectiles and 109

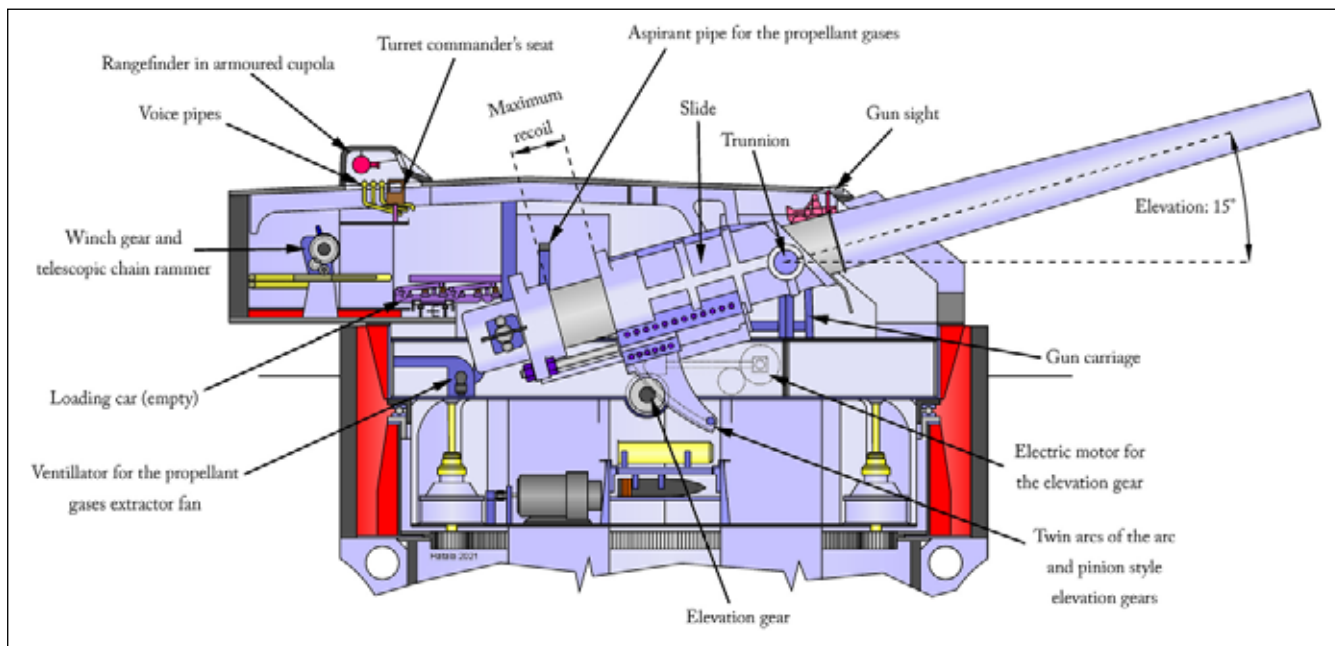

cartridges. In the case of the triple turret, this meant that there was more than 15,000 kg propellant powder inside the stalk without flash protection other than the brass cartridges. In the case of the so called rapid fire the auxiliary hoists fed the handling room on the first flat, and main hoists brought up the ammunition from here to the gunhouse, which reduced hoisting time from 8-11 seconds down to 3.5 seconds⁵⁷⁹

German experiences of the Battles of Dogger Bank and Jutland/Skagerrak showed how dangerous it was to store propellant charges between the magazine and the gunhouse. On the other hand, it was a reassuring sign, that while some German gun turrets burned out completely due to turret or barbette hits in both battles with the loss of the entire or almost entire turret crews, the ships themselves were spared from catastrophic magazine explosions, unlike the three British battlecruisers at Jutland.⁵⁸⁰ We know that the Austro-Hungarian Navy intensively studied the German experiences after the Battle of Jutland. The Austro-Hungarian naval attaché in Berlin, Count Heinrich Colloredo-Mannsfeld wrote a lengthy report on the battle in June, a few weeks later a team of Austro-Hungarian naval experts (mostly engineers) travelled to Germany and inspected the battleships and battlecruisers which had participated in the battle.⁵⁸¹ The lessons were well-learned. In 1915, after Dogger Bank the Navy abandoned the practice of storing cartridges in the handling room. After analyzing the German experiences of the Battle of Jutland, the

Austro-Hungarian Navy in the spring of 1917 decided for radical changes in ammunition handling in the 30.5 cm turrets. We know from plans made by Škoda in May 1917 that the complete elimination of the cartridge rings in the turret stalk was the main scope of these changes, along with a new method of transferring cartridges from the magazine to the turret stalk. These plans show double flap doors installed in the magazine.⁵⁸² Because the documentation is far from complete, we don't know if these changes were actually implemented or not.

In the gunhouse behind the guns and the main hoists there were bi-level loading cars (Munitionswagen) that ran across the turret on rails. Each gun had its own loading car but it was possible to feed every gun by every car. The loading trays of the cars were at the same level with the openings of the main hoists. Behind the rails in line with the longitudinal axis of the guns there were massive dual purpose winch gears operated by three men. These gears operated alternately the loading cars and the rammers. The loading cars were moved by cables which ran under the footplate between the rails. These gears also operated the chain and telescoping rammer (Gelenkzahnstangenstzer Patent Škoda). The long chains were stored in metal tubes attached to the side walls of the turrets. Ready round projectiles were stowed in great box-like structures between these winch gears, 9 on the twin and 18 on the triple turrets. The weight of these projectiles was needed for proper balancing of the turret.

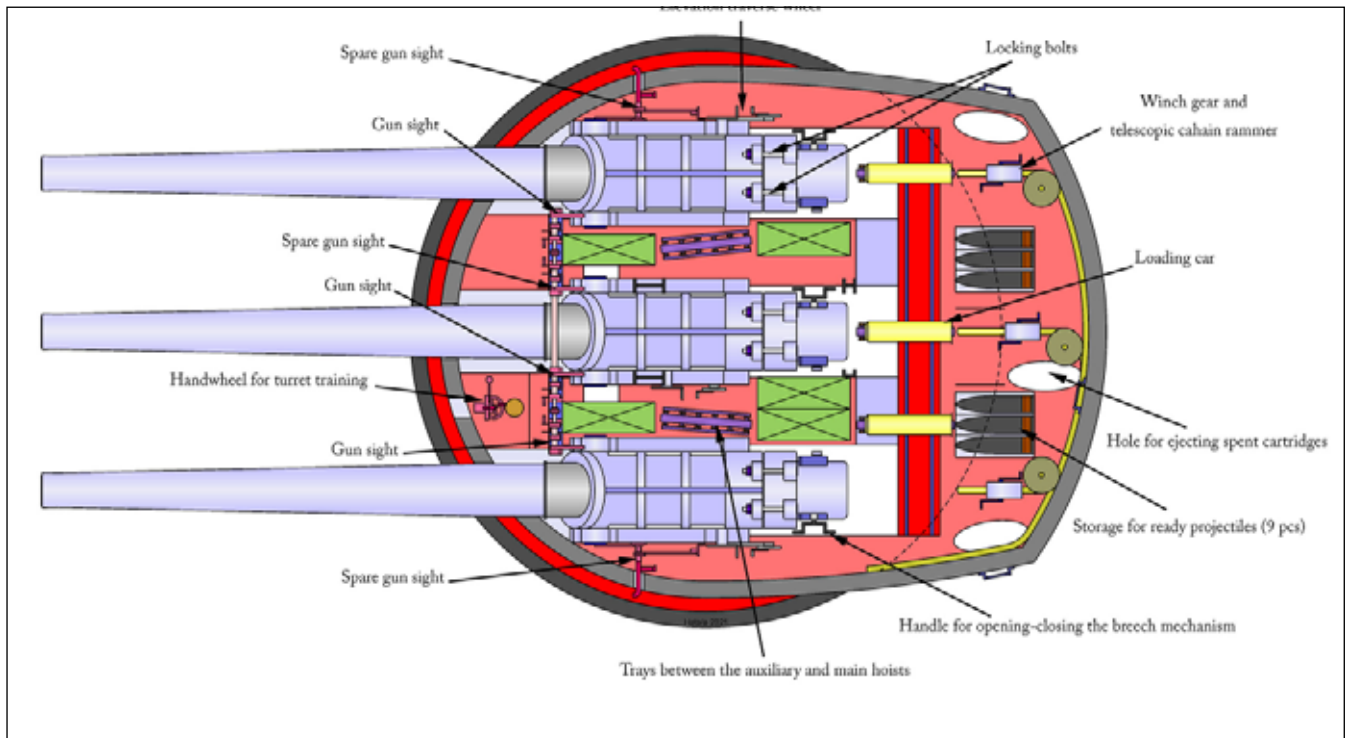

The method of unloading the hoist cars was rather primitive. There were no rammers installed for this purpose. Once the hoist car was up, a lever which was attached to the hoist trunk was pushed down. Then the short metal bars which secured the projectile and the cartridge in place at both ends of the hoist car, were turned by 90 degrees. This was possible only when the loading car was in the correct position. Then the gun crews had to pull the projectile and the cartridge onto the loading car by hand. For the projectile there were rubber rollers, for the cartridge only a simple metal tray. After the gun was fired and lowered to the loading position (+2.5 degrees), the slide was locked. The breech operator (Verschlussmann) opened the breech by hand. On the other side of every gun there was an extractor fan used to expel the propellant gases from the breech.⁵⁸³ When the breech was open, the spent cartridge was extracted. There were large holes in the footplate in the rear part of the gunhouse for ejecting the spent cartridges. Metal plates were laid down around the barbette to protect the precious teak deck. Then the loading car was moved behind the gun. The projectile was rammed first and then the cartridge tray was unlocked, which slowly lowered to the loading position under the weight of the cartridge then the cartridge was rammed. The ramming cycle was 12 seconds. In rapid fire mode it could achieve a fire cycle of a little less than 30 seconds, but it depend-

ed strongly on the training and physical strength of the turret crew. Normal firing cycle was between 40 and 80 seconds. A 30.5 cm twin turret had a crew of around 65-70 men, and the triple turret had a crew of 90 men.⁵⁸⁴

On the twin and triple turrets the guns were individually sleeved. The elevation range for the guns mounted on twin turrets was $-4/+20$ degrees. Originally the *Viribus Unitis* and the *Tegetthoff* were able to elevate their guns to 20 degrees. In 1913, the Navy ordered to build in the triple turrets a coupling device (Mechanische Kupplung für Lagenfeuer) to elevate and depress the three guns together.⁵⁸⁵ The Navy hoped this method would result in better hit probability.⁵⁸⁶ Turrets of the *Prinz Eugen* and *Szent István* were originally constructed with these couplers. The battleships of the *Tegetthoff* class still were able to individually elevate their guns, but the coupler limited the maximum elevation of the center gun to 15.5 degrees and of the outer guns to 16 degrees, so the maximum range of these battleships dropped from 22,000 m down to 19,000 m. The elevation rate of the 30.5 cm guns was 3 degrees per second and the train rate of the 30.5 cm turrets was 6 degrees per second.

Each gun port of the 24 cm and 30.5 cm turrets originally had a three-part metal lid. These lids could be closed only when the guns were locked in the loading position. During the war these lids were replaced with blast bags. On the turret roofs

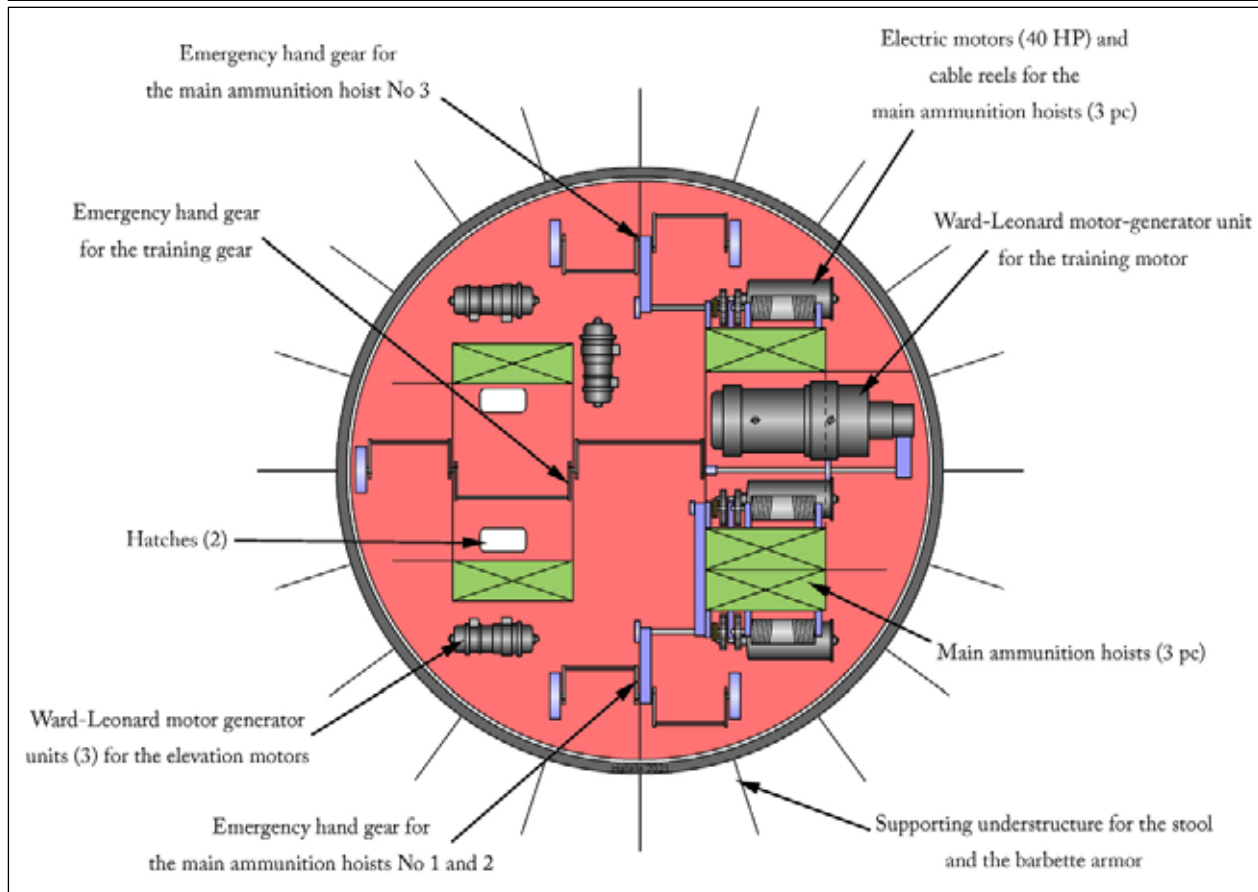
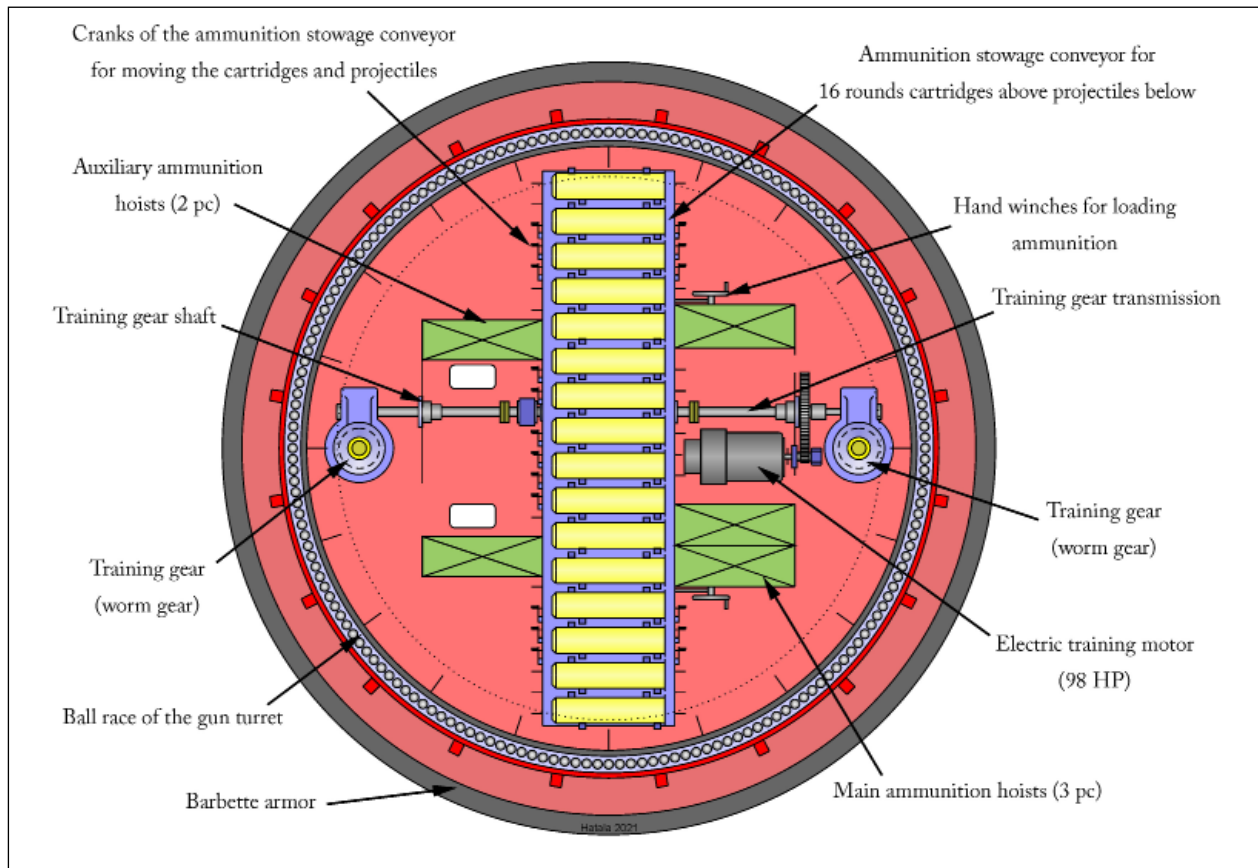

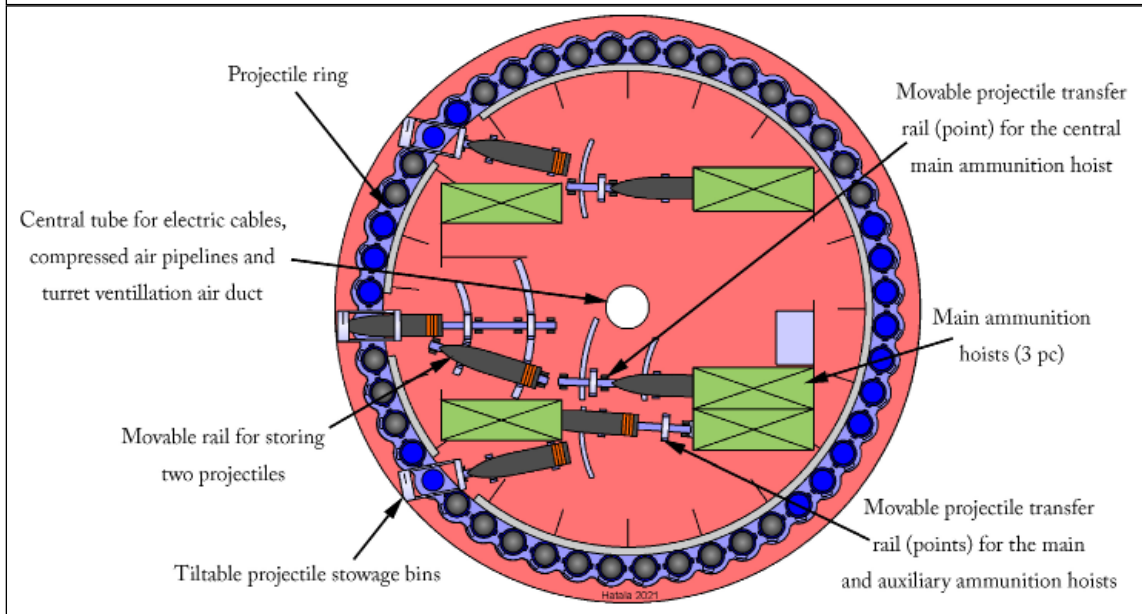
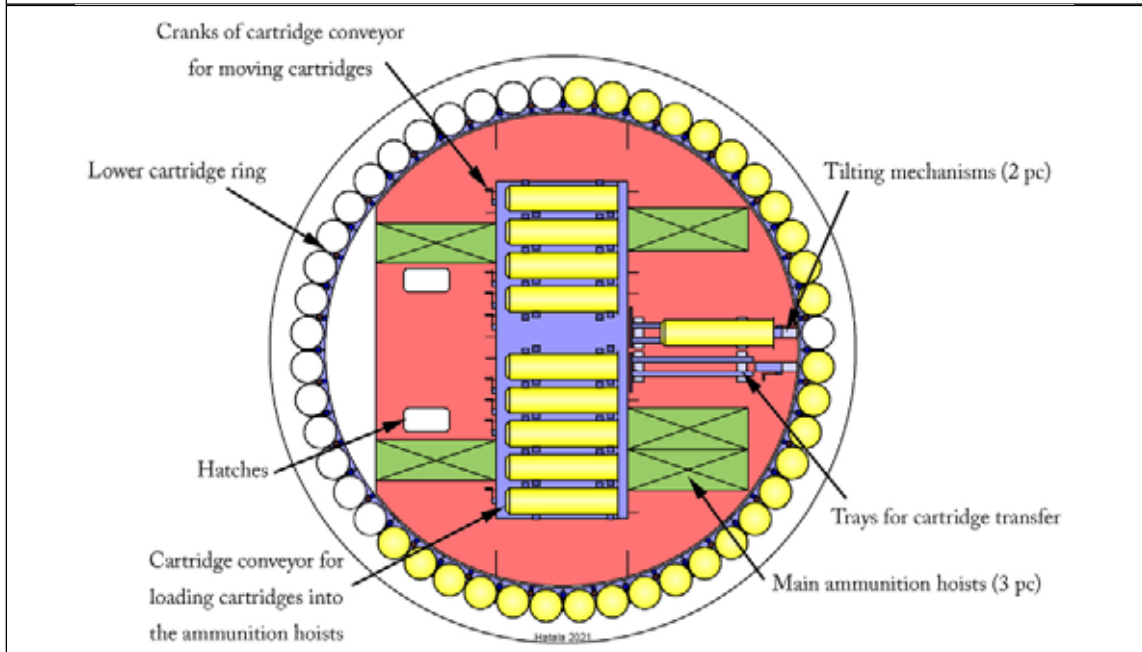
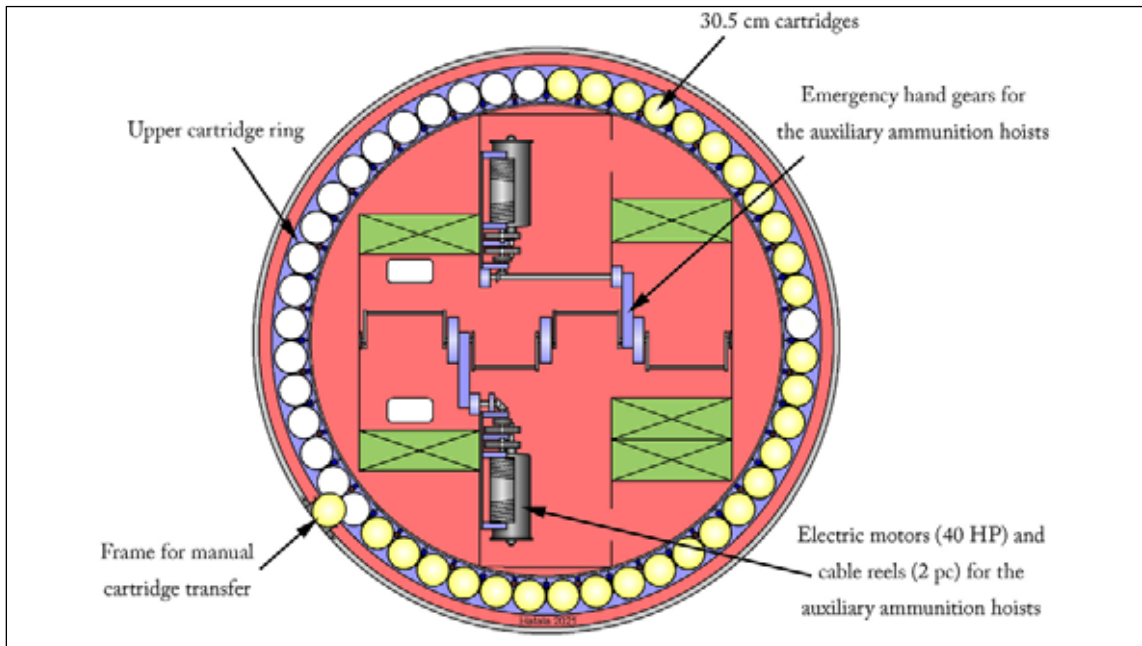

originally, there were pivot rings for 7 cm/50 guns on transferable center pivot mountings (Abkom-mkanone). These guns could be connected with steel rods to the heavy guns of the turrets, and they could then be used for gun practices instead of the main turret guns, which was much cheaper. In 1914, when the Navy abandoned this method and introduced the use of simulators, these rings were removed from the turret roofs. During the war as the defense against air attacks became more and more important, 7 cm/50 AA guns (BAG, Ballon-Abwer-Geschütz) were mounted on the turret roofs, one on each 30.5 cm twin and two on each superimposed triple.

One of the design flaws of these turrets was their extremely thin (60 mm) turret roof armor. To cap it all, on the triple turrets the cupolas for the rangefinders were extremely large and a hit on one of these could have peeled back the thin turret roof armor. In the case of the triple turrets there were unprotected slots between the gunhouses and the barbettes.⁵⁸⁷ There is a widely held view that under battle conditions the gunhouses of the triple turrets could not be ventilated as they would suck in the propellant gases and would be uninhabitable after 15 minutes due lack of oxygen. The original source of this view is the report of Linienschiffskapitän Kamillo Teuschl, commander of the *Viribus Unitis* on his ship from 1916. The report writes that under battle conditions these air vents on the Oberdeck were closed to avoid sucking in the propellant gases.⁵⁸⁸ In fact, the closing of the air vents on the Oberdeck of the turret ventilation did not mean the shutdown of the ventilation itself. The 50 cm diameter ventilation air duct ran down from the Oberdeck outside the barbette to the underside of the lowest part of the revolving stalk of the turret, joining it in the axle of rotation. This air duct had two closeable inlets, one on the Oberdeck at the base of the barbette not far from the centerline of the ship and the second inlet was one level below, on the Batteriedeck. When the inlet on the upper deck was closed by a watertight lid the system was sucking the air from this second inlet on the Batteriedeck.⁵⁸⁹ The ventilator had a 3 cubic meters per second capacity and was on the Mitteldeck, one level below the Batteriedeck. It is true that this arrangement had its drawbacks: the capacity of the ventilator was too small and under battle conditions the air sucked in was not as fresh

as would have been desirable; but it is far from true that the turrets became uninhabitable under battle conditions. In addition, in August 1916 the Navy learned from the reports of its experts who had been sent to Germany that during the Battle of Jutland/Skagerrak the German crews had remained operable by using gas masks when smoke and gases had filled their stations.⁵⁹⁰

On the 24 cm/45 twin turrets of the *Radetzky* class less information is available compared to that for the 30.5 cm twins. The interiors of the 24 cm turrets were similar to the 30.5 cm turrets. They had four flats in the rotating stalk and their main ammunition hoists ran directly from the lowest flat to the gunhouse and came up between the two guns. These turrets had only a projectile ring of 20 projectiles capacity and they had no cartridge rings. In the gunhouse there were similar loading cars and hand operated chain rammers and between the latter's nine ready-round projectiles were stowed. Naturally, as the guns themselves, every device was proportionally smaller compared to the 30.5 cm turret and the turret crew was also smaller. The rammer/loading car was operated by two men. The ramming cycle was 10 seconds. A document states that the gunhouse of a 24 cm gun turret was extremely cramped and even more cramped than the gunhouse of the 30.5 cm twin. The same document informs us that on the 24 cm turrets of the *Erzherzog Franz Ferdinand* and *Radetzky* several similar accidents occurred during gunnery practices in the first half of 1911: the recoiling gun damaged the loading car because the gun was fired before the loading car could be removed entirely from behind the gun. The principal cause of these accidents was that the gunlayers who gave the order for firing the gun did not see the loading cars and the gun crews were in a hurry because the turret crew which achieved the greatest rate of fire won prizes. In September 1911, the Navy ordered an additional NCO to each 24 cm/45 and 30.5 cm/45 gun turret to supervise the loading. From September 1911, the gunhouse of a 24 cm/45 twin turret had a crew of 13 men and the gunhouse of a 30.5 cm/45 twin turret had a crew of 17 men.⁵⁹¹

Of the 35 cm twin and triple turrets intended for the "*Improved Tegetthoff*" class battleships our knowledge is scarce. While Škoda made detailed plans for the 34.5 cm turrets in two versions, no such plans for the 35 cm turrets are available. These

34.5 cm turrets had a complicated design due to the any-angle loading requirement which was more complex than those on British battleships. Thanks to the any-angle loading system these turrets were overly large and heavy, while on the other hand poorly protected.⁵⁹² In May 1912, the MTK advised not to use the any-angle loading system and instead use a fixed-angle loading system. In June 1912, the Navy decided these ships would use a new, 35 cm caliber and that they would have a simpler, fixed loading angle. This decision made it possible to reduce the barbette diameter of the 35 cm triple turret from 11.2 m to 10.3 m. The barbette diameter of the twin turret was 8.5 m. The new turret designs, thanks to the fixed loading angle, were lighter than the 34.5 cm ones, despite having heavier, larger caliber guns and their thicker turret armor. The few plans available show that the elevation range of these guns was -4/+16 degrees. Probably the Navy intended to build these turrets with the same sort of couplings as used on the 30.5 cm triples. On the evidence of the 24,500 ton battleship plans these turrets would have had interrupted ammunition hoists and a true handling room two levels below the gunhouse. The turrets would have 5 m rangefinders but not in cupolas. Instead, they would be under the roof armor looking out through periscopes under small armored hoods.

The Austro-Hungarian Navy identified the gun turrets by Roman numerals instead of letters, which ran from fore to aft. On the *Radetzky* class the six turrets were numbered clockwise, starting from the fore 30.5 cm turret as on the German *Nassau* class. Casemates were also identified by Roman numerals.

Fire Control

A post-war American report describes the fire control system of the Austro-Hungarian battleships as: "This system was patterned after the German system but did not, as a result of the war, keep pace with the improvements made in Germany nor did it represent the latest developments of fire control as used in the German Navy. All of the apparatus described in the above report represented very obsolete apparatus as far as Germany was concerned and can therefore be only of interest from an historical point of view. [...] In all other respects the

Austrian fire control does not deserve serious consideration by the Department as the German fire control has already been submitted fully and in detail, and as the latter only, offers points for study by the Bureau for Ordnance."⁵⁹³ These lines were written by the US Naval Attaché in Berlin, W. P. Beehler in October 1922. He sent a report on Austro-Hungarian fire control to the Director of Naval Intelligence which was compiled from narrations of former Austro-Hungarian officers. The file contains also a report from February 1914, written by an US naval officer, who was allowed to see the fire control system of the *Tegetthoff*. These two American reports are among the most important sources of the fire control system of the Austro-Hungarian battleships. Friedrich Prasky in his book on the *Tegetthoff* class also deals with the fire control system in details.⁵⁹⁴ Beside these there are several documents which contain more or less information about this fire control system.

The original, pre-war fire control system of the most modern Austro-Hungarian battleships (*Radetzky* and *Tegetthoff* classes) was quite simple. On these battleships there were no plotters, plotting rooms, complex systems or sophisticated mechanical calculators. The most sophisticated elements of the Austro-Hungarian fire control system were the Barr & Stroud rangefinders and the Siemens & Halske DC communicating apparatuses (transmitters and receivers).⁵⁹⁵ The Navy made a report for internal use on the fire control, which found it very obsolete. This report suggests that the Navy may have used some simple Dumaresq-like device,⁵⁹⁶ but other sources do not confirm this.⁵⁹⁷

Each of the *Radetzky* class and the *Tegetthoff* class battleships had two main fire control stations, one in the fore and one in the aft conning tower. The ships had two "wing" control stations for the secondary battery, on the *Radetzky*s integrated into the superstructure, while the *Tegetthoffs* had free standing control towers. On each ship all four control stations had their own rangefinders. The battleships of the *Radetzky* class had four 9-foot (2,743 mm), while the units of the *Tegetthoff*-class had two 12-foot (3,658 mm) and six 9-foot Barr & Stroud rangefinders.⁵⁹⁸ On the latter class every gun turret was fitted with a rangefinder. All of the battleships of both classes had two fully equipped fire control positions which were located fore and aft under the armored deck. These were intended

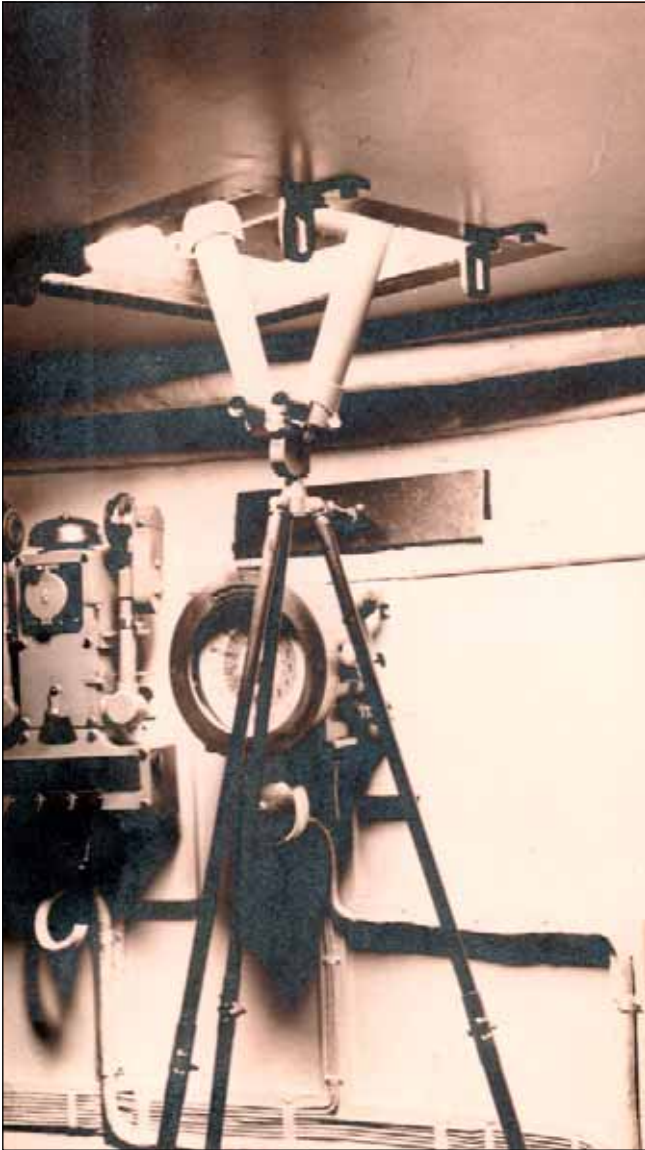

71 Inside of the main fire control position of *Viribus Unitis* in the fore conning tower. The clocklike instrument is the receiver of the firing observation communication apparatus, note the electric bell under the dial. The other instrument beside it is a telephone. In the foreground a Zeiss scissor telescope on a tripod for observing the splashes of the 30.5 cm shells

for use only in case of serious damage of the upper positions. The battleships of the *Radetzky* class also had a fire control position on the foretop.⁵⁹⁹

There were two main versions of electromechanical communication apparatus, both made by Siemens & Halske. The first one was the range and deflection communication apparatus. The transmitter for this equipment had a dial with pointers moved by cranks. This communicated the computed range and lateral deflection and it could also set the necessary corrections for things like propellant temperature, wind speed and direction, etc. In addition, there was an apparatus which communicat-

ed the type of target, the method of firing, projectile type and orders for loading. There were also red lamp signals, one for each gun, which served to notify the firing commander that the gun corresponding to the signal was ready for firing. Transmitters were in the fire control stations and the receivers in the turrets, batteries and in the other fire control stations.

The second one was the firing observation communication apparatus. The firing observation stations were in the crow's nests on the fore and main masts, 40 m above the water. Observations of the splashes were made by Zeiss "Scherenfernrohr" (scissor telescope) and monocular telescopes. There were telephones, voice pipes and transmitters of fire observation communication equipment. This equipment communicated such data as to whether the broadside fell short or otherwise, or whether the shells fell in front of the target or behind, etc. The receivers of this apparatus were in the fire control stations.⁶⁰⁰ This apparatus had also a dial with pointer, on the transmitter moved by two cranks. The receiver did not have cranks; an electric bell was installed under the dial instead, which signaled that new observation data was arriving. From 1913, in the turrets of the *Tegetthoff* class train indicators (Zielempfänger mit Backswinkelzeiger) made by the Škoda were installed.⁶⁰¹

In a nutshell this was the fire control system of the modern Austro-Hungarian battleships. The Navy was well aware of the obsolescence of this system. Anton Haus as Marinekommandant recognized the importance of modernization of the fire control system. The Austro-Hungarian Navy negotiated with Arthur Hungerford Pollen's firm, the Argo Co. in 1913 and 1914 on buying the Pollen fire control system. We know from documents that the Navy intended to equip each 24,500 ton battleships with two full sets of the Pollen system with the Argo Clock and plotter.⁶⁰² Most probably Haus wanted to equip the units of the *Tegetthoff* class the same way. However, Haus miscalculated the time available for introducing the Pollen system (he thought that the great European war would break out in 1916); by the time that the Navy ordered two Argo Clocks for 144,000 Kronen it was too late. The two clocks were paid and shipped, but they reached only Ostende when the war broke out.⁶⁰³

In August 1914, the Austro-Hungarian Navy found itself without a modern fire control system.

There was the possibility to overcome this handicap, but the Navy acted with incomprehensible slowness. Austrian engineer Ludwig von Petravic had a factory in Vienna which manufactured fire control devices. In 1914, they constructed the E-Uhr, which had similar purpose as the Vickers Range Clock. The German Navy bought many of them, but the Austro-Hungarian Navy showed no interest in it, because they were engaged in negotiations with the Argo Co. The most important product of Petravic's firm was the Ziel-Richt-Abfeuerungsgerät, a gyrostabilized electric firing system. The German Navy successfully used this device from 1916, and the Germans purchased a license in 1917 for one million Marks. Petravic put in an offer for delivery of his firing system for the *Radetzky* and the *Tegetthoff* classes in 1917. When Hungary agreed to the order on 29 October 1918, it was too late, by that time the Dual Monarchy had already lost the war.⁶⁰⁴

During the war the following improvements of the fire control system were made: The dial of the range communication apparatus was modified so that the maximum range was augmented from 15,000 m to 18,000 m. In 1915 new electromechanical train indicators were installed in the gun turrets. In 1917, the German Richtungsweiser für automatische Ziel- und Seitenverschiebung (automatic direction indicator for target bearing and deflection) was installed on the *Tegetthoff* class. The transmitter was a scissor telescope installed on the roof of the fore fire control station. The telescope was directed to the target by a crank, and by a second crank the deflection was set. The receivers in the gun turrets operated on the "follow the pointer" principle. The equipment automatically corrected for the parallax arising from the distance of the individual turrets from the telescope.⁶⁰⁵

The American report describes ranging fire as follows: For the *Radetzky* and *Tegetthoff* classes salvo fire of four shells was systematized. The salvo fire with one shot per turret had the advantage of economizing ammunition and also prevented dis-



72 Inside one of the fire control positions of the 15 cm/50 battery

tortion of the weak hull structure during firing. The firing cycle was between 20 and 40 seconds. The straddle process was used in preliminary fire. The first large fork was 1/10 of the firing distance. After this the fork was continuously reduced by half until the target was covered.⁶⁰⁶

The American report describes the theoretical operation of the fire control of the modern Austro-Hungarian battleships. Theoretical, because Austro-Hungarian battleships never fired their guns on an enemy ship only on land targets during the war.

"In firing at an enemy target, the procedure was as follows: When an enemy unit or fleet division came in sight, the commander of the ship would order the I Artillery Officer to begin firing. He took the bearings of the target in question [...] He communicated this bearing along with the exact description of the target,⁶⁰⁷ to the rangefinder installed in the lantern turret. The direction of the target communicated to the rangefinder was transmitted electrically to the indicator showing the angle at which the gun is trained.

This apparatus installed on the scale or base of the rangefinder show the direction by means of an

indicator moving on a graded scale, the direction of the target to the middle line. Similar receiving apparatus in all the other commanding stations and gun turrets serve to communicate the direction of the target to this apparatus. If the guns were trained in the direction commanded, then control indicators operate on the several apparatus in all the commanding stations, at the given adjustment and the firing commander was therefore informed regarding the correct position of his turret. [...]

The distance or range was computed and communicated every half minute to the officer in the commanding station who registered same on a coordinate system and took the average. In this way, the firing commander was informed of a fairly average range and at the same time of the daily ballistic corrections of the rangefinder in his commanding station. [...]

While approaching the firing distance, the orders regarding to the method of firing, character of shell, and the command to "load", were given by means of speaking tubes and other apparatus. The guns were elevated corresponding to the maximum firing distance.

For constructive reasons, the maximum firing distances in the heavy guns were standardized to 26,000 meters.⁶⁰⁸

By means of the continuous statistics regarding range, the firing commander always had some definite point to go on relative to the approach of and lateral deflection of the target, and could communicate his orders to the turrets in connection with the range and lateral deflection.

Just as soon as the guns were loaded and directed according to orders, red lights appeared at the commander's station, which informed the firing commander when each gun was ready for action.

The order to open fire was given by the ship's commander, upon the report of the gunnery officer. Before the firing of each salvo, the order »attention« was sent to all turrets and batteries by means of the speaking tubes.

As soon as the correct firing range was reached, the firing commander pressed a key and a loud bell sounded in all the turrets. At this signal, the chief

gunner of the guns in question fired either mechanically by hand or through the operation of an electrical key. [...]

The firing now took place as described in the beginning and as soon as the firing director officer, assisted by the firing observer in the crow's nest, recognized or received information that the target was covered, the information necessary for the effective firing was given. For this purpose, the data of the rangefinder, the elevations ordered, the reports of the firing observer and the course were all indicated on a coordinate system. The end points of the ordinates gave curves from which the daily ballistic corrections of the gun batteries could be seen, on the basis of which the orders for the following salvos were given. As this table was to be found in the gunnery commander's station, no complicated work was necessary and it only required a glance on the part of the firing commander to inform himself perfectly regarding the orders to be given. This method of fire control seems a little bit old-fashioned, it is true, but it always sufficed for the Austro-Hungarian Navy as the successes in practice and war amply testified. Drill and iron consistency in the training of officers and men, frequent practice, the practical eye of the firing commander and principally the firing observer, made up for the deficiency in apparatus. The weather and other conditions in the Adriatic also played an important part.⁶⁰⁹

The last statements of the report quoted above seem a bit exaggerated. In fact, war experience never proved the success of the fire control system of the main battery of the modern Austro-Hungarian battleships, since it was never deployed in combat situation. The report on the 30.5 cm gunnery trial of the *Szent István* contradicts the alleged "drill and iron consistency". During the trial, despite all the efforts of the first gunnery officer, the fire control system failed, mainly due to the inexperience of the badly trained personnel.⁶¹⁰ The economizing so characteristic of the Navy, insufficient practice, the lack of officers and educated men and other factors during the war, all raised serious doubts about the efficiency of the fire control system of the Austro-Hungarian battleships.

EPILOGUE

Íme, hát megeltem hazámat.
a földet, ahol nevemet
hibátlanul írják fölébem,
ha eltemet, ki eltemet.

E föld befogad, mint a persely.
Mert nem kell (mily sajnálatos!)
a háborúból visszamaradt
húszfilléres, a vashatos.

*József Attila*⁶¹¹

The year 1904 was a milestone in the history of the Austro-Hungarian Navy. Several important symbolic events occurred that year. The first was the extraordinary credit that was voted for the Navy. Thanks to this credit, for the first time in its history, the Navy's budget exceeded ten percent of the armed force's total budget. In September 1904, the Österreichische Flottenverein (Austrian Navy League) was established following the example of the successful German Flottenverein. Over the next ten years the membership of the Austrian Flottenverein increased by a thousand times. The strength of the Flottenverein was not only the dynamically growing number of members, but also in the advocacy capacity of the joining politicians and industrialists. Among the external factors the outbreak of the Russo-Japanese War had a decisive role. The successful Japanese raid on Port Arthur fundamentally questioned the Austro-Hungarian doctrine of "pure coastal defense," and the reviving Italian threat was more imminent than since 1866. Last, but not least that is when the Navy decided to make a qualitative leap in battleship construction. This intention marked a break with the doctrine of "pure coastal defense."

The story told by this book also began in 1904. Design works were started in that year on the first "dreadnought" battleships which were officially designated as *battleship* (Schlachtschiff) and which later became the *Radetzky* class. The next ten years were characterized by intensive development of the Austro-Hungarian fleet. During this period the Navy's budget nearly tripled and the proportion of the naval budget's share of the armed force's to-

tal budget reached 25 percent. Between December 1906 and May 1914, the delegations voted the expenses of three battleship classes with a total value of 688.6 million Kronen. The total price of the seven battleships actually built was 360.4 million Kronen. The Austro-Hungarian Navy spent 891.6 million Kronen on ship construction, repair and naval artillery between 1900 and 1914, the price of the last two battleships classes totaled up to 40 percent of this amount.

Already at the time of the construction of these battleships the question was raised: would the Dual Monarchy need these ships? Since the end of the World War I this question has been raised time and again. The other frequently asked question is: was the Austro-Hungarian fleet a "luxury fleet," as Winston Churchill labeled the Imperial German Navy? The answers to these questions are not as obvious as many people may think. True, if one looks at the history of the war and at the role of the Austro-Hungarian capital ships which spent almost the entire war moored idly in their naval bases, one can easily come to the conclusion that building these battleships was a tremendous waste of money. However, it should be taken into account that the development of an army or a navy is determined by the experiences of the wars of the past and by the trends of the present, and not by the expectations of the future. It is unfair to call the Navy to account for not taking into account the experiences of 1914-1918 in 1911. In 1911, both past experiences and current trends suggested that the Dual Monarchy should build dreadnought battleships.

Compared to the ideology and propaganda behind the German naval buildup, the reasons for the Austro-Hungarian fleet development were more realistic: the Italian threat to Austria-Hungary was much less imaginary than the British threat to Germany. The defining experience of the Austro-Hungarian Navy and the cornerstone of the naval thinking was the Battle of Lissa of 1866. The Austro-Hungarian Navy's primary task was fighting a local war with the Italian Navy and in 1914 it would have had a much better chance against the

Italian fleet than the German Navy had against the Royal Navy. Unluckily, in August 1914 the Austro-Hungarian Navy found itself in a global war instead of a local war and had to face the combined naval forces of France and Britain. The situation became even worse, when in May 1915 Italy declared war on Austria-Hungary.

The Austro-Hungarian Monarchy had the lowest per capita military spending of any of the European Great Powers excluding Russia. Some calculations suggest that Austro-Hungarian military spending per capita when adjusted for purchasing power was considerably below the level of Russia. The proportion of the Dual Monarchy's naval budget's share of the armed force's total budget was the second lowest among the European Great Powers, this share was the lowest again in Russia. These figures do not suggest that the Austro-Hungarian naval buildup in the last decade prior to 1914 would have exceeded the Empire's financial burden-bearing capacity. This naval buildup and the rise of the naval budget seemed only to be so enormous because it started from a very low level. It should be noted that this development was aimed at countering a real threat, unlike the German naval buildup.

After the lost war several army generals of the former Empire were complaining in their memoirs about the prewar "Fleet folly". These generals did not understand the true nature of navalism. They did not realize that in the age of navalism armies often did not share the same popularity as the navies. This was especially true for the Dual Monarchy. In Austria the South Slavs and the Czechs supported the development of the Navy while in the case of the common Army they were much less enthusiastic. In Hungary the common Army was the symbol of the Habsburg oppression while the Navy was regarded as a distant, exotic and Austrian matter. Because the Navy was less of a symbol of oppression it was easier to find a way to sway the thinking of the Hungarian political elite. They were converted to the cause of the Navy through their pockets. On the other hand, the postwar laments of generals were not entirely true. The new Army Service Law of 1912 (*Kriegsleitungsgesetze* in Austria and *Véderőtörvény* in Hungary) significantly increased the number of the yearly contingent of the new recruits and also in 1912 the delegations voted a 250 million Kronen

extraordinary credit for the Army. This credit enabled the long needed modernization of the Army artillery. The only problem was that a fraction of this modernization program was implemented until 1914. Blaming only the development of the Navy for the shortcomings in the development of the Army seems to be a bit unjust and similar statements do not fully live up to the facts.

Looking at the history of the Austro-Hungarian naval buildup between 1904 and 1914, there may be many criticism of it. First, there is the question of how the budget was spent effectively. Compared to the British and German prices the Austro-Hungarian Navy had to pay a price 20 percent higher for almost every item. The Navy was forced to order items from the more expensive domestic industry because it was the only way to secure the voting of its budget. The Navy's attempts to break down the prices of the Austrian naval industry regularly failed. Involvement of the Hungarian industry in the warship building did not resolve this problem because it was a result of a political deal, and the Hungarians tried to ask for even higher prices. The other problem was the asymmetry of the development of the fleet. The absolute priority of the battleship construction resulted in that there were not enough funds in the naval budget for the smaller vessels. These were badly missed during the war especially the lack of the modern destroyers and submarines. This asymmetry is perfectly reflected in the fact that while in 1914 Italy had only a modest superiority in modern battleships over the Dual Monarchy the Italian Navy's superiority in destroyers, torpedo boats and submarines was twofold over the Austro-Hungarian Navy. Last, it has to be mentioned that the two battleship classes built after 1904 while more expensive compared to the Western ships suffered from many design flaws. The armament of the *Radetzky* class battleships, thanks to the pressure from the Marinekommandant Admiral Montecuccoli, was obsolete even on the drawing board. The *Tegetthoff* class battleships, primarily thanks also to Montecuccoli and the artificial weight limit of 20,000 tons were too small for the amount of weapons carried. This caused stability problems and a weak hull structure thanks to the weight savings needed to accommodate four triple turrets on a small ship. The torpedo protection system of both classes was flawed as its design was based purely upon useless theoretical

calculations. It is incomprehensible why the Navy accepted the flawed design for the dreadnoughts in late 1909 while from May 1909 they knew the results of the German underwater explosion tests which, had they been used, would have eliminated these flaws.

Through the expansion of the Navy and the construction of its *real* battleships, especially the four dreadnoughts, Austria-Hungary secured a full membership in the club of the great powers. In the age of the navalism, especially after the revival of the Italian threat in 1902, the Dual Monarchy had to build battleships in order to deter Italy at sea. The memory of the Battle of Lissa was still vivid on both sides. Without its dreadnoughts Austria-Hungary would not have been a strategic factor in the Mediterranean on the eve of the World War I.

As was mentioned previously, the Habsburg Empire's navy was primarily developed for fighting a local war with Italy. In August 1914, the Austro-Hungarian Navy, the eighth largest navy of the world, found itself in a global war and was gradually confronted with the first and the third to seventh largest navies of the world. From 1917, aside the

Italian, British and French units already present, Japanese and American warships also appeared on the Adriatic. Without the prewar naval build-up especially the dreadnoughts and the submarines even securing the Empire's long Adriatic coastline would have been endangered. The only things that kept these forces from invading the Empire were the fear of the lethal torpedoes of the submarines and of the Austro-Hungarian dreadnoughts. Together they deterred every large scale Allied naval operation on the Adriatic and the Empire's Adriatic frontier was never really endangered until October 1918.

As the Adriatic was a secondary theater, the Allied naval commanders, considering the possible gains and losses followed a cautious policy and especially after the summer of 1915 they kept off their large, armored units out of the Adriatic. The largest units of the Austro-Hungarian Navy spent almost the entire war at Pola in inactivity, but their "fleet in being" status posed an active threat throughout the war. The Empire's navy and its newest battleships tied down a part of the naval power of the Allies, warships that could have been better used elsewhere.

APPENDIX

Austro-Hungarian Naval Ranks in 1914 in German, Croatian, Italian and Hungarian and their Contemporary British Equivalents

Admirals

<i>German</i>	<i>Croatian</i>	<i>Italian</i>	<i>Hungarian</i>	<i>British RN</i>
Großadmiral ⁶¹²	veliki admiral	grande ammiraglio	vezértengernagy	Admiral of the Fleet
Admiral	admiral	ammiraglio	tengernagy	Admiral
Vizeadmiral	viceadmiral	viceammiraglio	altengernagy	Vice-admiral
Kontreadmiral	kontraadmiral	contraammiraglio	ellentengernagy	Rear-admiral

Senior Officers

<i>German</i>	<i>Croatian</i>	<i>Italian</i>	<i>Hungarian</i>	<i>British RN</i>
Linienschiffskapitän	kapetan bojnog broda	capitano di vascello	sorhajókapitány	Captain
Fregattenkapitän	kapetan fregate	capitano di fregatta	fregattkapitány	Commander
Korvettenkapitän	kapetan korvete	capitano di corvetta	korvettkapitány	Lieutenant-commander

Junior Officers

<i>German</i>	<i>Croatian</i>	<i>Italian</i>	<i>Hungarian</i>	<i>British RN</i>
Linienschiffsleutnant	poručnik bojnog broda	tenente di vascello	sorhajóhadnagy	Lieutenant
Fregattenleutnant	poručnik fregate	tenente di fregatta	fregatthadnagy	Sub-lieutenant
Korvettenleutnant ⁶¹³	poručnik korvete	tenente di corvetta	korvetthadnagy	–

Engineers

Oberster Ingenieur (Kontreadmiral)

Oberingenieur 1. Klasse (Linienschiffskapitän)

Oberingenieur 2. Klasse (Fregattenkapitän)

Oberingenieur 3. Klasse (Korvettenkapitän)

Ingenieur 1. Klasse (Linienschiffsleutnant)

Ingenieur 2. Klasse (Fregattenleutnant)

Ingenieur 3. Klasse (Korvettenleutnant)

Machinists

Ober-Maschinebetriebsleiter 1. Klasse

Ober-Maschinebetriebsleiter 2. Klasse

Maschinebetriebsleiter 1. Klasse

Maschinebetriebsleiter 2. Klasse

AUSTRO-HUNGARIAN DECK DESIGNATIONS

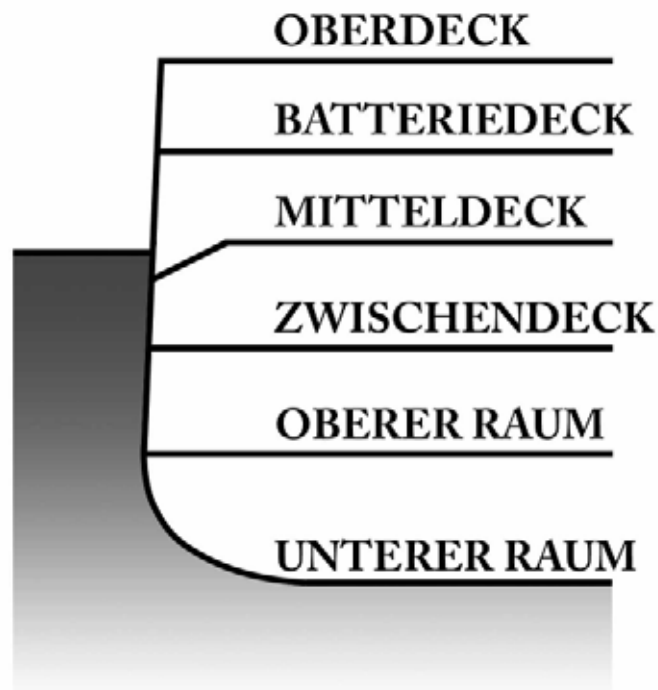

RADETZKY & TEGETHOFF
CLASS

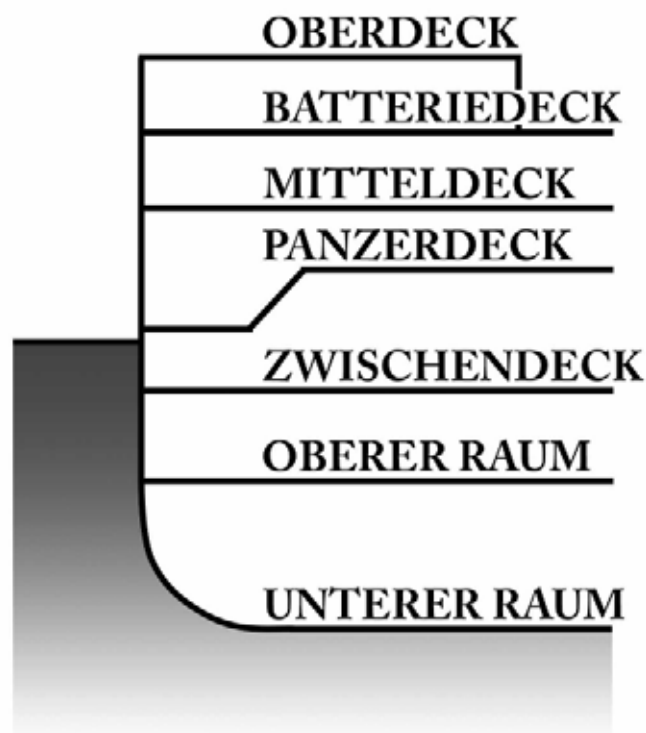

IMPROVED TEGETHOFF
CLASS

Abbreviations

- KA – Österreichisches Staatsarchiv, Kriegsarchiv, Wien
MS/PK – Marinesektion/Präsidialkanzlei
MS/II GG – Marinesektion/II Geschäftsgruppe
MS/OK – Marinesektion/Operationskanzlei
MKSM – Militärkanzlei Seiner Majestät
MMKMA – Magyar Műszaki és Közlekedési Múzeum Archivuma, Budapest
MNL OL – Magyar Nemzeti Levéltár Országos Levéltára, Budapest
NA – National Archives, United States
ONI – Office of Naval Intelligence
GMR – Die Protokolle des gemeinsamen Ministerrates des österreichisch-ungarischen Monarchie 1896-1907. Budapest, 1991.
StPD – Stenographische Sitzungsprotokolle der Delegation des Reichsrates

Közösügyi bizottság – A közösügyek tárgyalására a Magyar Országgyűlés által kiküldött bizottság jegyzőkönyvei, irományai, naplója (Hungarian delegation)

Contemporary Periodicals, Tracts and Reference Works

- A cs. és kir. haditengerészet jelentése az ... évről
A Magyar Szent Korona országainak költségvetése az ... évre
Arbeiter Zeitung
A Tenger
Magyar Figyelő
Militärstatistische Jahrbuch
Neue Freie Presse
Rangs- und Eintheilungsliste der k. u. k. Kriegsmarine

Endnotes

- 1 Halpern, Paul G. *The Mediterranean Naval Situation* Cambridge 1971, p. 150.
- 2 The common Council of Ministers usually was presided by the Emperor, beside the common ministers both prime ministers and finance ministers were stationary members.
- 3 Walter Wagner: *Die obersten Behörden der k. (und) k. Kriegsmarine 1856-1918*, Wien, 1961, (Wagner) p. 49-61.
- 4 Dalmatia today is part of the Republic of Croatia, while in the Dual Monarchy Croatia with a relative short coastline was part of Hungary, and Dalmatia and Istria were parts of Austria.
- 5 *Militärstatistisches Jahrbuch 1887*
- 6 A cs. és kir. haditengerészet jelentése az 1913. évről, p. 107.
- 7 *Militärstatistisches Jahrbuch 1910*
- 8 See Gonda Béla: *Haditengerészetünk és a magyarság*. In: *A Tenger 1913/9*
- 9 Leo Reiter: *Die Entwicklung der k. u. k. Flotte und die Delegationen des Reichsrates*, Ph. D. dissertation, Wien 1948, p. 18-20. The official currency of the Dual Monarchy was Gulden (forint) until 1892. In 1892 it was introduced the new currency, named Krone (korona, 1 Gulden=2 Kronen). One British Pound was equivalent of about 24-25 Kronen, and one German Reichsmark was equivalent of 1.45 Kronen.
- 10 Allegedly Pöck, who was at that time in Vienna, had a burst of anger hearing the news of Tegetthoff's victory at Lissa.
- 11 Maximilian Daublebsky von Sterneck: *Erinnerungen aus den Jahren 1847-1897*, Budapest-Leipzig, 1901, p. 209.
- 12 Lawrence Sondhaus: *The Naval Policy of Austria-Hungary 1867-1918*, West Lafayette, 1994, p. 56.
- 13 *Jeune École* was a strategic naval concept developed during the 1870-1880s. It advocated a great number of small, powerfully equipped fast units to combat a battleship fleet, or commerce raiders capable of ending the trade of the rival nation. The leader of the *Jeune École* was French admiral Aube. As in any navy, in these years there were heated debates in the Austro-Hungarian Navy over the *Jeune École*. The opponents of the *Jeune École* named the new unarmored cruisers of the navy „Sterneck's sardine boxes”.
- 14 Sondhaus p. 101.

- 15 Lothar Höbelt: Die Marine, In: Die Habsburgermonarchie V. Band, Die bewaffnete Macht, p. 709.
- 16 For example under Sterneck the Navy sponsored generously the scientific research (Red Sea expeditions), while Spaun not allowed more scientific expeditions.
- 17 Reiter pp. 105-106.
- 18 Közösügyi Bizottság 1898, napló pp. 25-26.
- 19 Árpád was the head of the confederation of Hungarian tribes at the turn of the 9th and 10th centuries. The dynasty descending from Árpád ruled the Kingdom of Hungary until 1301.
- 20 KA MS/PK XV-7/3 2464 ex 1898
- 21 The extraordinary credit (ausserordentliches Kredit) was in fact not credit at all, but a non-repayable grant. It was a technical term applied to the funds voted for special development projects above the normal budget.
- 22 Sondhaus p. 179.
- 23 StPD XLI/I 1906 p. 465.
- 24 KA MS/PK XV-7/9 108 ex 1908
- 25 Wagner p. 87. ; Paul G. Halpern: Anton Haus. Österreich-Ungarns Großadmiral. Graz 1998 (Halpern 1998) pp. 85-86.
- 26 Sondhaus p. 56.
- 27 On 30 June 1902, only two days after the renewal the Triple Alliance Italian and French foreign ministers Prinetti and Barrère signed a secret agreement pledging that Italy would remain neutral in any conflict to which the French entry had been “provoked”.
- 28 Sondhaus p. 157
- 29 Wolfgang Foerster: Die deutsch-italianische Militärkonvention. In: Die Kriegsschuldfrage Vol. 5 (1927) Issue 5 pp. 400-401.
- 30 Halpern 1971 p. 228.
- 31 Halpern 1998 pp. 79-80. The first reaction of Haus was: „Alles recht und schön, aber wie bekommen wir unsere Kohle?“ (All right, but how do we get our coal?)
- 32 Halpern 1971 pp. 244-246.
- 33 Halpern 1971 pp. 252-255.
- 34 Halpern 1998 p. 130.
- 35 Erich Krenslehner: Die k. u. k. Kriegsmarine als wirtschaftliche Faktor 1874-1914. Ph. D. Dissertation, Wien, 1972 (Krenslehner) p. 24.
- 36 StPD XXVII session p. 137.
- 37 Reiter pp. 115-116.
- 38 Sondhaus p. 149.
- 39 The Danubius of Budapest built river warships for the Navy before 1906. On the political background and the orders see: Mihály Krámlí: Naval Shipbuilding in the Danubius Shipyard in Rijeka 1906-1915. In: Proceedings of the 3rd International Conference on the Preservation of the Industrial heritage in Rijeka (ed. Miljenko Smokvina). Rijeka, 2010. pp. 655-671.
- 40 KA MS/PK XI-4/9 2157 ex 1914. See also: Krámlí Mihály: A győri Magyar Ágyúgyár Rt. felállítása 1911-1914. In: Hadörténelmi Közlemények 2010/4 pp. 1005-1014.
- 41 Krenslehner p. 24.
- 42 The Pola Arsenal had its own shipyard but its main profile was ship repair and maintenance. The largest ship built at the Pola Arsenal was the 7,200 ton armoured cruiser *Sankt Georg*. The slipways of this shipyard were too small to build battleships.
- 43 Siegfried Popper was born in Prague in 1848. He was the highest ranking Jew in the history of the Austro-Hungarian Navy. He gained a degree in mechanical engineering at the Karlsruhe Institute of Technology. In 1871 he joined the Navy as a naval architect. In 1902 he was promoted to chief naval architect (Obere Schiffsbauingenieur) of the Austro-Hungarian Navy. In April 1904 he held the ad personam created rank of Generalschiffbauingenieur, which was equivalent to the rank of Kontreadmiral. In 1907 Popper retired from the Navy and worked for the STT as consultant until 1913. In 1917 he was granted a Honorary Doctorate by the Technical University of Vienna. This was returned by the University in 1930, when Numerus Clausus was introduced. He died in Prague in 1933 he was hit by a streetcar. KA Marine Qualliste carton 4352
- 44 Christoph Ramoser: K. u. k. Schlachtschiffe in der Adria. Österreich-Ungarns Tegetthoff-Klasse. Wien, 1998 (Ramoser) p. 29.
- 45 The Marinetechnische Komitee (MTK) was an office of the Austro-Hungarian Navy in Pola. It had eight departments. Among other technical matters the MTK was responsible for providing warship designs to the Navy.
- 46 Ramoser p. 30.

- 47 MMKMA Mladiata-collection carton 13
“Alternativ Projekte für ein Schlachtschiff
12,000-13,000 T”
- 48 In fact, the cases of the Škoda 30.5 cm/45 guns
were even heavier they weighed 68-69 kg.
- 49 KA MS/PK I-4/9 480 ex 1905
- 50 Ramoser p. 31.
- 51 KA MS/PK I-4/9 2482 ex 1905. The original
13,000 tons was modified to 13,500 tons in
the text.
- 52 KA MS/PK I-4/9 2667 ex 1905
- 53 In December 1903, the German Emper-
or, Wilhelm II ordered the Reichsmarineam-
t to elaborate the design for the 13,000 ton
future battleship class armed with 4×28 cm
and 8×21 cm guns. Their construction would
have started in 1906. In 1904, Konteradmi-
ral von Eickstedt proposed Tirpitz to build
instead battleships of 16-18,000 tons armed
with 10-12 heavy guns, because the British
presumably would build similar battleships.
In February 1905, the German naval attaché
in London reported that the displacement of
the next British battleship would be at least
18,000 tons. This news from London forced
the Germans to redesign their future battle-
ship. In March 1905, the Reichsmarineamt
presented four designs to the Emperor, all
with an 8×28 cm main battery. On 18 March,
Wilhelm II approved the 15,700 ton design.
In June 1905, it turned out that the new Brit-
ish battleship would have a 10×30.5 cm main
battery. After a few months of hesitation, in
September 1905 Tirpitz ordered to elabo-
rate the design for an 18,000 ton battleship
with 12×28 cm armament. Tirpitz’s hesita-
tion was understandable, because building
battleships larger than the 16,000 tons forced
the Germans to widen the Kiel Canal (Kai-
ser Wilhelm-Kanal). The width of the canal
was increased between 1907 and 1914. Axel
Grißmer: *Linienfahrzeuge der Kaiserlichen
Marine 1906-1918*. Bonn, 1999 (Grißmer)
pp. 19-26.
- 54 KA MS/PK I-4/9 2667 ex 1905
- 55 KA MS/PK I-4/9 2667 ex 1905
- 56 KA MS/PK I-4/9 2667 ex 1905
- 57 KA MS/PK I-4/9 2667 ex 1905
- 58 KA MS/PK I-4/9 2667 ex 1905
- 59 KA MS/PK I-4/9 2667 ex 1905
- 60 KA MS/PK I-4/9 2667 ex 1905
- 61 KA MS/PK I-4/9 3299 ex 1905
- 62 MMKMA Mladiata-collection carton 13
“14,000 T Schlachtschiff”
- 63 KA MS/PK I-4/9 2667 ex 1905
- 64 Baumgartner-Pawlik-Sieche: *Die Radetzky
Klasse*. Graz, 1984 p. 5. The 10 kg charges
were the 1/10 scale representations of 100 kg
naval mines. The first test was a complete fail,
the charge did not explode.
- 65 MMKMA Mladiáta-collection carton 1
„Gewichtsrechnung S. M. S. Radetzky”, „Ge-
wichtsrechnung S. M. S. Erzherzog Karl”
- 66 *Erzherzog Franz Ferdinand* was commis-
sioned a year before the first German *Helgo-
land* class battleship.
- 67 KA MS/PK I-4/9 2667 ex 1905
- 68 MMKMA Mladiáta-collection carton 1
“Gewichtsrechnung S. M. S. Radetzky”
- 69 MMKMA Mladiáta-collection carton 1
“Gewichtsrechnung S. M. S. Radetzky”
- 70 From the early 1900s the Navy preferred bri-
quette over coal. The main advantage of the
briquette was that there was no need to break
it into smaller pieces in the boiler room.
- 71 Nikolaus A. Sifferlinger: *SANKT GEORG.
Österreich-Ungarns letzter Panzerkreuzer im
Dienste der k. u. k. Außenpolitik in Krieg und
Frieden*. Wien, Graz, 2003 (Sifferlinger) p. 19.
- 72 Despite the armored cruisers were represent-
ing a new type of ship, the Navy continued
to use the old designation *Rammkreuzer*. So
the two 4,000 ton unarmored cruisers were
Rammkreuzer A and *B* and the first armored
cruiser *Rammkreuzer C*.
- 73 Austria-Hungary had the eighth largest Navy
and the tenth largest merchant fleet in the
World. To be fully informed about the real im-
portance of the Austro-Hungarian merchant
navy it should be know that the Dual Monar-
chy’s Danube merchant fleet had greater cargo
capacity than its seagoing merchant fleet.
- 74 KA MS/PK I-4/9 2667 ex 1905
- 75 KA MS/PK I-4/9 2667 ex 1905. The design
A had 160 mm, the others had 150 mm thick
belt armor.
- 76 KA MS/PK I-4/9 2667 ex 1905
- 77 KA MS/PK I-4/9 2667 ex 1905
- 78 KA MS/PK I-4/9 3299 ex 1905
- 79 KA MS/PK I-4/11 1434 ex 1905

- 80 KA MS/PK I-4/4 565 ex 1908
81 KA MS/PK I-4/4 565 ex 1908
82 KA MS/PK I-4/11 1434 ex 1905
83 KA MS/PK I-4/11 1434 ex 1905
84 In the Hungarian parliament the opposition frequently applied the so called obstruction (filibustering). When István Tisza became prime minister he was determined to crack down the protests of the opposition. He insisted on a change in house rules in order to deal with the obstruction. On 18 November 1904 a representative of the governing party submitted a motion to change the house rules. During the following commotation the President of the House of Representatives suddenly declared that the proposal had been adopted and the session was suspended. Allegedly the President silently called for the proposal to be voted on waving a handkerchief. On the next day the opposition parties entered into an alliance.
- 85 StPD XLI p. 461.
86 Közösügyi bizottság 1906 II napló p. 124-137.
87 StPD XLI/I p. 1177. At that time Lajos Kossuth's son Ferenc Kossuth was the Commerce minister of the Wekerle government, and a Hungarian merchant ship was named after him.
- 88 KA MS/PK I-4/1 2140 ex 1908
89 KA MS/PK I-4/1 2140 ex 1908
90 StPD XLII p. 948.
91 The memorandum quotes a much earlier proposal which contains the following names: *Admiral Sterneck, Daun, Montecuccoli*. The writer of the memorandum adds that these names cannot rival such popular names as *Radetzky, Prinz Eugen* or *Laudon*.
- 92 From the 1890s it was the policy of the Navy to give a Hungarian name to one unit of every battleship class. The preceding class was an exception, because every ship was named after a Habsburg Archduke.
- 93 KA MS/PK I-4/4 565 ex 1908
94 KA MS/PK I-4/4 565 ex 1908
95 KA MS/PK I-4/4 856 ex 1908
96 KA MS/PK I-4/4 866 ex 1908
97 Infanta Maria Theresa of Portugal (Bragança) was the second daughter of Miguel I of Portugal. She was the third wife of Archduke Karl Ludwig von Österreich, younger brother of Emperor Franz Joseph. With this marriage she became the stepmother of Archduke Franz Ferdinand. She was the sponsor (Taufpatin) of the dreadnought *Szent István* in January 1914.
- 98 Sondhaus p. 183., Halpern 1971 p. 190.
99 KA MS/PK I-4/1 2140 ex 1908
100 KA MS/PK I-4/1 3016 ex1908
101 Because Hungarian industry was less developed than Austrian-Czech industry, a compensation scheme was very important part of this agreement. Because the Navy ordered all the battleships from the Austrian STT the shipyard had to order one third of the steel material for these ships from the Hungarian iron industry.
- 102 KA MS/PK I-4/1 3043 ex 1908
103 KA MS/PK I-4/1 3043 ex 1908
104 KA MS/PK XV-7/9 108 ex 1908
105 KA MS/II GG 47C/15 2 ex 1908
106 KA MS/II GG 47C/15 2 ex 1908
107 KA MS/II GG 47C/15 2 ex 1908
108 KA MS/II GG 47C/15 3 ex 1908
109 KA MS/II GG 47C/15 5 ex 1908
110 KA MS/II GG 47C/15 6 ex 1908
111 KA MS/II GG 47C/15 8 ex 1908
112 KA MS/II GG 47C/15 9 ex 1908
113 KA MS/II GG 47C/13 38 ex 1909
114 KA MS/II GG 47C/13 2 ex 1909
115 KA MS/II GG 47C/13 39 ex 1909
116 KA MS/II GG 47C/13 39 ex 1909
117 KA MS/II GG 47C/13 38 ex 1909
118 KA MS/II GG 47C/13 6 ex 1909 Even the Bezirkskommando of Trieste tried to “spy” on the STT knowing that the Parsons had sent a complete plan of a 25,000 HP steam turbine machinery to the shipyard.
- 119 KA MS/II GG 47C/13 40 ex 1909
120 KA MS/II GG 47C/13 5 ex 1909
121 KA MS/II GG 47C/13 42 ex 1909
122 KA MS/PK I-4/9 1382 ex 1909
123 Denn Österreich lag einst a.m. Meer. Das Leben von Admirals Alfred von Koudelka. Graz, 1987 (Koudelka) pp. 116-117.
124 As Tirpitz said: “Better is a ship afloat with five guns than a sunken one with fifty.” KA MS/PK I-4/9 1632 ex 1909
125 A few years later, after Admiral Fisher's departure from the Admiralty, the British copied German practice and started using 6-inch

- guns for their capital ships' secondary batteries (*Iron Duke* class).
- 126 Probably this model inspired the 1/25 scale cutaway model of the *Viribus Unitis* made by a team of workers of the STT yard who were also the builders of the original ship. The German model was destroyed in the Second World War while the Austrian one survived and today is on display at the Heeresgeschichtliches Museum, Vienna.
- 127 KA MS/PK I-4/9 1632 ex 1909
- 128 KA MS/PK I-4/9 1632 ex 1909
- 129 KA MS/PK I-4/9 1632 ex 1909
- 130 KA MS/PK I-4/9 1632 ex 1909
- 131 KA MS/PK I-4/9 1632 ex 1909
- 132 KA MS/II GG 47C/13 42 ex 1909
- 133 KA MS/II GG 47C/13 39 ex 1909
- 134 Koudelka p. 117.
- 135 Rüdiger Schiel: Die vergessene Partnerschaft. Kaiserliche Marine und k. u. k. Kriegsmarine 1871-1914. Bochum, 2014 (Schiel) pp. 203-205.
- 136 KA MS/II GG 47C/13 44 ex 1909
- 137 Friedrich Prasky: Die Tegetthoff-Klasse, Wien, 2000 (Prasky) p. 65.
- 138 KA MS/II GG 47C/13 7 ex 1909
- 139 *Kofferdamm* is a void space between two watertight bulkheads, its purpose is the better separation of two compartments.
- 140 KA MS/II GG 47C/13 7 ex 1909
- 141 KA MS/PK I-4/9 1632 ex 1909
- 142 KA MS/II GG 47C/13 43 ex 1909
- 143 KA MS/II GG 47C/13 43 ex 1909
- 144 The calculated turret weight per gun was 205 tons of the design D while it was 235 tons of the design C.
- 145 KA MS/II GG 47C/13 44 ex 1909
- 146 KA MS/II GG 47C/13 44 ex 1909
- 147 KA MS/II GG 47C/13 12 ex 1909
- 148 KA MS/II GG 47C/13 18 ex 1909
- 149 Ramoser p. 71. MMKMA Mladiáta-collection carton 13 "Projekt Pitzinger"
- 150 KA MS/PK I-4/9 4572 ex 1909
- 151 KA MS K. u. K. Marinetechnisches Komitee Res. Nro. 2935/I. ex 1909
- 152 KA MS/PK I-4/9 4719 ex 1909
- 153 KA MS/PK I-4/9 4289, 4596 ex 1909
- 154 Because the coupling device limited the maximum elevation of the guns to 16 and 15.5 degrees, the maximum range of the two outer guns was 19,000 m when they were not coupled together. The original range of these guns with 5 crh projectiles at 20 degrees was 22,000 m.
- 155 Dr. Balogh Tamás: Jelentés a „Szent István” csatahajónál 2008. szeptember 30. és október 5. között lefolyt expedíció eredményeiről. 2008.
- 156 KA MS/II. GG 47 C/2 12 ex 1912
- 157 MMKMA Mladiáta-collection carton 27 "Caisson Versuhe"
- 158 StPD XLI/I 1906 p. 465.
- 159 Koudelka pp. 113-114.
- 160 KA MS/PK XV-7/9 108 ex 1908
- 161 KA MS/PK XV-7/9 838 ex 1908
- 162 "Die Flagge" 1908/11 p. 1.
- 163 "Die Flagge" 1909/2 p. 1.
- 164 Rapidkreuzer: this was the official term for the 3,500 ton scouts of the *Helgoland* class.
- 165 StPD XLIII. 1908 pp. 611-613. Biankini found deterring that Montecuccoli had quoted from Kossuth before the Hungarian delegation. Biankini told Montecuccoli: "Hungarians will never be a seafaring people but they are dreaming of sea power from thousand years. They can buy anything but the spirit of seamanship the real sailors. [...] The Commander of the Navy can only give this advice: *Hungarians! The sea is not for you go to the puszta! The sea is of the Croatsians!*" (Biankini told the sentences in italics in Hungarian: „Magyarok! A tenger nem nektek való, menjetek a pusztába! A tenger a horvátoké!”)
- 166 Ramoser pp. 51-53.
- 167 Sondhaus p. 197.
- 168 Manfréd Weisz was the wealthiest and most influential industrialist of Hungary, the founder and owner of the Weisz Manfréd Művek (Weisz Manfréd Works) of Csepel.
- 169 KA MS/PK I-4/9 2689 ex 1909
- 170 During the Hungarian Coalition Government (1906-1909) Ferenc Kossuth, the son of Lajos Kossuth was the Commerce minister, but the real head of the Ministry was undersecretary of state József Sztérenyi because Kossuth was constantly ill.
- 171 KA MS/PK I-4/9 2754 ex 1909
- 172 KA MS/PK I-4/9 2931 ex 1909
- 173 KA MS/PK XV-7/8 120 ex 1909
- 174 KA MS/PK I-4/9 2926 ex 1909

- 175 KA MS/PK I-4/9 3638 ex 1909
- 176 KA MS/PK I-4/9 3639 ex 1909
- 177 KA MS/PK I-4/9 2689 ex 1909
- 178 KA MS/PK I-4/9 2926 ex 1909
- 179 KA MS/PK I-4/9 3896 ex 1909
- 180 KA MS/PK I-4/9 4550 ex 1909
- 181 KA MS/PK I-4/9 4661 ex 1909
- 182 KA MS/PK I-4/9 4661 ex 1909
- 183 KA MS/PK I-4/9 4328 ex 1909
- 184 KA MS/PK I-4/6 4615 ex 1909
- 185 KA MS/PK I-4/9 4328 ex 1909
- 186 KA MS/PK I-4/6 627 ex 1910
- 187 Állami költségvetés a Magyar Szent Korona országai részére az 1911-évre, Budapest, 1910, Kereskedelemügyi Minisztérium pp. 134-135.
- 188 KA MS/PK I-4/6 3090 ex 1910
- 189 Ramoser pp. 120-122.
- 190 Ramoser pp. 124-125.
- 191 Ramoser p. 132.
- 192 KA MS/PK XV-7/5 960 ex 1911
- 193 Közösügyi Bizottság 1910/II napló p. 79.
- 194 Közösügyi Bizottság 1910/II napló pp. 80-81.
- 195 Közösügyi Bizottság 1910/II napló pp. 120-125.
- 196 StPD XLV/X. 1911 pp. 496-521. p. 552.
- 197 Ramoser pp. 78-79.
- 198 Ramoser p. 81.
- 199 KA MS/PK I-4/9 4550 ex 1909
- 200 KA MS/PK I-4/9 4433 ex 1909
- 201 Ramoser p. 84.
- 202 KA MS/II GG 13/22 ex 1909 The per ton price of the KC armour was 2150 Kronen and that of the K armour was 1400 Kronen. Additional charge for bent armour plates was 300 Kronen per ton.
- 203 Ramoser p. 85.
- 204 KA MS/PK I-4/7 127, 409 ex 1911
- 205 KA MS/PK I-4/7 729 ex 1911
- 206 Ramoser pp. 167-168.
- 207 Ramoser pp. 168-169., KA MS/PK I-4/4 1032 ex 1912
- 208 Ramoser p. 165., Neudeck-Schulz-Blochmann: Der Moderne Schiffbau. Berlin, Leipzig 1912, Appendix
- 209 MMKMA Mladiáta-collection carton 42 "Kollaudierung S. M. S. VIRIBUS UNITIS". The trials were the followings: machinery trial in the port, 6 hours first sea trial, 8 hours trial with increasing than decreasing power, 30 hours trial with 5000 SHP, 30 hours trial with 17,000 SHP, 4 hours trial on an 8 nautical mile test course with 20,000 SHP, 2 hours trial on an 8 nautical mile test course with full power, 8 hours manoeuvre trial and 4 hours trial of the auxiliary oil firing. All trials had to be executed with 900 tons of coal and half provisions.
- 210 MMKMA Mladiáta-collection carton 14 "24,500 T Schlachtschiff Projekt"
- 211 MMKMA Mladiáta-collection carton 42 "Kollaudierung S. M. S. VIRIBUS UNITIS"
- 212 MMKMA Mladiáta-collection carton 14 "24,500 T Schlachtschiff Projekt"
- 213 KA MS/II. GG 47D/2 81 ex 1916
- 214 KA MS/II. GG 47C/6 10 ex 1912, MMKMA Mladiáta-collection carton 42 "Kollaudierung S. M. S. VIRIBUS UNITIS"
- 215 KA MS/II. GG 47D/2 81 ex 1916
- 216 MMKMA Mladiáta-collection carton 42 "Kollaudierung S. M. S. VIRIBUS UNITIS"
- 217 Ramoser p. 168.
- 218 MMKMA Mladiáta-collection carton 42 "Kollaudierung S. M. S. VIRIBUS UNITIS"
- 219 MMKMA Mladiáta-collection carton 42 "Kollaudierung S. M. S. VIRIBUS UNITIS"
- 220 MMKMA Mladiáta-collection carton 42 "Kollaudierung S. M. S. TEGETTHOFF"
- 221 During the trials the ship was commanded by Linienschiffskapitän Anton Alexander Hansa.
- 222 Ramoser p. 309.
- 223 On these differences see Prasky pp. 165-170.
- 224 Prasky p. 42.
- 225 Prasky p. 171.
- 226 KA MS/II. GG 47D/2 19, 81 ex 1916
- 227 Insufficient ventilation was a general problem maybe on every battleship and battlecruiser of the period. See the Austro-Hungarian report on the German experiences of the Battle of Skagerrak (Jutland) MMKMA Mladiáta-collection carton 31 "Skagerrak-Bericht" and Krámlí Mihály: A Skagerrak-misszió. In: Hadtörténelmi Közlemények 2016/4 p. 1050.
- 228 KA MS/II. GG 47D/2 81 ex 1916
- 229 KA MS/II. GG 47D/2 81 ex 1916
- 230 KA MS/II. GG 47D/2 81 ex 1916 After the first salvo the turret rangefinders lost their calibration.

- 231 KA MS/II. GG 47D/2 81 ex 1916
- 232 Linienschiffskapitän Edmund Grassberger who was the commander of the *Viribus Unitis* in May 1915 in his report on the Bombardement of Ancona did not mention this problem. *Viribus Unitis* opened fire at 4:38 a.m. and ceased fire at 5 a.m., when all the other battleships ceased fire. The commander of the First Battleship Squadron Vizeadmiral Maximilian Njegovan also did not mention this in his report, while he mentioned a less important problem with the center gun of the Turret II of the *Tegetthoff*. HL I. VH carton 4502
- 233 KA Marine Plansammlung "Turmventillation"
- 234 KA MS/II. GG 47D/2 61 ex 1916
- 235 KA MS/II. GG 47D/2 81 ex 1916
- 236 KA MS/II. GG 47D/2 81 ex 1916
- 237 KA MS/II. GG 47D/2 81 ex 1916
- 238 KA MS/II. GG 47D/2 81 ex 1916
- 239 KA MS/II. GG 47D/2 81 ex 1916
- 240 KA MS/II. GG 47D/2 81 ex 1916
- 241 Schiel p. 161.
- 242 Sources vary on the precise time of the launch between 10:45 and 11 a.m. The telegram sent from the shipyard to the Marinesektion in Vienna indicates 10:50 a.m.
- 243 KA MS/PK XV-7/6 1582 ex 1904. KA MS/PK XV-7/859 ex 1906
- 244 Közösügyi Bizottság, napló 1893 p. 37. Originally, in 1867 the Hungarian Quota was 30% and the Austrian Quota was 70%. Around the turn of the century the Hungarian Quota began to grow. Finally, the Hungarian Quota reached 36.4% in 1906.
- 245 Közösügyi Bizottság, irományok 1897 p. 29.
- 246 Közösügyi Bizottság, irományok 1898 pp. 50-51.
- 247 KA MS/PK XV-7/3 2464 ex 1898
- 248 KA MS/PK XV-7/2 502 ex 1902. In 1900 only 13.5 percent of the naval budget spent at home fell to Hungary.
- 249 KA MS/PK X-5/3 2124 ex 1900 (the resolution of the Hungarian government of 7 February 1900). KA MS/PK XV-7/6 3104 ex 1900 (the new resolution of the Hungarian delegation of May 1900).
- 250 KA MS/PK XV-7/6 2227 ex 1906.
- 251 KA MS/PK XV-7/6 341 ex 1904
- 252 KA MS/PK XV-7/6 1582 ex 1904
- 253 KA MS/PK XV-7/1 859 ex 1906
- 254 KA MS/PK I-4/6 2872 ex 1906
- 255 KA MS/PK I-4/6 2546 ex 1905, KA MS/II. GG 47C/6 12715 ex 1906
- 256 MMKMA Mladiáta-collection carton 12 LXXXIII/69, 70
- 257 StPD XLI/II 1906 p. 1178.
- 258 KA MS/II GG 47C/6 12253 ex 1907
- 259 KA MS/PK I/4-6 923 ex 1909
- 260 MMKMA Petneházy-collection 36 t
- 261 KA MS/PK XV-7/5 2103, 2361 ex 1908
- 262 KA MS/II GG 47C/17 10802 ex 1910. The British Laird offered a price of 718,000 Kronen and the Austrian CNT 1.004 million Kronen.
- 263 The hulls and the boilers were built in Fiume, but the steam engines were built in Budapest.
- 264 MNL OL Z 429 carton 18 131
- 265 MMKMA Petneházy-collection carton 10. The licence fee in case of battleships was 9 Kronen per shaft horsepower.
- 266 KA MS/PK I-4/6 5170 ex 1910
- 267 The total worth of the orders including the battleship from the Danubius was 62.1 million Kronen. The Navy ordered from the STT hulls and machineries worth of 69.1 million Kronen and from the CNT worth of 9.8 million Kronen. This meant that 44 percent of the hull and machinery orders of the 1911 programme went to the Hungarian industry.
- 268 Szekeres József: Az újpesti hajóépítés története I-II. In: Tanulmányok Budapest múltjából XIV-XV, 1961-1962 p. 525.
- 269 Koudelka pp. 113-114
- 270 KA MS/PK I-4/9 2935 ex 1909
- 271 KA MS/PK I-4/7 729 ex 1911
- 272 KA MS/II. GG 47C/6 2026 ex 1912
- 273 KA MS/II. GG 47C/6 3843 ex 1912
- 274 KA MS/II GG 47C/6 15009
- 275 Ramoser p. 249.
- 276 MMKMA Mladiáta-collection carton 13 "Berechnung von Wassereinbrüchen auf S. M. S. Szent István"
- 277 Stodola is an iterative method of calculating the fundamental transverse frequency for steam-turbine rotors.
- 278 MMKMA Mladiáta-collection carton 36 LVI/5
- 279 KA MS/II GG 47C/6 37 ex 1912
- 280 KA MS/PK XI-4/9 3378 ex 1911
- 281 KA MS/PK XI-4/9 1967 ex 1911

- 282 HL VII. 97. 99/A Franz von Holub to Pál Lázár
- 283 Krámlí 2010 and Dombrády Lóránt–Germuska Pál–Kovács Géza–Kovács Vilmos: *A magyar hadiipar története*, Budapest, 2016 pp. 69-73.
- 284 KA MS/PK I-4/6 488 ex 1911
- 285 KA MS/PK I-4/6 782 ex 1911
- 286 KA MS/PK I-4/6 5432 ex 1912
- 287 KA MS/II. GG 47C/5 142 ex 1913
- 288 KA MS/PK I-4/4 565 ex 1908
- 289 Halpern 1998 p. 143.
- 290 Ramoser 1998 p. 224.
- 291 KA MS/PK I-4/12 4542 ex 1913
- 292 Louis A. Gebhardt Jr.: *The Development of the Austro-Hungarian Navy, 1897-1914, A Study in the Operation of Dualism*. Ph. D. dissertation, Rutgers University, 1965 p. 251.
- 293 Ramoser p. 226.
- 294 KA MS/PK I-11/31 525 ex 1914
- 295 MMKMA “Fiumei m. kir. Állami Tengerészeti Akadémia jegyzői naplója 1895-1918”
- 296 A “Szent István” csatahajó In: *A Tenger 1914/I-II*. “I follow with my felicitations the career of this ship which demonstrates the capacity of the Hungarian naval industry and I hope this mighty unit of our fleet which bears the name of the holy Hungarian king will contribute to the preservation of the authority and glory of the fleet.”
- 297 KA MS/PK I-4/6 1088 ex 1914
- 298 KA MS/PK I-4/6 5700 ex 1913
- 299 KA MS/II GG 47C/5 71 ex 1914
- 300 KA MS/II GG 47D/2 16 ex 1916
- 301 KA MS/II GG 16D/21 17 ex 1914
- 302 KA MS/II GG 47C/5 47 ex 1914
- 303 KA MS/II GG 47C/1 30 ex 1915
- 304 KA MS/II GG 47D/1 31 ex 1915
- 305 KA MS/II GG 47C/5 89 ex 1914
- 306 KA MS/II GG 47D/1 73 ex 1915
- 307 KA MS/II GG 47D/1 122 ex 1915, KA MS/II GG 11812/4 ex 1915
- 308 The protocol of the full power trial (as of the other trials) was a printed form of several pages with dotted lines for the data. In the case of the *Szent István* this form was filled out only partially, the dotted line for the maximum speed was not filled out. While the maximum speed is missing, we know from the same protocol the maximum power of her machinery, measured by torsionmeters on the shafts, or the temperature in the boiler rooms, which was a cozy 28 degrees Celsius. The speed trials of the Austro-Hungarian warships usually were conducted on an eight mile test course in the Fasana Canal. Speed was determined by measuring the times between passing two well known shore objects with stopwatch. The final trials speed was determined by averaging all of the measured speeds.
- 309 KA MS/II GG 47C/6 10 ex 1912
- 310 KA MS/II GG 47D/2 44 ex 1916
- 311 MNL OL Z 429 carton 18 130
- 312 KA MS/II GG 47D/2 16 ex 1916
- 313 KA MS/II. GG 47D/2 46 ex 1916
- 314 KA MS/II. GG 47D/2 10 ex 1916
- 315 KA MS/II. GG 47D/2 11 ex 1916
- 316 KA MS/II. GG 47D/2 5 ex 1916
- 317 MNL OL Z 429 carton 18 130
- 318 KA MS/II. GG 47D/2 40 ex 1916
- 319 KA MS/II. GG 47D/2 41 ex 1916
- 320 KA MS/II. GG 47D/2 78 ex 1916
- 321 KA MS/II. GG 47D/2 44 ex 1916
- 322 KA MS/II. GG 47D/2 78, 82 ex 1916
- 323 KA MS/II GG 47D/2 16 ex 1916
- 324 KA MS/II GG 47D/2 16 ex 1916
- 325 KA MS/II GG 47D/2 81 ex 1916
- 326 KA MS/II GG 47D/2 46 ex 1916
- 327 KA MS/II GG 47D/2 81 ex 1916
- 328 KA MS/II GG 47D/2 81 ex 1916
- 329 KA MS/II GG 47D/2 81 ex 1916
- 330 KA MS/II GG 47D/2 81 ex 1916
- 331 KA MS/II GG 47D/2 81 ex 1916 Some of his proposals for the future battleships were far-seeing, diesel generators for supplying gun turrets and emergency use and a version of “all or nothing” armor protection are something that was far in the future for most navies. (Tony DiGiulian’s note)
- 332 MMKMA Mladiáta-collection carton 1 “Gewichtsrechnung S. M. S. VIRIBUS UNITIS”
- 333 The so called “caliber race” started in 1909. Because the armor penetration capability of the 30.5 cm gun proved to be insufficient against the newer, better protected battleships, the Royal Navy introduced the 34.3 cm gun in 1909, appeared first on the ships of the *Orion* class. The US and the Imperial Japanese Navy introduced the 35.6 cm

- caliber two years later. The Royal Navy introduced an even larger caliber, 38.1 cm in 1912. The German Navy introduced the 38 cm gun in 1913. Of the Mediterranean Powers, only the French succeeded to introduce a new caliber, 34 cm. The plans of the other sea powers to introduce a caliber larger than 30.5 cm, failed. The 1922 Washington Treaty put an end to the caliber race.
- 334 KA MS/PK I-4/12 1183 ex 1912 The Škoda elaborated two variants: a similar to the contemporary British system, and a more complicated.
- 335 See Tibor Balla: *The Activities of the International ‘Scutari Detachment’ in 1913-1914*. In: Csaplár-Degovics, Krisztián (Edited by): “These were hard times for Skanderbeg, but he had an ally, the Hungarian Hunyadi”. *Episodes in Albanian-Hungarian Historical Contacts*. Budapest, 2019 (Balla 2019); Halpern 1998 pp. 101-108.
- 336 Franz Pitzinger (1858-1933) was the de facto successor of Siegfried Popper. In November 1910 he was promoted to Obere Schiffbauingenieur. In November 1914 he was promoted to Generalshiffbauingenieur, a rank which was originally created to Popper.
- 337 KA MS/II GG 47C613 1 ex 1911
- 338 KA MS/PK I-4/12 890 ex 1912 The projectile of the 34.5 cm gun weighed 650 kg and the 35.5 cm’s 700 kg. The German 35.5 cm Krupp gun’s projectile was much lighter at 610 kg.
- 339 KA MS/PK I-4/12 890 ex 1912
- 340 KA MS/PK I-4/12 1439 ex 1912 The Škoda made two series of designs which differed in the technical particulars of the any-angle loading. Due to the any-angle loading these turrets were overly large, heavy and poorly protected compared to their weight. The maximum elevation of the guns was 15 degrees.
- 341 KA MS/PK I-4/12 2388 ex 1912
- 342 One of the MTK’s 25,200 ton designs had more powerful machinery (36,000 SHP, 22.2 knots) than the other designs, this was enabled by the complete omission of the bow armour.
- 343 KA MS/PK I-4/12 2388 ex 1912
- 344 KA MS/PK I-4/12 2388 ex 1912
- 345 KA MS/PK I-4/12 1183 ex 1912
- 346 KA MS/PK I-4/12 2388 ex 1912
- 347 The lifting capacity of this dock was originally 22,000 tons, but after an improvement it was raised to 23,200 tons. The MTK’s January 1913 24,500 ton design’s displacement could be reduced to 23,107 tons unloading a part of the ammunition and fuel without losing the stability, but in the case of the 25,200 ton design this was impossible. The Navy planned to purchase a new, 40,000 ton floating dock from Germany for 8.4 million Kronen. In 1914 the Navy ordered this dock from the Blohm und Voss. Post-war, in 1919 Blohm und Voss sold the dock to a Dutch shipyard.
- 348 KA MS/PK I-4/12 2388 ex 1912
- 349 MMKMA Mladiáta-collection carton 20 “35 cm Z Gr. P Gr.”
- 350 The main reason behind this decision was the better protection: the simpler system needed a smaller barbette diameter (in the case of a triple turret 10.3 m instead of 11.2 m), which considerably reduced the badly protected (75 mm horizontal plate) area between the barbette and the gunhouse. KA MS/II GG 47C/6 ex 1914, the document was written in 1912
- 351 MMKMA Mladiáta-collection carton 20 Armor penetration curves of 35 cm APC and Einheitsgranate.
- 352 Erwin F. Sieche: *The 35 cm Guns of the “Improved Tegetthoff-class” Battleships (Sieche)*
- 353 Schiel p. 201.
- 354 Schiel p. 141.
- 355 MMKMA Mladiáta-collection “24,500 T Schlachtschiff”
- 356 MMKMA Mladiáta-collection carton 13 “24,500 T Schlachtschiff”
- 357 KA MS/PK I-4/11 1247 ex 1913
- 358 KA MS/PK I-4/11 1247 ex 1913
- 359 MMKM Mladiáta-collection carton 13 “24,500 T Schlachtschiff”
- 360 KA MS/PK I-4/11 1766 ex 1913
- 361 KA MS/PK I-4/11 500 ex 1913
- 362 KA MS/PK I-4/11 500 ex 1913
- 363 KA MS/PK I-4/11 500 ad 2 ex 1913
- 364 KA MS/PK I-4/9 493 ex 1914. Technical data: 29 600 ton design: 195.2×29 m, 45,000 HP/23 kn, 320 mm belt, 12×35 cm, 18×15 cm, 18×9 cm, 6×53 cm TL. 32,000 ton design: 197.7×29.5 m, 50,000 HP/23 kn,

- 320 mm belt, 13×35 cm, 18×15 cm, 18×9 cm, 6×53 cm TL.
- 365 KA MS/PK I-4/11 3724 ex 1913
- 366 KA MS/PK I-4/11 5256 ex 1913
- 367 KA MS/PK I-4/11 6078 ex 1913
- 368 KA MS/PK I-4/9 634 ex 1914
- 369 KA MS/PK I-4/9 670 ex 1914
- 370 This arrangement was accepted by the Navy because the German Navy also accepted similar designs.
- 371 KA MS/PK I-4/9 634 ex 1914
- 372 KA MS/PK I-4/9 634 ex 1914
- 373 KA MS/II GG 47 C/6 ex 1913
- 374 MMKMA Mladiáta-collection carton 13 “24,500 T Schlachtschiff”
- 375 KA MS/PK I-4/9 634 ex 1914
- 376 The Imperial German Navy was the first sea power which executed underwater explosion tests from 1906 on 1/1 scale sections of their dreadnought designs.
- 377 In the estate of János Mladiáta it can be found a part of the documentation of the test. MMKMA Mladiáta-collection carton 25
- 378 MMKMA Mladiáta-collection carton 25 “Projekt enies Sprengobjektes”
- 379 Schiel pp. 176-178.
- 380 MMKMA Mladiáta-collection carton 25 “Projekt eines Sprengobjektes”
- 381 MMKMA Mladiáta-collection carton 25 “Kommissionprotokoll”
- 382 MMKMA Mladiáta-collection carton 25 “Kommissionprotokoll”
- 383 MMKMA Mladiáta-collection carton 27 “Caisson Versuche”
- 384 MMKMA Mladiáta-collection carton 13 “24,500 T Schlachtschiff”
- 385 MMKMA Mladiáta-collection carton 13 “24,500 T Schlachtschiff”
- 386 KA MS/PK I-4/11 3724 ex 1913
- 387 MMKMA Mladiáta-collection carton 13 “24,500 T Schlachtschiff”
- 388 KA MS/PK I-4/11 6078 ex 1913 The weight of the foremast was 13 tons and the weight of the small mainmast was 1 ton.
- 389 MMKMA Mladiáta-collection carton 13 “24,500 T Schlachtschiff” The center of gravity of the *Viribus Unitis* was above the waterline by 1,789 mm and her metacentric height was 1,101 mm. The center of gravity of the first version of the 24,500 ton MTK design
- was above the waterline by 1,289 mm and her metacentric height was 1,886 mm.
- 390 MMKMA Mladiáta-collection carton 13 “24,500 T Schlachtschiff”
- 391 MMKMA Mladiáta-collection carton 13 “24,500 T Schlachtschiff”
- 392 In February 1914, the 4th Department of the II Geschäftsgruppe suggested examining the possibility of introducing geared turbines, either mechanical or hydraulic (Föttinger). KA MS/PK I-4/9 634 ex 1914
- 393 Halpern 1998 p. 118.
- 394 Halpern 1998 p. 98.
- 395 Halpern 1998 p. 100.
- 396 Halpern 1998 p. 74.
- 397 KA MS/PK I-4/11 1096 ex 1913
- 398 KA MS/PK I-4/11 2295 ex 1913
- 399 KA MS/PK I-4/11 2295 ex 1913
- 400 Teleszky was often called the “Marble Man,” who sat at the table quietly until the end of the debate and then said only one word: No.
- 401 KA MS/PK I-4/11 2295 ex 1913
- 402 Halpern 1998 p. 104.
- 403 KA MS/PK I-4/11 2295 ex 1913
- 404 The Szabadelvű Párt (Liberal Party) was the governing party in Hungary from 1875 to 1904. After the opposition parties won the election of 1904, Count István Tisza organised on the ruins of the Liberal Party a new party, the Nemzeti Munkapárt (National Party of Work), which was the governing party between 1911 and 1918.
- 405 KA MS/PK I-4/11 2295 ex 1913
- 406 KA MS/PK I-4/11 2295 ex 1913
- 407 See Halpern 1998 pp. 85-90, and Balla 2019 pp. 147-150
- 408 He was seriously ill he had a tumor in his stomach. After the operation it turned out that the tumor was benign.
- 409 KA MS/PK I-4/11 2295 ex 1913
- 410 “Panamist” is a reference to the French corruption scandals of 1892 surrounding the failed Panama Canal project.
- 411 KA MS/PK XV-7/7 1035 ex 1914
- 412 Halpern 1998 p. 118.
- 413 KA MS/PK I-4/11 2536, 3724 ex 1913
- 414 KA MS/PK XI-4/9 582 ex 1913
- 415 KA MS/PK XI-4/9 509 ex 1914
- 416 KA MS/PK XV-7/7 1035 ex 1914
- 417 KA MS/PK XV-7/7 1035 ex 1914

- 418 Sondhaus p. 229.
- 419 This does not mean that the contracts had not been concluded. There are several reasons why contracts, if they existed, have disappeared from the file.
- 420 See Sieche, Sieche states that the Navy ordered these guns on 24 July 1914. The Škoda Works and the Witkowitz Ironworks as early as in March 1914 urged the Navy to order the gun turrets for the first unit of the class. KA MS/PK I-4/9 1138, 1327 ex 1914. In the official file which deals with the 35 cm guns in 1914 (KA MS/II GG 47C/6 ex 1914) there is no sign of an official contract, but the Navy had to order these guns because two or three actually were manufactured. There are only reports on that the Škoda gathered material worth of 6 million Kronen for the 35 cm guns.
- 421 KA MS/PK I-4/9 2958 ex 1914
- 422 KA MS/PK I-4/9 634 ex 1914
- 423 KA MS/II GG 47C/6 ex 1914
- 424 KA MS/PK XV-7/7 4935 ex 1914. In response to the questions of the Hungarian Finance Ministry the common Ministry of War presented the necessary restrictions in the fleet program, among them the cancellation of the building of the battleships VIII-XI.
- 425 M. Christian Ortner: *Die österreichisch-ungarische Artillerie 1867-1918* Wien, 2007 (Ortner) pp. 544-545.
- 426 Ortner p. 545.
- 427 See Erwin F. Sieche: *Großkampfschiffs-Projekte des MTK aus der Zeit des Ersten Weltkrieges* In: *Marine-Gestern, Heute* issue 8 (1981) No. 4
- 428 Although these are just speculations in this context, these names had some grounding in truth. *Hunyadi* was proposed twice by the Navy in 1908 and in 1913, but both times it was rejected. However, the list of the possible Hungarian battleship names acceptable for the Habsburgs was rather short. In a document of 1908 *Laudon* was listed among the popular names for battleships. KA MS/PK I-4/4 565 ex 1908
- 429 For example, in 1913 Franz Ferdinand intended to give German names to all of the 250 ton torpedo boats under construction in the Hungarian Ganz and Co. Danubius Shipyard. To avoid the scandal the Navy decided that from 1 January 1914 all the torpedo boats, now in commission or under construction, would have numbers instead of names.
- 430 These estimates are based on theoretical calculations, the first by Taylor, and the second by Froude method. MMKMA Mladiáta-collection carton 13 “24,500 T Schlachtschiff”
- 431 Halpern 1998 pp. 84-85. Ripper retired from the Navy on 1 March 1913.
- 432 Balla 2019 pp. 147-150.
- 433 Balla 2019 p. 157.
- 434 Balla 2019 p. 156.
- 435 Halpern 1998 p. 119.
- 436 HL I. VH carton 4500 MS/OK Nr. 3174 ex 1914
- 437 Halpern 1971 pp. 275-276.
- 438 Sondhaus p. 261.
- 439 In July 1880 a committee chaired by Archduke Albrecht met in Vienna to decide on the future development of the Navy. The Archduke concluded that it was enough to maintain the Navy's strength instead of developing it. He advised to pursue a coastal defense strategy, and conduct a *Verteidigungskrieg im Kleinen* (defensive war in little) in a future war against Italy. Reiter pp. 68-70.
- 440 On the Austro-Hungarian side see: Krámlí 2016
- 441 Hans Hugo Sokol: *Österreich-Ungarns Seekrieg 1914-1918*. 2 vol. Wien, 1933 (Sokol) p. 131.
- 442 Sokol p. 135.
- 443 Merényi-Metzger Gábor: *A ZENTA cirkáló személyzete 1914. augusztus 16-án*. In: *Hadtörténelmi Közlemények* 2009/3
- 444 HL I. VH carton 4503 MS/OK Nr. 6375 ex 1914
- 445 The Austro-Hungarian Navy used Roman numerals for submarines until January 1915.
- 446 Paul G. Halpern: *The Naval War in the Mediterranean 1914-1918*. Annapolis, 1987 (Halpern 1987) pp. 85-86.
- 447 See Balla Tibor: *Szövetségesből háborús ellenfél. Olaszország 1915. májusi hadba lépésének katonapolitikai előzményei és körülményei* In: *Hadtörténelmi Közlemények* 2015/3
- 448 Sokol pp. 164-169. Erwin F. Sieche: *Die diplomatische Aktivitäten rund um das Haus-*

- Memorandum vom März 1915. Marine–Gestern, Heite 9 (1982)
- 449 Halpern 1987 pp. 102-104.
- 450 Buzzati's most famous novel, the "Deserto dei tartari" (The Tartar Steppe) tells the story of an officer, Giovanni Drogo, and his life spent guarding the Bastiani Fortress, an old, remote border fortress. He spends his career waiting for the war with the barbaric enemy beyond the desert, the Kingdom of the North. The Kingdom of the North is unmistakably the symbol of the Habsburg Empire.
- 451 Halpern 1998 p. 225.
- 452 Halpern 1998 pp. 226-227. There were hopes in Austria-Hungary and also in Germany in May 1915 that a quick and successful strike against Italy would make turn the Italian public against the war.
- 453 HL I. VH carton 4502 "Bericht des Generalkonsuls Peter von Moricz über dessen Wahrnehmungen in Ancona"
- 454 HL I. VH carton 4502 "S. M. S. Radetzky Res. Nr. 381 Gefechtsbericht"
- 455 HL I. VH carton 4502 "K. u. K. I. Geschwaderkommando Res. Nr. 680/m Gefechtsrelation über Aktion gegen Küste bei Ancona"
- 456 The price of a 30.5 cm HE projectile was 1,488 Kronen.
- 457 The Italians sent two airships against Austro-Hungarian ships, but one of them had to turn back due to engine problems. On 8 June 1915, the *Città di Ferrara* was shot by an Austro-Hungarian flying boat near the Island of Lussin
- 458 HL I. VH carton 4502 "K. u. K. I. Geschwaderkommando Res. Nr. 680/m Gefechtsrelation über Aktion gegen Küste bei Ancona," "S. M. S. Franz Ferdinand Res. Nr. 328," "S. M. S. Prinz Eugen Gefechtsbericht," "S. M. S. Viribus Unitis Res. Nr. 425," "S. M. S. Tegetthoff Res. Nr. 339/A"
- 459 Sifferlinger p. 136.
- 460 The projectile may have exploded because it lost its ballistic cap during the flight. The sudden increase of the breaking force acting on the projectile when the ballistic cap fell could have been enough to actuate the sensitive base fuze. Thanks to András Hatala for this explanation.
- 461 HL I. VH carton 4502 "S. M. S. Radetzky Res. Nr. 381 Gefechtsbericht"
- 462 HL I. VH carton 4502. "S. M. S. Zrínyi Res. Nr. 331 Gefechtsbericht." Lajos Győri, who served on the *Zrínyi* provides a colorful description of the encounter with the Italian airships in his book. Győri Lajos: A császári és királyi haditengerészet békében és háborúban. Debrecen, 1935
- 463 HL I. VH carton 4502 "S. M. S. Novara Res. Nr. 313"
- 464 HL I. VH carton 4502 MS/OK Nr. 3939/1915
- 465 HL I. VH carton 4502 "S. M. S. Viribus Unitis Res. Nr. 425."
- 466 HL I. VH carton 4502 "K. u. K. I. Geschwaderkommando Res. Nr. 680/m Gefechtsrelation über Aktion gegen Küste bei Ancona." "S. M. S. Tegetthoff Res. Nr. 339/A." At 5:06 a.m. the barrel of the central gun in gun turret No. II (fore superimposed) became loose in the slide due to a malfunction of the locking system. It was soon fixed and no damage was found.
- 467 It was discovered later that the explosion was the result of sabotage. Sokol p. 244.
- 468 Halpern 1987 p. 147.
- 469 Schifferlinger p. 142.
- 470 Krámlí Mihály: A császári és királyi haditengerészet és Magyarország. Pécs, 2004 p. 79. The Navy had a special boiler in Pola for examining different types of coal.
- 471 See Karl Fanta: Die österreichisch-ungarische Kriegsmarine im Ersten Weltkrieg: Eine kritische untersuchung der Logistik und ihres Zusammenhang mit der k. u. k. Flottenstrategie. Ph. D. thesis, Universität Wien, 1997. Low quality domestic coal was used on ships in harbor. Despite the economizing and importation from Germany, by 1918 the coal stocks were reduced to 170,000 tons.
- 472 Wagner pp. 105-107.
- 473 On the battle see: Paul G. Halpern: The Battle of the Otranto Straits. Bloomington 2004.
- 474 Halpern 1987 p. 447.
- 475 Sondhaus pp. 309-310.
- 476 See Hetés Tibor–Dezsényi Miklós: Flotafelkelés Bocche di Cattaroban. In: Hadtörténelmi Közlemények 1958/1-2 pp. 95-96. They quoted non-existing documents. On the popularity of this belief see: Turbucz Dávid: A Horthy kultusz 1919-1944. Budapest, 2016 pp. 9-11.

- 477 Sondhaus p. 324
- 478 Among the supporters of Horthy's appointment was Rudolf von Montecuccoli, Marinekommandant between 1904 and 1913 and Archduke Karl Stephan himself. Thanks for this information to Dávid Turbucz.
- 479 Wagner p. 113
- 480 Halpern 1987 pp. 434-441
- 481 Miklós Horthy: Memoires, London, 1956 (Horthy) pp. 103-104.
- 482 Owen Rutter: Regent of Hungary: The Authorized Life of Admiral Nicholas Horthy 1939 p. 57.
- 483 Erwin F. Sieche: S. M. S. Szent István: Hungaria's Only and Ill-fated Dreadnought. In: Warship International 1991/2 (Sieche 1991) p. 124.
- 484 On these theories see: Sieche 1991 pp. 131-136. and Balogh Tamás–Csepregi Oszkár: A Szent István csatahajó és a csatahajók rövid története Budapest 2002 (Balogh–Csepregi) pp. 108-117.
- 485 In Hungarian: A flotta első és utolsó kikutása (The First and Last Sortie of the Fleet) published in the volume Egon Erwin Kisch: Ciánkáli a vezérkarnak Budapest, 1987. Kisch states that Horthy called of the operation before the sinking of the *Szent István* and the battleship was torpedoed on the way back to Pola. He lies also when he states that the *Viribus Unitis* passed the sinking ship without attempting to rescue the survivors. In fact Horthy called off the operation when the news of the sinking of the *Szent István* reached him.
- 486 Karl Mohl: Vortrag über Untergang Szent István KA MA-SR-VARIA (Mohl); Bánsági Andor: A Szent István csatahajó elsüllyedése dokumentumok tükrében In: Hajózástörténeti Közlemények 3 (2008) 2. sz. www.kriegsmarine.hu/hk/ba00802f.html (Bánsági)
- 487 The report of the board of inquiry Bánsági. The board of inquiry was on the opinion that the times 10:15 and 10:25 p.m. reported by the battleships's commanders did not correspond to reality.
- 488 Seitz's report Bánsági
- 489 La beffa di Buccari (Buccari Mockery) was an attack of three Italian MAS boats on the port of Buccari on the night of 10/11 February 1918. This rather propagandistic raid was led by a "dream team" consisted of capitano di fregata Costanzo Ciano, capitano di corvetta Luigi Rizzo and the poet Gabriele D'Annunzio. They could reach their targets unnoticed and fired their torpedoes. The torpedoes scored no hits. The boats successfully escaped. Despite the lack of material success it was heavily publicized by D'Annunzio and the Buccari Mockery helped to raise the Italian morale. On the other side, the Italians largely overestimated the morale blow on Austria-Hungary.
- 490 Roger Branfil-Cook: Torpedo: The Complete History of the World's Most Revolutionary Naval Weapon. Barnsley, 2014 p. 186. The two torpedoes were manufactured for Italy in 1906 in the Whitehead factory in Fiume. The weight of their warheads was 150 kg.
- 491 Rizzo's report Bánsági
- 492 The report of the board of inquiry Bánsági
- 493 These are the true locations of the two hits based on the discoveries of the diving expeditions. See Balogh 2008
- 494 Pintér Ferenc: A volt Osztrák-Magyar Monarchia haditengerészetének S. M. S. Szent István csatahajó 1918. június 10-én történt elsüllyedésének története. Manuscript, quoted in Balogh–Csepregi p. 188.
- 495 Mohl
- 496 The report of the board of inquiry Bánsági
- 497 Mohl
- 498 The report of the board of inquiry Bánsági
- 499 Balogh 2008
- 500 The report of the board of inquiry Bánsági
- 501 It can be seen on the film footage of the sinking of the *Szent István* one of the projectiles splashing into the sea.
- 502 KA MS 4 Abt. 11196 ex 1917
- 503 Mohl
- 504 Report of Seitz and report of Pergler von Perglas Bánsági
- 505 The last moments of the battlecruiser *Hood* in 1941 were also filmed from the *Prinz Eugen* but the film is of poor quality.
- 506 Report of the board of inquiry Bánsági
- 507 Report of Pergler von Perglas Bánsági. Probably the number of the lightly woundeds was much higher but they were not listed officially among the woundeds.

- 508 Balogh–Csepregi p. 105. and Pintér quoted in Balogh–Csepregi pp. 190-191.
- 509 Koudelka p. 282.
- 510 KA MKSM carton 1380 66-5/9 ex 1918
- 511 KA MKSM carton 1380 66-5/9-3 ex 1918
- 512 Report of the board of inquiry Bánsági. The original report is not found in the Kriegsar-
chiv Vienna, but Luigi Rizzo published it in
his book. Rizzo’s book is the source of the lat-
ter translations.
- 513 Winkler, Dieter–Sieche, Erwin–Blasi, Wal-
ter: Seiner Majestät Schlachtschiff Szent Ist-
ván. Der ungarische Dreadnought im Spie-
gel von Zeitzeugenberichten (Winkler–
Sieche–Blasi)
- 514 MMKMA Mladiáta-collection carton 27
“Caisson Versuhe”
- 515 Winkler–Sieche–Blasi
- 516 Report of the board of inquiry Bánsági
- 517 Report of the board of inquiry Bánsági
- 518 Report of the board of inquiry Bánsági. The
report quotes here almost literally the opinion
of Grassberger.
- 519 Report of the board of inquiry Bánsági
- 520 KA MKSM carton 1380 66-5/9-5 ex 1918
- 521 The 2008 documentary “Tod im Morgen-
grauen–Der Untergang der Szent István”
partly was based on Dueller’s memoirs.
- 522 Balogh–Csepregi pp. 186-202.
- 523 Balogh–Csepregi p. 195.
- 524 In May 1918, a plan of seizure of the torpe-
do boat 80 by a group of her crew was re-
vealed. After a short trial the two ringleaders,
a Croat and a Czech, were executed. Horthy
remembered this case in his report as an im-
portant turning point in restoring the order
and discipline after the Cattaro mutiny.
- 525 HL I VH carton 4504 K. u. k. A. O. K. Op.
Nr. 146649
- 526 Sondhaus pp. 350-352
- 527 HL I. VH carton 4504 Note of Emil Konek
from 1923. The text of the order was the fol-
lowing: „Die k. u. k. Flotte samt allen Ak-
zessorien ist auf Allerhöchsten Befehl, un-
ter ausdrücklichem Vorbehalt des Eigentums
Anteilsrechtes der nicht südslavischen Länder
der bisher bestandenen österreichisch-
ungarischen Monarchie morgen vormittag
bevollmächtigten Delegierten des Zagre-
ber Ausschusses des Nationalrates der Ser-
ben, Kroaten und Slovenen der Monarchie zu
übergeben.”
- 528 HL I. VH carton 4504 Note of Emil Konek
from 1923
- 529 Sondhaus p. 355.
- 530 Horthy p. 117.
- 531 Ramoser p. 441.
- 532 Prasky p. 236.
- 533 Polai matróz-forradalom története. Budapest,
1918 pp. 3-11.
- 534 The Italians were eager already in November
1918 to seek revenge for Lissa. On 4 Novem-
ber 1918 the Italians occupied the Island of
Lissa and later transported the Austrian Lissa
Memorial (statue of a dying lion) to Livorno.
- 535 HL I. VH carton 4504 PK/MS Nr. 6654 ex
1918
- 536 HL I. VH carton 4504 Deutschösterreichi-
sches Staatsamt für Ausseres Z. I 2726/2
- 537 Georg von Trapp: Bis zum letzten Flaggen-
schuss: die Erinnerungen eines österreichi-
schen U-Boots-Kommandanten. Salzburg,
1935. pp. 253-254
- 538 Sondhaus p. 359
- 539 Peter Jung: Umsturzjahr 1918–Ende und
Auflösung der k. u. k. Kriegsmarine. In:
Österreichische Militärgeschichte 1995/3 pp.
88-90.
- 540 KA MS/PK I-4/9 4661 ex 1909
- 541 KA MS/PK I-4/9 4234 ex 1909 Price of the
Škoda gun was 500,000 Kronen while the
Krupp gun’s 410,000 Kronen.
- 542 The projected Škoda 30.5 cm/50 gun weighed
61 metric tons and its muzzle velocity was 850
mps.
- 543 KA Marine Plansammlung “Schiffsturmla-
fette für drei 30,5 cm L/45 Geschütze”
- 544 Probably the main aim of this change was re-
ducing the burning temperature of the pro-
pellant in order to improve barrel life.
- 545 Ramoser p. 92
- 546 KA MS/II GG 47C/13 1
- 547 NA ONI Register No. 3882 R-2-b
- 548 Ortner pp. 544-545. It’s not entirely clear if
the 122 rounds included the proofing rounds
or not.
- 549 Horning: ring shrunk onto German and
Austro-Hungarian heavy guns to which the
piston rods of the recoil and run-out cylinders
were attached.

- 550 MNL OL Z402, carton 9 294 “Witkowitz Bergbau ügy Panzergranatokra vonatkozólag” 512 Kronen vs 471 Kronen
- 551 MNL OL Z402, carton 9 294 “Witkowitz Bergbau ügy Panzergranatokra vonatkozólag”
- 552 MNL OL Z402, carton 9 294 “Witkowitz Bergbau ügy Panzergranatokra vonatkozólag” The capped 30.5 cm HE projectile penetrated 180 mm KC at an impact speed of 540 mps.
- 553 This information was provided by Erwin F. Sieche. Test reports KA MS/II GG 4G/1 207, 217, 495, 587 ex 1914
- 554 MNL OL Z402 carton 9, 294 “Witkowitz Bergbau ügy Panzergranatokra vonatkozólag”
- 555 Prasky pp. 252-255.
- 556 Figurentafeln des k. u. k. Kriegsmarine eingeführten Geschößzündertypen, 1917
- 557 MMKMA Mladiáta collection carton 2 “Entwicklung Schieß und Artilleriewesens der k.u. k. Marine”
- 558 Ramoser p. 92.
- 559 MNL OL Z402, carton 9 294 “Witkowitz Bergbau ügy Panzergranatokra vonatkozólag”
- 560 MMKMA Mladiáta-collection carton 20 “Durchschlagvermögen 35 cm P. Gr. und 35 cm E. Gr.”
- 561 Information provided by András Hatala
- 562 Figurentafeln des k. u. k. Kriegsmarine eingeführten Geschößzündertypen, 1917
- 563 MMKMA Mladiáta-collection carton 2 “Entwicklung Schieß und Artilleriewesens der k.u. k. Marine”
- 564 MMKMA Mladiáta-collection carton 11 “Tabelle über die rauchlose Pulversorten b. Kriegs-Marine”
- 565 MMKMA Mladiáta-collection carton 11 “Tabelle über die rauchlose Pulversorten b. Kriegs-Marine” For reduced loads 700 mm long tubes were used.
- 566 Ramoser p. 527 and MMKMA Mladiáta-collection carton 2 “Entwicklung Schieß und Artilleriewesens der k.u. k. Marine”
- 567 Harmos Zoltán: Tüzérlövéstan Budapest, 1937 p. 35.
- 568 Some drawings suggest that this gun as land gun 35 cm/45 M16 used a larger brass case which contained all the propellant charge.
- 569 MMKMA Mladiáta-collection carton 13 “Patronenhülsen-Übernahmsinstruktion k. u. k. Kriegsmarine”
- 570 HL I. VH carton 4503 MS/OK Nr. 6375 ex 1914
- 571 All these data are from official documents. It must be noted that sometimes official documents are contradictory, for example one document states that the propellant weight for the 30.5 cm guns of the *Radetzky* class was 137 kg while other document states that its weight was 140 kg. Armor penetration was calculated using the De Marre formula at least in the case of the 30.5 cm and 24 cm guns of the *Radetzky* class. Range tables of the aforementioned guns went only to 15,000 m and 12,000 m, respectively. The estimated maximum range of these 30.5 cm guns was around 18,500 m, while of these 24 cm guns was 16,500 m. For the 35 cm gun no range table is available, their estimated range at 16° elevation (maximum elevation of the 35 cm turret designs) was around 21,000 m.
- 572 KA Marine Plansammlung “Schiffturnlafette für drei 30,5 cm L/45 Geschütze”; Jahrbuch der Schiffbautechnische Gesellschaft, Zwölfter Band. Berlin, 1911 p. 158. This device was called in a brochure “Universal-Transmission”. Its other name was “Williams-Janney” or “Waterbury” variable speed transmission.
- 573 Prasky p. 65. KA MS/II GG 47D/2 81 ex 1916 The report on the *Viribus Unitis* mentions the Umformers (Ward Leonard motor-generator units) in the turrets.
- 574 The October 1909 triple turret plans and description made by the Škoda show only four/five flats. On the 1/25 half-model of the *Viribus Unitis* there are five/six flats.
- 575 KA Marine Plansammlung “S. M. S. Prinz Eugen und VII Luftmotoren für Reserveantrieb der Munitionsaufzüge” Res 207 ex 1913
- 576 KA MS 4 Abt. 11196 ex 1917. The maximum train rate of the turret with this 20 HP engine was 45 degrees per minute.
- 577 Prasky p. 70.
- 578 KA Marine Plansammlung “S. M. S. Prinz Eugen und VII Luftmotoren für Reserveantrieb der Munitionsaufzüge” Res 207 ex 1913
- 579 KA Marine Plansammlung “Schiffturnlafette für drei 30,5 cm L/45 Geschütze”
- 580 After the Battle of Jutland German naval officers were very proud that the German fleet had had no *Totalverlust* (total loss) in the bat-

- tle. In the German naval jargon *Totalverlust* meant that a ship was destroyed within seconds due to an explosion. This was true for the modern *Lützow* but not for the older pre-dreadnought *Pommern*. HL I VH carton 4502 “Skagerrak-Bericht”.
- 581 HL I VH carton 4502 “Skagerrak-Bericht”; Krámlí 2016.
- 582 KA Marine Plansammlung “Projekt der Patronenförderung unter Wegfall der Patronendrescheibe in den Türmen der Schiff Type Tegetthoff”.
- 583 On the twin turrets the propellant gases were exhausted through an armored hood on the turret roof. For the triple turrets the same arrangement had been intended, but when the Navy ordered to install turret rangefinders on the turret roofs it had to redesign the system, or the gases would have exhausted directly into the rangefinder. Thus on triple turrets the propellant gases were exhausted between the turret stalk and the barbette.
- 584 Prasky p. 83. 1 officer, 1 electrician, 1 mechanic, 37 gunners and 50 seamen.
- 585 On the triple turrets each gun had two gun sights, one was for normal use while the other was coupled to the emergency hand elevation gear. When the guns were coupled together the right gun sight of the center gun was used. KA MS MTK Res Nr. 1139/III ex 1912.
- 586 During the gunnery trials it turned out that the full salvos with guns coupled together put an extreme stress on the weak hull structure, so it did not make much sense to build in the coupling. KA MS/II GG 47D/2 46 ex 1916.
- 587 KA MS/II GG 47D/2 81 ex 1916.
- 588 KA MS/II GG 47D/2 81 ex 1916.
- 589 KA Marine Plansammlung “Turmventillation”
- 590 Krámlí 2016 p. 1049.
- 591 KA MS/II GG 4D/4 2/21 ex 1911.
- 592 The weights of the triple turret designs were 885 and 897 tons while the twin turret designs weighed 611 and 621 tons. The thickness of the turret roof armor was only 60 mm. The greatest disadvantage of these designs was that between their barbetstes and gunhouses were overly large slots which were protected by relatively thin (75 mm) vertical armour. The greatest difference between the two versions was that the heavier turret design had separate projectile and cartridge hoists.
- 593 NA ONI Register No. 3884 R-2-b.
- 594 Prasky pp. 95-115. He published in his book some photographs of the fire control equipment of the *Tegetthoff* on display at the Technical Museum of Milan.
- 595 The report of February 1914 calls these indicators. NA ONI Register No. 3882 R-2-b.
- 596 MMKMA Mladiáta-collection carton 2 “Entwicklung Schieß und Artilleriewesens der k.u. k. Marine”.
- 597 The American report mentions a so called bearing apparatus consisting of two movable ruler stocks mounted on a stative. NA ONI Register No. 3882 R-2-b Maybe this is the device mentioned in the report of 1912.
- 598 In August 1909 the Navy ordered twelve rangefinders for the *Radetzky* class from the Austrian firm Karl Pecene. It turned out that the firm was not able fulfill the order, so the Hydrographisches Amt of the Navy in March and in August 1911 ordered the abovementioned rangefinders from the firm Barr & Stroud instead. In November 1911 the Navy made a comparative test with Pecene, Barr & Stroud and Zeiss rangefinders. On the basis of the test results the Hydrographisches Amt favoured the Barr & Stroud rangefinders, so the Navy ordered the rangefinders for the *Tegetthoff* class from this firm. Ramoser pp. 162-163.
- 599 NA ONI Register No. 3882 R-2-b.
- 600 NA ONI Register No. 3882 R-2-b.
- 601 KA Marine Plansammlung „Schiffsturmlafette für drei 30,5 cm Geschütze L/45 Zielempfänger mit Backswinkelzeiger”.
- 602 KA MS/PK I-4/9 670 ex 1914.
- 603 Prasky p. 113. The Argo Clocks were placed in the warehouse of the Schenker Company in Ostende. In 1915 the Schenker reported the Navy that the warehouse had been plundered a little before the German troops had arrived and the Argo Clocks had disappeared without a trace.
- 604 Prasky pp. 113-115.
- 605 Prasky pp. 111-113. NA ONI Register No. 3882 R-2-b.
- 606 NA ONI Register No. 3882 R-2-b. “Covered” is used in the report, a more common term would be “straddled.”

- 607 Ships were identified using different handbooks. Misidentification was not uncommon during the war, the most well known example in the Austro-Hungarian Navy was the misidentification of the approaching British cruisers during the initial phase of the Battle of the Otranto Straits on 15 May 1917.
- 608 Maybe this is a typing error, 16,000 m is more realistic. The maximum range of the 30.5 cm guns was around 19,000 m, while the range dials of the gun sights were graduated to 15 degrees. KA MS MTK Res Nr. 1139/III ex 1912. The initial range on the gunnery trial of the *Szent István* was 15,200 m which was soon reduced to 10,000 m. KA MS/II GG 47D/2 46 ex 1916. The short rangefinders of these battleships were inaccurate at ranges over 10,000 m.
- 609 NA ONI Register No. 3882 R-2-b.
- 610 KA MS/II GG 47D/2 46 ex 1916.
- 611 Attila József: "And so I've found my native country,/that soil the gravedigger will frame,/where they who write the words above me/do not for once misspell my name. This black collection-box receives me/(for no one needs me any more),/this Iron Six was worth twenty,/this coin left over from the war." Translated by Frederick Turner and Zsuzsanna Ozsváth.
- 612 The only active-duty officer whom was ever given this rank was Anton Haus (1916). The other Großadmirals were the members of the Habsburg and the Hohenzollern families.
- 613 This rank was given only to reserve officers. Professional officers were promoted after their successful exam to Fregattenleutnant.

Bibliography

- 3 maj. Složena organizacija udruženog rada brodograđevne industrije Rijeka. Rijeka, 1984.
- Aichelburg, Wladimir–Baumgartner, Lothar: Die „Tegetthoff“-Klasse: Österreich-Ungarns grösste Schlachtschiffe. München, 1981.
- Balla, Tibor: A militarista birodalom mítosza. Az osztrák-magyar haderő az első világháború előestéjén. Hadtörténelmi Közlemények 2014/3
- Balla, Tibor: Szövetségesből háborús ellenfél. Olaszország 1915. májusi hadba lépésének katonapolitikai előzményei és körülményei Hadtörténelmi Közlemények 2015/3
- Balla, Tibor: The Activities of the International "Scutari Detachment" in 1913-1914. In: Csaplár-Degovics, Krisztián (Edited by): "These were hard times for Skanderbeg, but he had an ally, the Hungarian Hunyadi". Episodes in Albanian-Hungarian Historical Contacts. Budapest, 2019.
- Balogh Tamás: Jelentés a „Szent István” csatahajónál 2008. szeptember 30. és október 5. között lefolyt expedíció eredményeiről. Manuscript, 2008.
- Balogh Tamás–Csepregi Oszkár: A Szent István csatahajó és a csatahajók rövid története Budapest, 2002.
- Bánsági Andor: A SZENT ISTVÁN csatahajó elsüllyedése dokumentumok tükrében. Hajózástörténelmi Közlemények 2008/3 www.kriegsmarine.hu/hk/ba00802f.html
- Baratelli, Franco: La marina militare italiana nella vita nazionale 1860-1914. Mursia, 1983.
- Baumgartner, Lothar–Pawlik, Georg–Sieche, Erwin F.: Die „Radetzky“-Klasse. Graz, 1984.
- Branfil-Cook, Roger: Torpedo: The Complete History of the World's Most Revolutionary Naval Weapon. Barnsley, 2014.
- Denn Österreich Lag einst am Meer. Das leben von Admirals Alfred von Koudelka. Graz, 1987.
- Dombrády Lóránt–Germuska Pál–Kovács Géza–Kovács Vilmos: A magyar hadiipar története, Budapest, 2016.
- Fanta, Karl: Die österreichisch-ungarische Kriegsmarine im Ersten Weltkrieg: Eine kritische untersuchung der Logistik und ihres Zusammenhang mit der k. u. k. Flottenstrategie. Ph. D. thesis, Universität Wien, 1997.
- Foerster, Wolfgang: Die deutsch-italianische Militärkonvention. In: Die Kriegsschuldfrage Vol. 5 (1927) Issue 5
- Friedman, Norman: Naval Weapons of World War One. Annapolis, 2011.
- Gebhardt, Louis A. Jr.: The Development of the Austro-Hungarian Navy, 1897-1914, A Study in the Operation of Dualism. Ph. D. dissertation, Rutgers University, 1965.

- Giorgerini, Giorgio–Nani, Augusto: *Le navi di linea italiane 1861-1961*. Roma, 1962.
- Gonda Béla: *Haditengerészetünk és a magyarság*
In: *A Tenger 1913/9*
- Gonda Béla: *Emlékezés Haus vezértengernagyra*
In: *A Tenger 1931/5-6*
- Greger, René: *Austro-Hungarian Warships of World War I*. London, 1976.
- Greger, René: *Who Was Responsible for the Faults in the Tegetthoff Class*. In: *Warship 1980/1*
- Grieffmer, Axel: *Linienfahrzeuge der Kaiserlichen Marine 1906-1918*. Bonn, 1999.
- Győri Lajos: *A császári és királyi haditengerészet békében és háborúban*. Debrecen, 1935.
- Halpern, Paul G.: *The Mediterranean Naval Situation*. Cambridge, Massachusetts, 1971.
- Halpern, Paul G.: *The Naval War in the Mediterranean 1914-1918*. Annapolis, 1987.
- Halpern, Paul G.: *Anton Haus. Österreich-Ungarns Großadmiral*. Graz, 1998.
- Halpern, Paul G.: *The Battle of the Otranto Straits*. Bloomington 2004.
- Harmos Zoltán: *Tüzérlövészet Budapest, 1937*.
- Hetés Tibor–Dezsényi Miklós: *Flottafelkelés Bocche di Cattaroban*. In: *Hadtörténelmi Közlemények 1958/1-2*
- Horthy, Miklós: *Memoirs*, London, 1956.
- Höbelt, Lothar: *Die Marine*. In: *Die Habsburgermonarchie. 5 k.: Die bewaffnete Macht*. Wien, 1987-
- Jahrbuch der Schiffbautechnische Gesellschaft, Zwölfter Band*. Berlin, 1911.
- Jung, Peter: *Umsturzjahr 1918 – Ende und Auflösung der k. u. k. Kriegsmarine*. Wien, 1995.
- Kisch, Egon Erwin: *Ciánkáli a vezérkarnak Budapest, 1987*.
- Koburger, Charles: *The Central Powers in the Adriatic, 1914-1918: War in a Narrow Sea Westport*, London, 2001.
- Krámlí Mihály: *A császári és királyi haditengerészet és Magyarország*. Pécs, 2004.
- Krámlí Mihály: *A Koudelka-misszió. Alfred von Koudelka fregattkapitány látogatása a berlini Birodalmi Tengerészeti Hivatalban és ennek dokumentumai, 1909. április 29-30. Hajózástörténelmi Közlemények (online) 2010/1*
www.kriegsmarine.hu/hk/km01001k.html
- Krámlí, Mihály: *Naval Shipbuilding in the Danubius Shipyard in Rijeka 1906-1915*. In: *Proceedings of the 3rd International Conference on the Preservation of the Industrial heritage in Rijeka* (ed. Miljenko Smokvina). Rijeka, 2010.
- Krámlí Mihály: *A Skagerrak-misszió. Osztrák-magyar haditengerészeti jelentés az 1916. május 31-június 1-jei skagerraki csata német tapasztalatairól*. *Hadtörténelmi Közlemények 2016/4*.
- Krenslehner, Erich: *Die k. u. k. Kriegsmarine als wirtschaftliche Faktor 1874-1914*. Ph. D. dissertation, Wien, 1972.
- McLaughlin, Stephen: *Russian & Soviet Battleships*. Annapolis, 2003.
- Merényi-Metzger Gábor: *A ZENTA cirkáló személynézet 1914. augusztus 16-án*. *Hadtörténelmi Közlemények 2009/3*
- Neudeck-Schulz-Blochmann: *Der Moderne Schiffbau*. Berlin, Leipzig 1912.
- Ortner, M. Christian: *Die österreichisch-ungarische Artillerie 1867-1918*. Wien, 2007.
- Polai matróz-forradalom története. Budapest, 1918.
- Prasky, Friedrich: *Die Tegetthoff-Klasse*, Wien, 2000.
- Ramoser, Christoph: *K. u. k. Schlachtschiffe in der Adria. Österreich-Ungarns Tegetthoff-Klasse*. Wien, 1998.
- Reiter, Leo: *Die Entwicklung der k. u. k. Flotte und die Delegationen des Reichsrates*. Ph. D. disszertáció, Wien, 1948.
- Rutter, Owen: *Regent of Hungary: The Authorized Life of Admiral Nicholas Horthy 1939*.
- Schiel, Rüdiger: *Die vergessene Partnerschaft. Kaiserliche Marine und k. u. k. Kriegsmarine 1871-1914*. Bochum, 2014.
- Schmidt-Brentano, Antonio: *Die österreichischen Admirale 1808-1924. I-III*. Osnabrück, Bissendorf 1997-2005.
- Sieche, Erwin F.: *Großkampfschiffs-Projekte des MTK aus der Zeit des Ersten Weltkrieges*. In: *Marine-Gestern, Heute 1981/4*
- Sieche, Erwin F.: *Die diplomatische Aktivitäten rund um das Haus-Memorandum vom März 1915*. In: *Marine-Gestern, Heute 9 (1982)*
- Sieche, Erwin F.: *Entwicklungsgeschichte der „Tegetthoff“-Klasse*. In: *Marine-Gestern, Heute 1984/4*
- Sieche, Erwin F.: *The 35 cm Guns of the “Improved Tegetthoff-class” Battleships*
- Sieche, Erwin F.: *S. M. S. Szent István: Hungaria's Only and Ill-fated Dreadnought*. In *Warship International 1991/2*

Kiadta/Publisher
Belvedere Meridionale, Szeged
www.belvedere.hu

Felelős kiadó/Executive publisher
dr. Jancsák Csaba

Műszaki szerkesztő/Typography & Layout
Domokos György

Nyomda/Print
Ronin Nyomdaipari, Kereskedelmi és Szolgáltató Bt., Budapest
www.roninnyomda.hu